



*French know-how - Französisches Know-how



Savoir-faire français*

collection 2023



*Quand je suis parmi vous, arbres de ces grands bois,
Dans tout ce qui m'entoure et me cache à la fois,
Dans votre solitude où je rentre en moi-même,
Je sens quelqu'un de grand qui m'écoute et qui m'aime !*

Victor Hugo, Les Contemplations, 1856

Sommaire

Contents

Inhalt

Rhodia Basics	28
Rhodia Classic	48
Rhodia Filing	60
Rhodiactive	64
Rhodiactive	64
Rhodiactive	64
Rhodiactive	64
Rhodia Writing	94
Rhodiarama	118
Rhodiarama home office	170
Rhodia Touch	194
Co-branding Rhodia x PAscribe	240
Collection Orange Botanique	244
PLV & merchandising / POP display advertising	252
Présentoirs / displays	258



Les reliures

Covers

Einbände



agrafé en-tête
head stapled
am Kopfende geheftet



agrafé côté
stapled on long side
an der langen Seite geheftet



reliure intégrale
wirebound
vollständige Bindung



reliure intégrale en-tête
wirebound at the top
vollständige Bindung am Kopfende



piqûre
staplebound
geklammert



piqûre textile
swen spine
Textilnaht



dos carré collé
glued spine
geleimte Rückseite



brochure cousue dos toilé
canvas-backed threadbound
genäht und mit Leinenrücken



rembordée rigide
hard cover
fester Einband



rembordée semi-rigide
soft cover
halbfester Einband



brochure cousue
threadbound
genäht



bloc encollé
glued at the top pad
geleimter Block



Les réglures

Rulings
Lineaturen

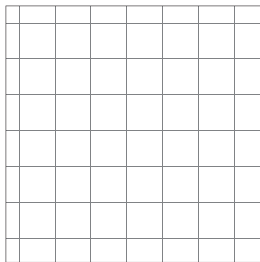

5 x 5
5 x 5 squared
5 x 5 kariert



ligné
lined
liniert



uni
blank
unbedruckt

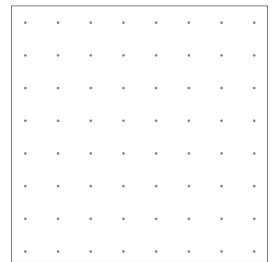

dot - 5 mm
dot grid - 5 mm
Punktraster - 5 mm

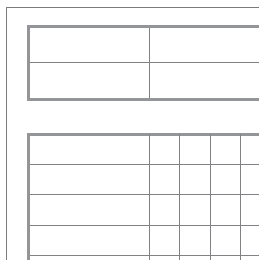

marge et cadre en-tête
margin and header box
Rand und Rahmen am Kopfende

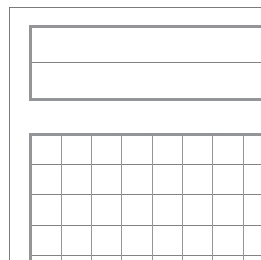

cadre en-tête
header box
Rahmen am Kopfende

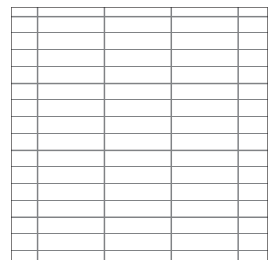

Seyès
French ruling
französische Lineatur



meeting : date, notes, action
meeting: date, notes, action
Besprechung: Datum, Notizen, Aktion

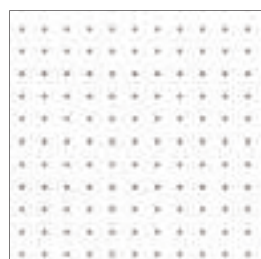

Cross

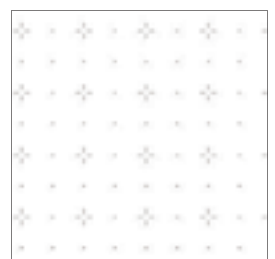

Cross 'n' Dot

28 basics

blocs agrafés
stapled notepads
geheftete Blöcke



blocs agrafés
couverture carte enduite orange, noir ou blanc
papier vélin surfin 80 g > disponibles aussi en coffrets
stapled pads
coated cover orange, black or white
80 g superfine vellum paper > treasure boxes available
Heftblöcke
Einband aus beschichtetem Karton
orange, schwarz oder weiß
hochfeines Velinpapier 80 g > auch erhältlich in Sets



blocs agrafés « le R »
couverture soft touch orange ou noir
papier vélin velouté ivoire 90 g
«le R» stapled pads
soft touch coated cover orange or black
90 g ivory brushed vellum paper
geheftete Blöcke «le R»
Soft-Touch-Einband orange oder schwarz
elfenbeinfarbenes, samtiges Velinpapier 90 g

48 classic

carnets, blocs, cahiers piqués ou à reliure intégrale
notebooks, and notepads, stapled or with wirebound
Notizbücher, Blöcke, geklammerte Hefte oder mit vollständiger Bindung



carnets et cahiers piqués
couverture carte enduite
orange, noir ou blanc
papier vélin surfin 80 g
staplebound notebooks
coated cover orange, black
or white
80 g superfine vellum paper
*gekammerte Notizbücher
und Hefte*
Einband aus beschichtetem
Karton in Orange, Schwarz
oder Weiß
80 g hochfeines Velinpapier



Notebooks
couverture carte enduite
orange, noir ou blanc
reliure intégrale, papier vélin
surfin 80 g
Notebooks
coated cover orange, black
or white
wirebound, 80 g superfine
vellum paper
Notizbücher
Einband aus beschichtetem
Karton in Orange, Schwarz
oder Weiß.
vollständige Bindung
80 g hochfeines Velinpapier



Notepads
couverture carte enduite
orange ou noir
reliure intégrale
papier vélin surfin 80 g
Notepads
coated cover orange or black
wirebound, 80 g superfine
vellum paper
Notizblöcke
Einband aus beschichte-
tem Karton in Orange und
Schwarz
vollständige Bindung
hochfeines Velinpapier 80 g



Clic Bloc
bloc tapis de souris
papier vélin surfin 80 g
dessous anti-dérapant
Clic Bloc
paper mousepad
80 g superfine vellum paper
nonskid backing
Geklammerte Hefte
Mauspad-Block
80 g hochfeines Velinpapier
rutschfeste Unterseite



carnets Unlimited
couverture pelliculée soft touch orange ou noir
papier vélin surfin 80 g avec pages microperforées
Unlimited notebooks
soft touch coated cover orange or black
80 g superfine vellum paper with microperforated sheets
Unlimited-Notizbücher
Laminierter Soft-Touch-Einband orange oder schwarz
80 g hochfeines Velinpapier mit mikroperforierten Seiten

60 filing

chemises à élastiques 3 rabats
3-flap elasticated folders
Mappen mit Gummizug 3 Klappen

carte enduite orange ou noir 400 g logo Rhodia sérigraphié
double fermeture à élastique orange ou noir 4 oeillets noirs
de maintien
orange or black coated cardboard 400 g
printed Rhodia logo
two-elastic closure
4 black eyelets
*orange oder schwarz beschichteter Karton 400 g Rhodia-Lo-
go im Siebdruckverfahren*
doppelter Gummizugverschluss
orange oder schwarz
4 schwarze Halteösen



64 rhodiactive

blocs & cahiers business 90 g

business notepads & notebooks 90 g

Business Notizbücher & Hefte 90 g



Exabook rechargeables
couverture polypro noir papier vélin surfín 80 g avec règle, intercalaires et pochettes de rangement

refillable organizers black polypro cover 80 g superfine vellum paper with ruler, dividers and pockets

Nachfüllbare Exabooks
schwarzer Polypro-Einband hochfeines 80g hochfeines Velinpapier mit Lineal, Trennblättern und Aufbewahrungsfächern



blocs, carnets et cahiers couverture polypro noir reliure intégrale papier vélin velouté 90 g

notepads and notebooks
black polypro cover wirebound 90 g brushed vellum paper

Blöcke, Notizbücher und Hefte mit schwarzer Polypro-Einband und vollständiger Bindung samtweiches Velinpapier 90 g

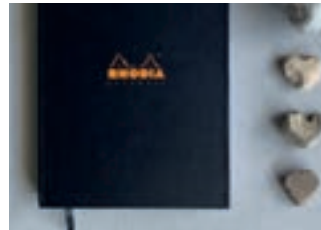

cahiers rembourrés couverture rembourrée noir souple ou rigide brochure ou reliure intégrale papier vélin velouté 90 g

black softback or hardback cover casebound or wirebound 90 g brushed vellum paper

Hefte mit festem Einband schwarz biegsam oder fest im Broschüre-Format oder mit vollständiger Bindung samtweiches Velinpapier 90 g



Greenbook
carnets et cahiers couverture polypro noir recyclé reliure intégrale papier recyclé 90 g certifié FSC

notepads and notebooks
black polypro cover wirebound 90 g recycled paper FSC certified

Notizbücher und Hefte mit schwarzer recycelter Polypro-Einband und vollständiger Bindung 90 g 100 % Recyclingpapier FSC-zertifiziert

78 rhodiatime

agendas et gestion du temps

diaries and time management

Terminkalender und Zeitplaner



Webplanner agendas
rembourrés rigides façon cuir italien, papier ivoire vélin velouté 90 g, sous-mains semainiers non datés, blocs Memo N°11 et N°13

Webplanner agendas
hardcover Italian leatherette ivory brushed vellum paper 90 g undated weekly desk pads N°11 and N°13 Memo pads

Terminkalender Webplanner
fester Einband in italienischer aus italienischem Kunstleder elfenbeinfarbenes samtweiches Velinpapier 90 g, Schreibunterlage
undatierte Wochenplaner, Memoblöcke Nr. 11 und Nr. 13

94 writing

stylos, portemines & crayons

ballpoint pens, mechanical pencils & pencils

Stifte, Druckbleistift & Bleistifte



Multi Pen 3-en-1
2 stylos à bille noir & rouge + 1 portemine, corps aluminium brossé orange, noir, sauge ou or pointes 0,5 mm

Multi Pen 3-in-1
2 ballpoint pens black & red and 1 mechanical pencil brushed aluminium frame orange, black, sage or gold 0,5 mm tips

Multi Pen 3-in-1
2 Kugelschreiber schwarz & rot + 1 Drehbleistift, Gehäuse aus Aluminium
orange, schwarz, Salbei oder gold gebürstet Spitzen 0,5 mm



portemines
corps aluminium brossé orange, noir, argent, sauge, turquoise, bois de rose, rouge, bleu ou or mine 0,5 mm et gomme

mechanical pencils
brushed aluminium frame orange, black, silver, sage, turquoise, rose wood, red, navy or gold 0,5 mm lead and eraser

Druckbleistifte
Gehäuse aus gebürstetem Aluminium orange, schwarz, silber, Salbei, türkis, Rosenholz, rot, blau oder gold 0,5 mm Mine und Radiergummi



crayons à papier
corps bois teinté noir, orange pointe HB et gomme
black wooden body, orange HB lead and eraser

Bleistifte
Gehäuse aus schwarz gebeiztem Holz, orange HB-Spitze und Radiergummi



stylos à bille
corps aluminium brossé orange, noir, argent, sauge, turquoise, bois de rose, rouge, bleu ou or pointe 0,7 mm

ballpoint pens
brushed aluminium frame orange, black, silver, sage, turquoise, rose wood, red, navy or gold 0,7 mm ballpoint tip

Kugelschreiber
Gehäuse aus gebürstetem Aluminium orange, schwarz, silber, Salbei, türkis, Rosenholz, rot, blau oder gold Spitze 0,7 mm

118 rhodiarama

carnets et accessoires

notebooks & accessories

Notizbücher und Zubehör



Goalbook Creation, carnets d'organisation personnalisables couverture rembourrée rigide façon cuir italien papier lavis technique blanc 200 g ou papier Maya noir 120 g avec index, calendrier perpétuel et pochette à soufflet

Goalbook Creation, customizable organisation notebooks hard cover Italian leatherette white blank pen & inkwash paper 200 g or black Maya paper 120 g with index, perpetual calendar and expanding pocket

Goalbook Creation, individuell gestaltbare Notizbücher fester Einband aus italienischem Kunstleder 200 g weißes Lavistechnik-Papier oder 120 g schwarzes Maya-Papier mit Index, Kalender und Faltentasche



Goalbook, carnets d'organisation personnalisables couverture souple ou rembourrée rigide façon cuir italien papier ivoire vélin velouté 90 g avec index, calendrier perpétuel et pochette à soufflet

Goalbook, customizable organisation notebooks soft or hard cover Italian leatherette 90 g ivory brushed vellum paper with index, perpetual calendar and expanding pocket

Goalbook, Notizbücher zum Organisieren individuell gestaltbar weicher oder fester Einband aus italienischem Kunstleder elfenbeinfarbenes samtweiches Velinpapier 90 g mit Index, Kalender und Faltentasche



porte-stylo autoadhésif, façon Italien, logo Rhodia embossé, large passant élastique orange, dos autoadhésif

self-adhesive pen loop, Italian leatherette, embossed Rhodia logo, large orange elastic loop, self-adhesive back

selbstklebender Stifthalter im italienischen Stil mit geprägtem Rhodia-Logo, breiter, orangefarbener Gummizug, selbstklebende Rückseite



Webnotepad et carnets rembourrés rigides façon cuir italien papier ivoire vélin velouté 90 g avec pochette à soufflet

Webnotepad and hardcover notebooks Italian leatherette 90 g ivory brushed vellum paper with expanding pocket

Webnotepad und Notizbücher mit festem Einband aus italienischem Kunstleder elfenbeinfarbenes samtweiches Velinpapier 90 g mit Falttasche



carnets et cahiers souples façon cuir italien papier ivoire vélin velouté 90 g avec pochette à soufflet

softcover notebooks Italian leatherette 90 g ivory brushed vellum paper with expanding pocket

weiche Notizbücher und Hefte aus italienischem Kunstleder elfenbeinfarbenes samtweiches Velinpapier 90 g mit Falttasche



carnets piqûre textile couverture souple façon cuir italien papier ivoire vélin velouté 90 g

sewn spine notebooks soft cover Italian leatherette 90 g ivory brushed vellum paper

geklammerte Textil-Notizbücher weicher Einband aus italienischem Kunstleder elfenbeinfarbenes samtweiches Velinpapier 90 g



conférencier, livret porte-bloc ou carnet, porte-blocs (+ bloc agrafés) façon cuir italien avec porte-crayon et porte-cartes zippered portfolio, small portfolio for notepad or book, notepad covers (+ stapled pads) Italian leatherette pen-loop and name card pocket

Portfolio, Halter für Block oder Notizbuch Blockhalter (+ Heftblock) aus italienischem Kunstleder mit Bleistifthalter und Kartenhalter



trousse plumier et trousse ronde tirette façon cuir italien zip métallique

zippered hard case pencil box and round pencil case Italian leatherette zip puller metallic zipper

Eckiges und rundes Schlampemäppchen Reißverschluss aus italienischem Kunstleder Metallreißverschluss



pochettes zippées Rhodiarama simili cuir italien rembourrage mousse tirette en simili cuir cousu

zipped pouches Italian imitation leather foam padding leatherette puller

Reißverschlussstäschchen Italienisches Kunstleder Schaumstoff-Polsterung

170 rhodiarama home office

accessoires de rangement et d'organisation

storage and organization accessories

Zubehör zum Aufbewahren und Organisieren



supports pour téléphone mobile, sous-mains souples et rigides, porte-revues, porte-courriers, pot à crayons, plumiers, vide-poches, corbeilles, trieurs 4 tiroirs, sets de boîtes façon cuir italien

mobile phone stands, soft and hardback desk pads, magazine racks, letter holders, pencil holders, pencil boxes, tidies, waste bins, 4 drawers storage boxes, sets of nested boxes Italian leatherette

Halterungen für Mobiltelefone

weiche und feste Schreibunterlagen, Zeitschriftenhalter, Briefhalter, Stiftbehälter, Federmäppchen, Ablagen, Körbe, Ordner mit 4 Schubladen, Sets für Schachteln aus italienischem Leder

194 rhodia touch

carnets, blocs et accessoires pour artistes

artbooks, pads and accessories for artists

Skizzenbuch und Blöcke für Künstler



carnets, blocs et accessoires conçus pour calligraphes, urban sketchers, designers, architectes, illustrateurs ou aquarellistes

couvertures façon cuir, carte Maya ou 100 % coton

papiers beaux-arts Clairefontaine réglures novatrices Cross et Cross'n'Dot

artbooks, pads and accessories designed for calligraphers, urban sketchers, designers, architects, illustrators or watercolorists

Italian leatherette, Maya card or 100% cotton cover

Clairefontaine fine arts papers Cross and Cross'n'Dot

innovative rulings

Skizzenbuch, Blöcke und Zubehör für Kalligrafen, Urban Sketchers, Designer, Architekten, Illustratoren oder Aquarellisten

Einband in aus Kunstleder, Maya-Karton oder 100% Baumwolle

Clairefontaine Kunstdruckpapier innovative Lineatur Cross und Cross'n'Dot

240 PAScribe

calligraphy practice & correspondence pads

calligraphy practice & correspondence pads

Kalligrafie-Übungsblöcke & Briefpapier



blocs agrafés pour la pratique de la calligraphie ou de correspondance

couverture carte Maya papiers beaux-arts Clairefontaine fine réglure horizontale grise lignée 6 mm recto/verso

calligraphy practice & correspondence stapled pads

card cover Clairefontaine fine arts papers horizontal 6 mm thin grey lined ruling on both sides

Heftblöcke für Kalligrafie- oder Schreibübungen

Einband aus Maya-Karton

Kunstdruck Clairefontaine feine horizontale graue Lineatur 6 mm Vorder- und Rückseite

244 collection orange botanique

blocs, carnets, home office et accessoires

books and pads, home office and accessories

Notizbuch und Blöcke, Zubehör zum Aufbewahren und Organisieren



blocs, carnets, home office et accessoires

couverture façon cuir ou soft touch

papier ivoire vélin velouté 90 g

books and pads, home office and accessories

Italian leatherette or soft touch cover

90 g vellum brushed paper

Notizbuch und Blöcke, Zubehör zum Aufbewahren und Organisieren

Einband in aus italienischem Kunstleder oder Soft-Touch-Einband

Elfenbeinfarbenes, samtweiches Velinpapier 90 g

Septembre 1934

September 1934

September 1934

Qui aurait pensé qu'un petit bloc agrafé orange paré d'un singulier logo aux lettres biseautées coiffées de deux sapins comme en esquisse pouvait faire le tour du monde ?

En 2023, Rhodia soufflera ses 89 bougies. Mais Rhodia, ce n'est pas seulement une marque patrimoniale pouvant se targuer d'avoir traversé les décennies sans prendre une ride, elle est surtout devenue une marque iconique, qui a su conquérir les passionnés de par le monde et instaurer avec eux un véritable rapport de confiance. Car perdurer... c'est tout un art !

Depuis 89 ans, l'expertise papetière de Rhodia préserve l'excellence et la réputation internationale du «Made in France».

Who would have thought that a little orange stapled notepad with an unusual logo featuring the outline of two fir trees over beveled lettering would go all around the world?

In 2023, Rhodia will celebrate its 89th anniversary. However Rhodia is more than a flagship brand that can proudly claim to have weathered the decades without developing a single wrinkle. It is an iconic brand that has gathered a cult following all over the world and established a genuine, trusting relationship with its customers.

Longevity is an art in itself!

For 89 years, the expertise of Rhodia preserves the excellence and worldwide reputation of the «Made in France» statement.

Wer hätte gedacht, dass ein kleiner orangefarbener Heftblock mit einem einzigartigen Logo mit abgeschrägten Buchstaben und zwei Tannenbäumen wie auf einer Skizze um die Welt gehen könnte?

Im Jahr 2023 wird Rhodia 89 Jahre alt. Doch Rhodia ist nicht nur ein Markenerbe, das die Jahrzehnte überdauert hat, ohne auch nur eine Falte zu bekommen, sondern vor allem eine ikonische Marke, die es geschafft hat, Liebhaber auf der ganzen Welt für sich zu gewinnen und ein echtes Vertrauensverhältnis zu ihnen aufzubauen. Denn das Fortbestehen ist eine Kunst!

Seit 89 Jahren bewahrt Rhodia die Expertise in der Papierherstellung, die Exzellenz und den internationalen Ruf des «Made in France».



Pour «la marque aux deux sapins», la recette de la longévité est simple: un nom, un logo, un style, un produit emblématique, fruits d'un savant mariage de savoir-faire et d'inventivité, alliant héritage et esprit contemporain.

The secret of the longevity of «the brand with the two fir trees» is simple: a name, a logo, a style, an emblematic product, all of which are the results of a clever blend of know-how, inventiveness, heritage and modernity.

Für «die Marke mit den zwei Tannenbäumen» ist das Rezept für Langlebigkeit einfach: ein Name, ein Logo, ein Stil, ein emblematisches Produkt, das Ergebnis einer geschickten Kombination aus Know-how und Erfindungsgeist, die Erbe und Zeitgeist miteinander verbindet.

Un nom

qui traduit tout simplement l'origine rhodanienne de la marque.

Un logo

en lien direct avec son secteur d'activité, représentant deux sapins liés l'un à l'autre et symbolisant les deux frères fondateurs, Henri et Robert Vérilhac. On rapporte qu'il a été esquissé d'un seul trait par Antonia, l'épouse d'Henri Vérilhac, comme une évidence, sur un coin de table. Aujourd'hui encore, ce logo incarne «l'essence» de la marque, à tel point que l'on évoque Rhodia par la circonlocution «la marque aux deux sapins».

Un style

authentique et intemporel, un design de caractère, tout en épure et depuis toujours résolument distinctif.

Un produit

emblématique, le bloc agrafé, né d'une idée très simple: la volonté de créer un outil unique, fonctionnel et universel, combinaison exigeante entre savoir-faire, innovations techniques et esthétique.

A name

that simply reflects the brand's origins by the Rhône River (the people from this region are known as «Rhodanians»).

A logo

that provides a direct link with the industry. The two joined fir trees symbolize the company's founding brothers, Henri and Robert Vérilhac. This logo was reportedly drawn spontaneously in a single stroke by Antonia, Henri Vérilhac's wife, as if it were indisputable. This logo still embodies the «essence» of the brand, to such an extent that Rhodia is often referred to using the circumlocution «the brand with the two fir trees».

A style

that is authentic and timeless, full of character, simple and refined and one that has been unmistakably distinctive ever since it was created.

A product,

the emblematic stapled notepad, which was the result of a very simple idea: the desire to create a unique, practical, universal article that met the demanding challenge of combining know-how, technical innovation and aesthetics.

Ein Name

der ganz einfach die Herkunft der Marke aus der Rhone widerspiegelt.

Ein Logo

mit direktem Bezug zu seinem Geschäftsfeld, das zwei miteinander verbundene Tannenbäume darstellt, die die beiden Gründerbrüder Henri und Robert Vérilhac symbolisieren. Es wird berichtet, dass es von Antonia, der Frau von Henri Vérilhac, wie selbstverständlich mit einem einzigen Strich auf einer Tischecke skizziert wurde. Noch heute verkörpert dieses Logo die «Essenz» der Marke, so dass man Rhodia mit der Umschreibung «die Marke mit den zwei Tannenbäumen» bezeichnet.

Ein Stil

der authentisch und zeitlos ist, charaktervoll, einfach und raffiniert, und der seit seiner Entstehung unverwechselbar ist.

Ein Produkt,

das das Wahrzeichen der Marke ist, der Heftblock, entstand aus einer sehr einfachen Idee: dem Wunsch, ein einzigartiges, funktionales und universelles Schreibgerät zu schaffen, das eine anspruchsvolle Kombination aus Know-how, technischen Innovationen und Ästhetik darstellt.

Naissance d'une icône

Rhône-France: the birth of an icon

Rhône-Frankreich: die Entstehung einer Ikone

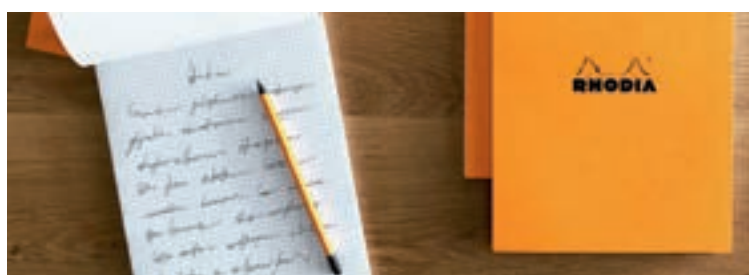

Plus qu'une histoire...

More than a bit of history...

Mehr als nur eine Geschichte...

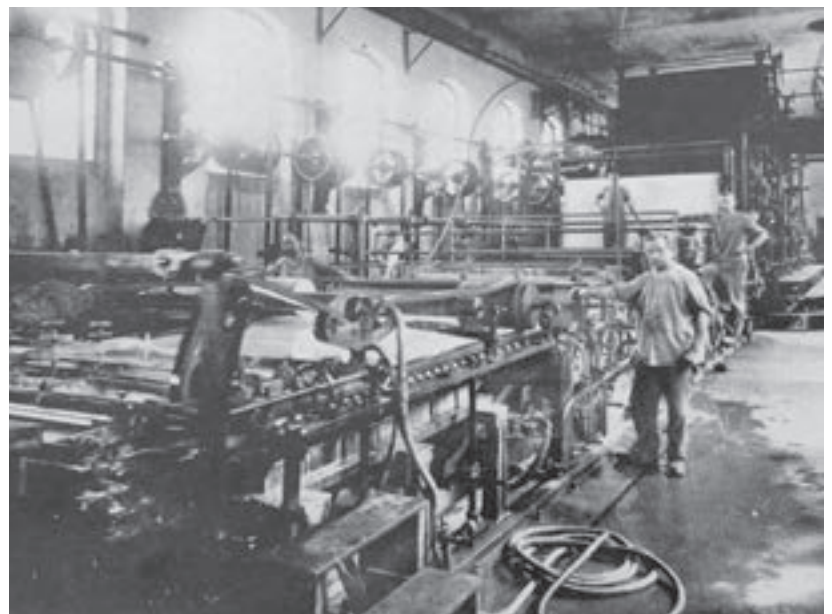
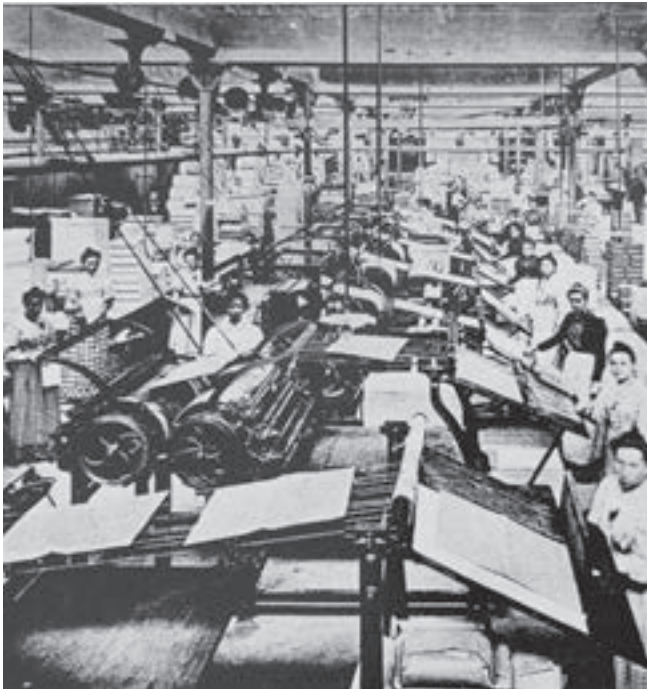

La société «Papeteries Vérilhac Frères» est fondée à Lyon en 1932 par Henri et Robert Vérilhac. Issus d'une famille de négociants en papier, ils s'appuient sur un marché s'étendant de la France à tous les pays d'Afrique du Nord. Ils commercialisent d'abord des cahiers et articles de papeterie, puis, en 1934, se lancent dans la fabrication et la vente de blocs siglés Rhodia.

En 1997, Rhodia est achetée par le groupe Clairefontaine.

Les unités de production sont alors regroupées près de Mulhouse (Haut-Rhin). La société Clairefontaine Rhodia est née.

The stationery firm «Papeteries Vérilhac Frères» was founded in Lyon, France, in 1932 by two brothers, Henri and Robert Vérilhac. They came from a family of paper merchants and their market extended from France across all of North Africa. At first they sold notebooks and stationery products, and then, in 1934, they started manufacturing and selling the Rhodia pads.

In 1997, Rhodia was bought by Clairefontaine.

The production units were then grouped together near Mulhouse (Haut-Rhin, France) and the company Clairefontaine Rhodia was born.

Das Unternehmen «Papeteries Vérilhac Frères» wurde 1932 von Henri und Robert Vérilhac in Lyon gegründet. Sie stammten aus einer Familie von Papierhändlern und konnten sich auf einen Markt stützen, der sich von Frankreich bis in alle nordafrikanischen Länder erstreckte. Sie vermarkteten zunächst Hefte und Schreibwaren, begannen dann aber 1934 mit der Herstellung und dem Verkauf von Blöcken mit dem Rhodia-Siegel.

Im Jahr 1997 wurde Rhodia von der Clairefontaine-Gruppe aufgekauft. Die Produktionsstätten wurden in der Nähe von Mulhouse (Haut-Rhin) zusammengelegt. Es entstand das Unternehmen Clairefontaine Rhodia.



...des valeurs

Une qualité et des finitions irréprochables issues d'une véritable expertise papetière.

Un condensé d'inventivité et d'innovations techniques (carte enduite souple et imperméable, couverture rainurée, agrafes en-tête «Sangrif», sole cartonnée, feuilles détachables microperforées).

Un parti pris esthétique fort et un code couleur précurseur, «orange & black», complémentarité évidente du dynamisme et de l'élégance.

Autant d'exigences qui constituent le «certificat d'authenticité» du bloc Rhodia, un objet épuré, contemporain, quelle que soit l'époque.

Une icône depuis 89 ans, matrice du développement de la marque.

Reconnaisable entre tous, le bloc agrafé Rhodia Orange incarne LE bloc, condense tout le savoir-faire papetier français. Il est la matrice de développement de tous les produits conçus et réalisés aujourd'hui pour s'adapter aux besoins d'un quotidien en mouvement.

Fabriqué en France depuis toujours, le bloc agrafé Rhodia se vend chaque année à des millions d'exemplaires, dans près de 90 pays dans le monde !

...strong values

Irreproachable quality and finishes that are based on a long history of stationery expertise.

Inventiveness and technical innovations (a perfectly waterproof and flexible card cover, a scored cover, «Sangrif» head staples, a stiff back cover, microperforated, removable sheets).

A strong focus on aesthetics and a pioneering «orange & black» color scheme that plays on the obvious complementarity of these two colors to reflect dynamism and elegance.

All these high standards have forged the Rhodia pad's «certificate of authenticity», creating a product that is both stylish and contemporary, whatever the epoch.

For 89 years, this icon has been the matrix for the brand's development.

The Rhodia Orange pad is instantly recognizable and has come to symbolize the quintessential notepad, the distillation of France's finest stationery know-how. It serves as the matrix for the development of all the products that are designed and created today as the company adapts to the needs of today's mobile, changing daily lifestyles.

Every year Rhodia is selling millions of made in France stapled pads in 90 countries worldwide!

...starke Werte

Eine ausgezeichnete Qualität und Verarbeitung, die auf echtem Fachwissen in der Papierherstellung beruht.

Ein Konzentrat aus Erfindungsreichtum und technischen Innovationen (weicher, wasserfester, beschichteter Karton, gerillter Einband, «Sangrif»-Kopfklammern, kartonierter Untergrund, mikroperforierte, abtrennbare Blätter).

Eine starke ästhetische Ausrichtung und ein bahnbrechender Farbcode, «orange & black», eine offensichtliche Ergänzung von Dynamik und Eleganz.

All diese Anforderungen bilden das «Echtheitszertifikat» des Rhodia-Blocks, ein schlichtes, zeitgemäßes Objekt, egal in welcher Epoche.

Seit 89 Jahren eine Ikone als Matrix für die Entwicklung der Marke.

Der unverkennbare Heftblock Rhodia Orange verkörpert DEN Block, kondensiert das gesamte Know-how der französischen Papierherstellung. Er ist die Grundlage für die Entwicklung aller Produkte, die heute konzipiert und hergestellt werden, um sich den Bedürfnissen eines schnelllebigen Alltags anzupassen.

Der Rhodia-Heftblock wird seit jeher in Frankreich hergestellt und jedes Jahr millionenfach in fast 90 Ländern der Welt verkauft!

Le bloc Rhodia

Le bloc RHODIA agrafé en-tête

Avant-gardiste dès sa création en 1934, il s'est immédiatement démarqué des blocs existants grâce à la qualité des matières premières, à sa conception originale et innovante (couverture rainée repliable très résistante) et à sa couleur orange, unique et inimitable.

Caractéristiques qui font son succès depuis 89 ans :

- Couverture carte enduite orange : parfaitement imperméable et très souple
- Couverture rainée repliable : se replie facilement vers l'arrière
- Papier Rhodia vélin surfin 80 g : exceptionnellement blanc et lisse, il permet un meilleur confort d'écriture
- Agrafes en-tête « Sangrif » : les agrafes n'apparaissent pas au dos = pas de risque de se blesser, d'accrocher ses vêtements ou encore de rayer le bureau
- Dessous cartonné ultra rigide : permettant une prise de notes confortable, même sans appui
- Feuilles microperforées : facilement détachables
- Feuilles perforées 2 ou 4 trous (uniquement sur certains formats) : permettant d'intégrer directement un classeur
- À l'instar du bloc agrafé, tous les produits Rhodia sont fabriqués avec du papier Rhodia ou Clairefontaine certifié PEFC.

Aujourd'hui

Le bloc Rhodia - toujours chic! - s'est subtilement adapté à l'air du temps et s'habille aussi de noir ou de blanc, ou se décline dans un colorama très tendance.

Le bloc Black

Parce que Rhodia, c'est «orange & black» depuis 1934!
Une déclinaison qui joue sur le contraste et la complémentarité des couleurs orange et noir, qui font l'identité de la marque depuis toujours.

Une ligne White, tout en épure

Clin d'oeil au numérique et incarnant à la perfection l'intemporalité du bloc Rhodia. Comme l'affirmation éclatante de l'incroyable modernité du design original!

Haut en couleur !

Avec les blocs coloR, tout en velouté, de la couverture au papier.

The head stapled RHODIA pad

The Rhodia notepad was very avant-garde when it was created in 1934, and instantly overshadowed existing notepads because of the quality of its materials, its original and innovative design (a highly resistant scored front cover) and its unique, inimitable orange cover.

The product characteristics that have made its success for the last 89 years:

- Orange coated card cover: perfectly waterproof & flexible cover is scored to neatly fold back
- Superfine vellum Rhodia paper 80 g: white and exceptionally smooth satin finish
- «Sangrif»: staples do not appear on back
- Stiff back cover makes writing easy and portable
- Micro-perforated sheets for easy and clean removal
- 2 or 4 holes punched sheets (limited to some models): to be accommodated in binders
- Stapled notepads as well as all other Rhodia products are made with PEFC certified paper.

The Rhodia pad is still chic today!

It has adapted to the times and is now available in both black and white, but also in trendy colors.

The Black pad

Because Rhodia has been «orange & black» since 1934!
This version plays on the contrast and complementarity of the brand's trademark black and orange colors.

The White range

An implied reference to the digital universe, it also embodies the timeless qualities of the Rhodia pad perfectly. It unquestionably proclaims the incredible modernity of the original design!

Colorful!

As their name indicates, coloR notepads come in bold tints with smooth, velvety covers and paper!

Der am Kopfende geheftete RHODIA-Block

Seit seiner Entstehung im Jahr 1934 war er Avantgarde und hob sich dank der Qualität der Rohstoffe, seines originellen und innovativen Designs (sehr widerstandsfähiger, faltbarer Falzeinband) und seiner einzigartigen und unnachahmlichen orangefarbenen Farbe sofort von den bestehenden Blöcken ab.

Eigenschaften, die seinen Erfolg seit 89 Jahren ausmachen:

- Orange beschichteter Kartoneinband: absolut wasserdicht und sehr biegsam
- Faltbarer Falzeinband: lässt sich leicht nach hinten falten.
- Hochfeines Rhodia-Velinpapier 80 g: außergewöhnlich weiß und glatt, ermöglicht einen besseren Schreibkomfort
- Sangrif-Kopfklammern: Die Klammern erscheinen nicht auf der Rückseite = kein Risiko, sich zu verletzen, an der Kleidung hängen zu bleiben oder den Schreibtisch zu zerkratzen.
- Ultraharte Pappunterseite: ermöglicht bequemes Notieren auch ohne Stütze.
- Mikroperforierte Blätter: leicht abtrennbar
- Perforierte Blätter mit 2 oder 4 Löchern (nur bei bestimmten Formaten): ermöglichen die direkte Übernahme in einen Ordner.
- Wie der Heftblock werden alle Rhodia-Produkte aus PEFC-zertifiziertem Rhodia- oder Clairefontaine-Papier hergestellt.

Der Rhodia-Block ist noch heutzutage angesagt!

Er hat sich der Zeit angepasst und ist jetzt sowohl in Schwarz und Weiß als auch in trendigen Farben erhältlich.

Der schwarze Block

Denn Rhodia ist seit 1934 «orange & schwarz»!
Diese Version spielt mit dem Kontrast und der Komplementarität der Farben Schwarz und Orange, dem Markenzeichen der Marke.

Die Produktreihe White

Als impliziter Verweis auf die digitale Welt verkörpert er auch perfekt die zeitlosen Qualitäten des Rhodia-Blocks. Er verkörpert zweifellos die unglaubliche Modernität des ursprünglichen Designs!

Farbenfroh!

Wie der Name schon sagt, sind die Notizblöcke von coloR in kräftigen Farben gehalten und haben ein samtweiches, glattes Papier und Einband!

The Rhodia pad



Photos non contractuelles - Photos are not contractually binding - Bild vertraglich nicht bindend

Secrets de fabrication

Our manufacturing secrets

Die Geheimnisse der Fertigung

C'est dans notre usine, à Mulhouse, en Alsace, que tous les blocs Rhodia sont fabriqués. L'usine date de 1840 !

All the Rhodia notepads are manufactured in the Alsace region of eastern France, at our plant in Mulhouse, which dates back to 1840!

Alle Rhodia-Notizblöcke werden im Elsass in Ostfrankreich hergestellt, in unserem Werk in Mulhouse, welches seit dem Jahr 1840 stammt!



1 - Le papier arrive directement de notre usine d'Étival, dans les Vosges. 16 000 mètres se préparent à être déroulés au travers de plusieurs cylindres pour assurer une tension parfaite pour l'impression.

2 et 3 - Carreaux, lignes ou dots viennent se poser sur le papier par le biais des cylindres encrés.



1 - The paper is delivered straight from our mill in Étival, a town in the nearby Vosges region. Here, a 16,000 metre reel is being fed through several cylinders to obtain just the right tension for printing.

2 and 3 - Grids, lines or dots are printed onto the paper with inked cylinders.

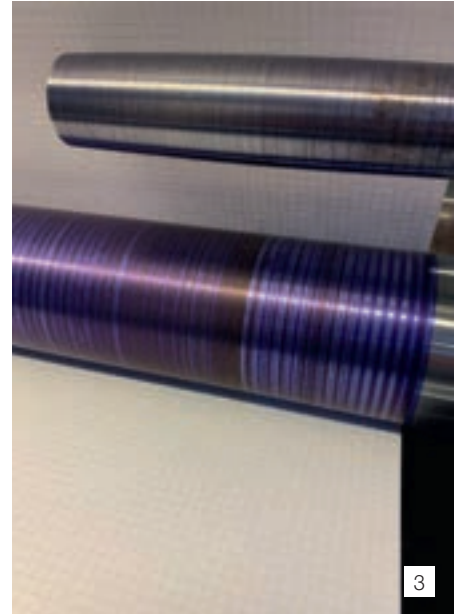

1 - Das Papier kommt direkt aus unserer Fabrik in Étival in den Vogesen. 16.000 Meter werden darauf vorbereitet, durch mehrere Walzen abgerollt zu werden, um eine perfekte Spannung für den Druck zu gewährleisten.

2 und 3 - Karos, Linien oder Pünktchen kommen mithilfe von Farbzylindern auf das Papier.

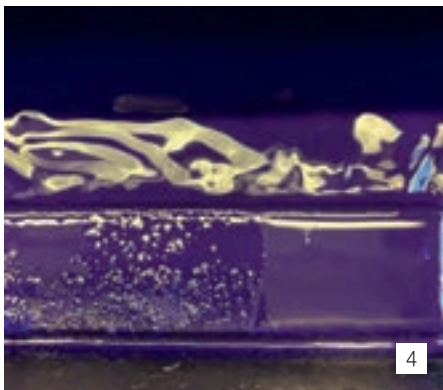

4 - La réglure du papier est imprimée avec une encre à l'eau.

5 - Les microperforations qui serviront à détacher les feuillets du bloc sont réalisées à la suite de l'impression.

6 - Puis intervient le comptage et l'assemblage des 80 feuillets qui composeront les blocs.

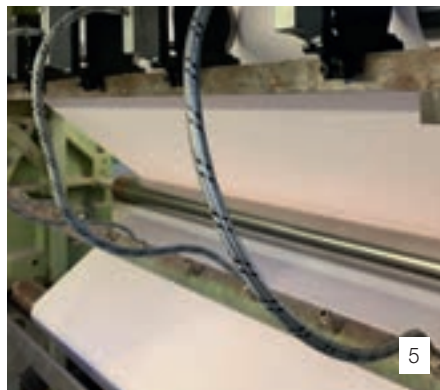

4 - The ruling is printed with water-based ink.

5 - The microperforations, for easy sheet removal, are made once the rulings have been printed.

6 - Then, the 80 sheets that make up each notepad block, are counted and assembled.



4 - Die Lineatur des Papiers wird mit wasserbasierter Tinte gedruckt.

5 - Die Mikroperforationen, die zum Abtrennen der Blätter vom Block dienen, werden nach dem Drucken angebracht.

6 - Dann folgt das Zählen und Zusammensetzen der 80 Blätter, aus denen die Blöcke bestehen werden.

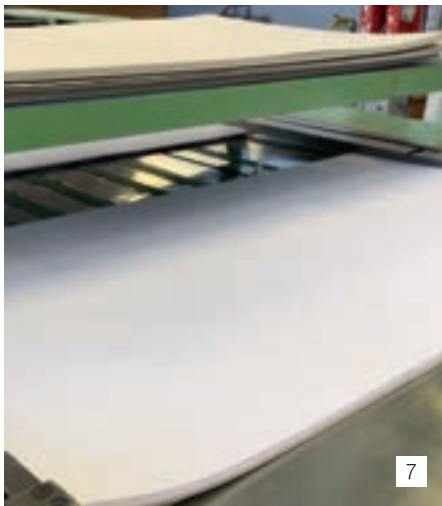

7

7 - La dépose de la sole.
La sole est le dessous cartonné du bloc.
Ce support garantit un maintien parfait
lorsque vous écrivez sans support.

8 - La première découpe intervient puis
la colle de reliure est déposée pour
encoller le bloc et le carton.

9 - La couverture est rainée puis déposée
sur le bloc.



8

7 - The cardboard backing is positioned.
This stiff back cover ensures that the
pad holds its shape, providing support
if you don't have anything to lean on.

8 - The first cutting phase takes place.
Then, the adhesive is applied to bind
the paper and cardboard together.

9 - The front cover grooves are made
and the cover is then positioned on top
of the notepad block.

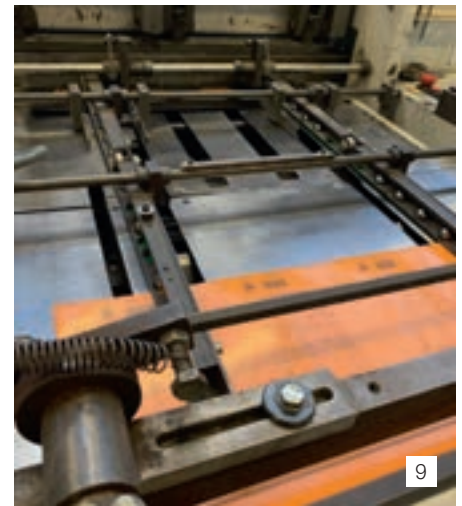

9

7 - Das Ablegen der Sohle.
Die Sohle ist die kartonierte Unterseite
des Blocks. Diese Unterlage sorgt für
einen perfekten Halt, wenn Sie ohne
Unterlage schreiben.

8 - Der erste Schnitt erfolgt, dann wird
der Buchbinderleim aufgetragen, um
den Block und den Karton zu verleimen.

9 - Der Einband wird mit Rillen versehen
und dann auf den Block gelegt.



10

10 - Les agrafes sont posées sur le bloc
selon un procédé unique, le « Sangrif ».
Ainsi, elles n'apparaissent pas au dos,
ce qui évite tout risque de se blesser,
d'accrocher ses vêtements ou de rayer son
bureau.

11 - Encollage de la couverture.

12 - Dernière étape de fabrication, la
découpe du bloc au format final.
Enfin, le conditionnement, l'encaisseage
et l'étiquetage suivront... pour mener les
blocs jusqu'aux boutiques des quatre
coins du monde.

13 - L'homme est présent à toutes les
étapes de fabrication. Il programme les
machines, les pilote, effectue les réglages
nécessaires à chaque étape et surveille
toutes les opérations.



12

10 - The staples are inserted using a
unique process, known as "Sangrif".
This leaves no staples exposed on
the back of the pad, so you won't hurt
yourself, get them caught on your
clothes, or scratch your desk.

11 - The cover is glued to the top end
of the notepad block and then folded
over.

12 - The final cutting is the last stage of
the manufacturing process.
Actually, the notepads are then
packaged, crated and labelled for
dispatch to shops all over the world.

13 - Humans are involved at every
stage of the manufacturing process.
They program the machines, control
them, make the adjustments for each
manufacturing stage, and supervise all
the operations.

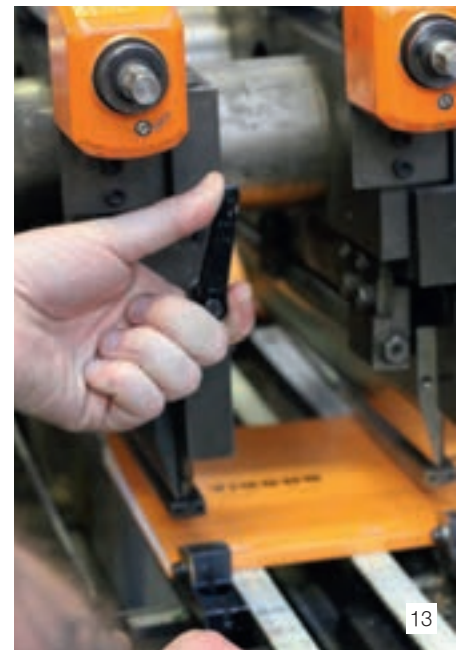

13

10 - Die Klammern werden nach einem
einzigartigen Verfahren, dem «Sangrif»,
auf den Block gesetzt. So erscheinen
sie nicht auf der Rückseite und es
besteht keine Gefahr, dass man sich
verletzt, an der Kleidung hängen bleibt
oder den Schreibtisch zerkratzt.

11 - Verleimen des Einbands

12 - Letzter Herstellungsschritt, das
Zuschneiden des Blocks auf das
Endformat.
Schließlich folgen die Verpackung, das
Einschweißen und die Etikettierung, um
die Blöcke bis zu den Geschäften in
allen Ecken der Welt zu bringen.

13 - Der Mensch ist in allen
Fertigungsschritten anwesend. Er
programmiert die Maschinen, steuert
sie, nimmt die für jeden Schritt
notwendigen Einstellungen vor und
überwacht alle Vorgänge.

Papier et environnement

Inscrit dans la défense de l'environnement

Contrairement aux idées reçues, l'industrie du papier s'inscrit parfaitement dans la défense de l'environnement. Ainsi, pour fabriquer ses papiers de grande qualité, Clairefontaine utilise majoritairement des fibres issues de déchets de scieries ou de coupes d'éclaircies. Le concept de déforestation se révèle erroné, seule la périphérie du bois s'utilise pour fournir ces fibres, le coeur étant destiné à l'ameublement et à la construction. L'éclaircissement des forêts favorise leur biodiversité, la gestion de l'eau, la santé des arbres. Les certifications PEFC et FSC® en permettent d'ailleurs un suivi encore plus net, aident à respecter l'équilibre forêt-gibier, à préserver les arbres remarquables, à planter des espèces variées, à préparer des sols, etc. Oui, Clairefontaine protège les forêts et, pour donner l'exemple, entretient des centaines d'hectares dans les Vosges. La maîtrise de l'eau reste aussi un enjeu majeur, Clairefontaine possède sa propre station de traitement, remarquée par un trophée officiel. Chaque année, sa production de papiers consomme moins d'énergie, limite ses émissions dans l'air. Et Clairefontaine adopte cette démarche responsable jusqu'à l'impression des papiers et au façonnage des articles de papeterie, avec un contrôle rigoureux des encres et des colles utilisées. Le caractère végétal des fibres en fait un matériau entièrement recyclable, car elles proviennent d'une ressource renouvelable. Leur utilisation n'entraîne pas de prélèvement dans un stock fini de matières premières, comme le sont les matières fossiles. Près de Reims, Everbal, filiale de Clairefontaine, ne fabrique que des papiers recyclés. Pour Clairefontaine, la production de papiers et d'articles de papeterie peut vraiment s'appeler opération industrielle verte !

We certify that our brands are environmentally friendly

Contrary to popular belief, the paper industry slots perfectly into protection of the environment. Therefore, to manufacture its high-quality papers, Clairefontaine mainly uses fibres from sawmill wastes or from pruned or thinned trees. It appears that the concept of deforestation is incorrect, only the outer wood is used to provide these fibres, the heart of the wood being intended for furniture and construction. Forest thinning promotes biodiversity, water management, and the health of trees. PEFC and FSC® certifications furthermore, facilitates an even clearer surveillance, which helps with respecting the equilibrium between a forest and its wildlife, the preservation of outstanding tree specimens, planting varieties of species, and the preparation of soils, etc. Clearly Clairefontaine plays a role in protecting forests and, as an example, maintains hundreds of hectares of forest in the Vosges. Water management and conservation remain a major challenge, Clairefontaine has its own treatment plant, which has been recognised by the award of an official Trophy. Every year, its paper manufacturing consumes less energy, and lowers its emissions into the air. What's more, Clairefontaine adopts this responsible type of approach right up to its paper printing and stationery manufacturing activities, by exercising rigorous checks of the inks and glues used. The plant-based nature of the fibres makes their paper a fully recyclable material because it comes from a sustainable resource. Its use does not result in the removal of a finite stock of raw materials, as is the case with fossil fuels. Near Reims, Everbal, which is a subsidiary of Clairefontaine, only manufactures recycled papers. For Clairefontaine, the production of paper and stationery can genuinely be called "Green" industrial operation.

Wir zertifizieren, dass unsere Marken umweltfreundlich sind.

Entgegen der landläufigen Meinung ist die Papierindustrie ein wichtiger Teil des Umweltschutzes. So verwendet Clairefontaine für die Herstellung seiner hochwertigen Papiere überwiegend Fasern, die aus Sägewerksabfällen oder Durchforstungsholz stammen. Das Konzept der Entwaldung stellt sich als falsch heraus, da nur die Peripherie des Waldes für die Bereitstellung dieser Fasern genutzt wird, während das Herz des Waldes für die Möbel- und Bauindustrie bestimmt ist. Die Durchforstung der Wälder fördert die Artenvielfalt, das Wassermanagement und die Gesundheit der Bäume. Die PEFC- und FSC®-Zertifizierungen ermöglichen übrigens eine noch deutlichere Überwachung, helfen dabei, das Gleichgewicht zwischen Wald und Wild zu wahren, herausragende Bäume zu erhalten, verschiedene Arten anzusiedeln, den Boden vorzubereiten usw. Ja, Clairefontaine schützt die Wälder und pflegt, um ein Beispiel zu geben, Hunderte von Hektar in den Vogesen. Auch die Kontrolle des Wasserverbrauchs bleibt ein wichtiges Thema. Clairefontaine besitzt eine eigene Wasseraufbereitungsanlage, die durch die Auszeichnung mit einer offiziellen Trophäe hervorgehoben wurde. Jedes Jahr wird bei der Papierproduktion weniger Energie verbraucht und die Emissionen in die Luft begrenzt. Und Clairefontaine übernimmt diesen verantwortungsbewussten Ansatz bis hin zum Druck der Papiere und der Verarbeitung der Papierwaren, mit einer strengen Kontrolle der verwendeten Tinten und Klebstoffe. Der pflanzliche Charakter der Fasern macht sie zu einem durchweg recycelbaren Material, da sie aus einer erneuerbaren Ressource stammen. Ihre Verwendung bedeutet keine Entnahme aus einem endlichen Rohstoffbestand, wie es bei fossilen Stoffen der Fall ist. In der Nähe von Reims stellt Everbal, eine Tochtergesellschaft von Clairefontaine, ausschließlich Recyclingpapier her. Für Clairefontaine kann die Herstellung von Papier und Schreibwaren wirklich grüne Industrieproduktion genannt werden!





Le papier Clairefontaine est fabriqué à Étival-Clairefontaine, dans les Vosges, toujours sur la même machine. Ses caractéristiques témoignent d'un équilibre subtil :

- sa force permet une opacité et une résistance supérieure, comme le pliage aisé des feuilles,
- son satinage est d'une régularité parfaite pour que la plume glisse aisément, pas trop accentué afin que la pointe ne patine pas,
- son collage est irréprochable pour que l'encre et la pointe feutre ne buvardent pas, mais dosé pour laisser le papier amoureux de l'écriture,
- sa formation est totalement homogène grâce au choix des pâtes à papier, au raffinage et à l'égouttage progressif des fibres, ce qui permet ensuite l'impression de lignes fines, précises et une écriture facile,
- sa blancheur fait apparaître clairement le texte, sans éblouir les yeux.

The Clairefontaine paper is made in Etival-Clairefontaine, in the Vosges, always on the same machine. Its characteristics reflect a subtle balance:

- its strength provides superior opacity and strength, such as easy folding of the sheets,
- its satin finish is perfectly regular so that the feather glides easily, not too sharp so that the tip does not slip,
- its gluing is irreproachable so that the ink and felt tip do not blot, but measured to leave the paper in love with writing,
- its formation is totally homogeneous thanks to the choice of paper pulp, the refining and progressive draining of the fibres, which then allows the printing of fine, precise lines and easy writing,
- its whiteness makes the text appear clearly, without dazzling the eyes

Clairefontaine-Papier wird in Étival-Clairefontaine in den Vogesen hergestellt, und das stets auf der gleichen Maschine. Seine Eigenschaften zeugen von einem subtilen Gleichgewicht:

- *seine Stärke ermöglicht eine höhere Blickdichte und Festigkeit, ebenso wie das einfache Falten der Blätter,*
- *seine Satinierung ist von perfekter Gleichmäßigkeit, damit die Feder leicht gleitet, nicht zu stark betont, damit die Spitze nicht ansetzt,*
- *seine Leimung ist makellos, damit die Tinte und die Filzspitze nicht verschmieren, aber dosiert, damit das Papier die Handschrift liebkost,*
- *seine Formation ist dank der Wahl des Papierbreis, der Verfeinerung und der allmählichen Entwässerung der Fasern völlig homogen, was anschließend den Druck feiner, präziser Linien und ein leichtes Schreiben ermöglicht,*
- *seine Weiße lässt den Text klar und deutlich erscheinen, ohne die Augen zu blenden.*

Des labels garantissant notre engagement

Our main environmental certifications

Siegel, die unser Engagement gewährleisten

PEFC



Programme de reconnaissance des certifications forestières.

Cet organisme non gouvernemental indépendant a développé un ensemble de critères à satisfaire pour promouvoir une gestion forestière durable. Les certifications nationales forestières satisfaisant ces critères peuvent prétendre à la reconnaissance par PEFC.

Program for Endorsement of Forest Certification.

An international non-profit, non-governmental organization dedicated to promoting sustainable forest management, the PEFC Certification is the certification system of choice for small forest owners.

Programm zur Anerkennung von Waldzertifizierungen.

Diese unabhängige, nichtstaatliche Organisation hat eine Reihe von Kriterien entwickelt, die erfüllt werden müssen, um eine nachhaltige Forstwirtschaft zu fördern. Nationale Forstzertifizierungen, die diese Kriterien erfüllen, können sich um die Auszeichnung durch PEFC bewerben.



FSC



La marque de la gestion forestière responsable
FSC® C002321

Le Forest Stewardship Council FSC est une organisation non gouvernementale indépendante à but non lucratif créée pour promouvoir une gestion écologiquement appropriée, socialement bénéfique et économiquement viable des forêts du monde. Selon la vision de FSC, les forêts de la planète doivent répondre aux droits et besoins sociaux, écologiques et économiques de la génération actuelle, sans compromettre ceux des générations futures.

The Forest Stewardship Council FSC is an independent, non-profit, non-governmental organisation established to promote environmentally appropriate, socially beneficial and economically viable management of the world's forests. According to FSC's vision, the world's forests should meet the social, ecological and economic rights and needs of the current generation, without compromising those of future generations.

Der Forest Stewardship Council FSC ist eine unabhängige, gemeinnützige Nichtregierungsorganisation, die gegründet wurde, um eine ökologisch angemessene, sozial vorteilhafte und wirtschaftlich tragfähige Bewirtschaftung der Wälder der Welt zu fördern. Nach der Vision des FSC sollen die Wälder der Welt die sozialen, ökologischen und wirtschaftlichen Rechte und Bedürfnisse der heutigen Generation erfüllen, ohne die der zukünftigen Generationen zu gefährden.

Communication

Aujourd'hui...

Plus que jamais, Rhodia cultive son esprit contemporain et vous invite à partager ses valeurs sur le web. Avec des posts quotidiens et une présence forte sur les réseaux sociaux, la « marque aux deux sapins » communique en 4.0 ! Des images élégantes, une mise en ambiance des produits de la marque dans un style actuel et des jeux-concours attrayants font jour après jour grandir la communauté des Rhodiaddicts (Instagram, Facebook, Twitter, Pinterest, ainsi que notre chaîne Youtube) ! À 89 ans, le bloc Rhodia ne cesse de rajeunir !

Today more than ever, Rhodia nurtures its contemporary spirit and invites you to share its stories and values on the web. With daily posts and a strong presence on social networks, the “brand with two fir trees” communicates in 4.0! Elegant images, a presentation of the products in a very contemporary style and attractive contests make the Rhodiaddicts community (Instagram, Facebook, Twitter, Pinterest, as well as our Youtube channel) grow day after day! At 89 years of age, the Rhodia notepad is getting younger and younger!

*Mehr denn je pflegt Rhodia seinen Zeitgeist und lädt Sie ein, seine Werte im Internet zu teilen. Mit täglichen Posts und einer starken Präsenz in den sozialen Netzwerken kommuniziert die «Marke mit den zwei Tannenbäumen» in 4.0!
Elegante Bilder, eine zeitgemäße Untermalung der Markenprodukte und attraktive Gewinnspiele lassen die Gemeinschaft der Rhodiaddicts Tag für Tag wachsen (Instagram, Facebook, Twitter, Pinterest, sowie unser Youtube-Kanal)!
Mit 89 Jahren wird der Rhodia-Block immer jünger!*

www.bloc-rhodia.com

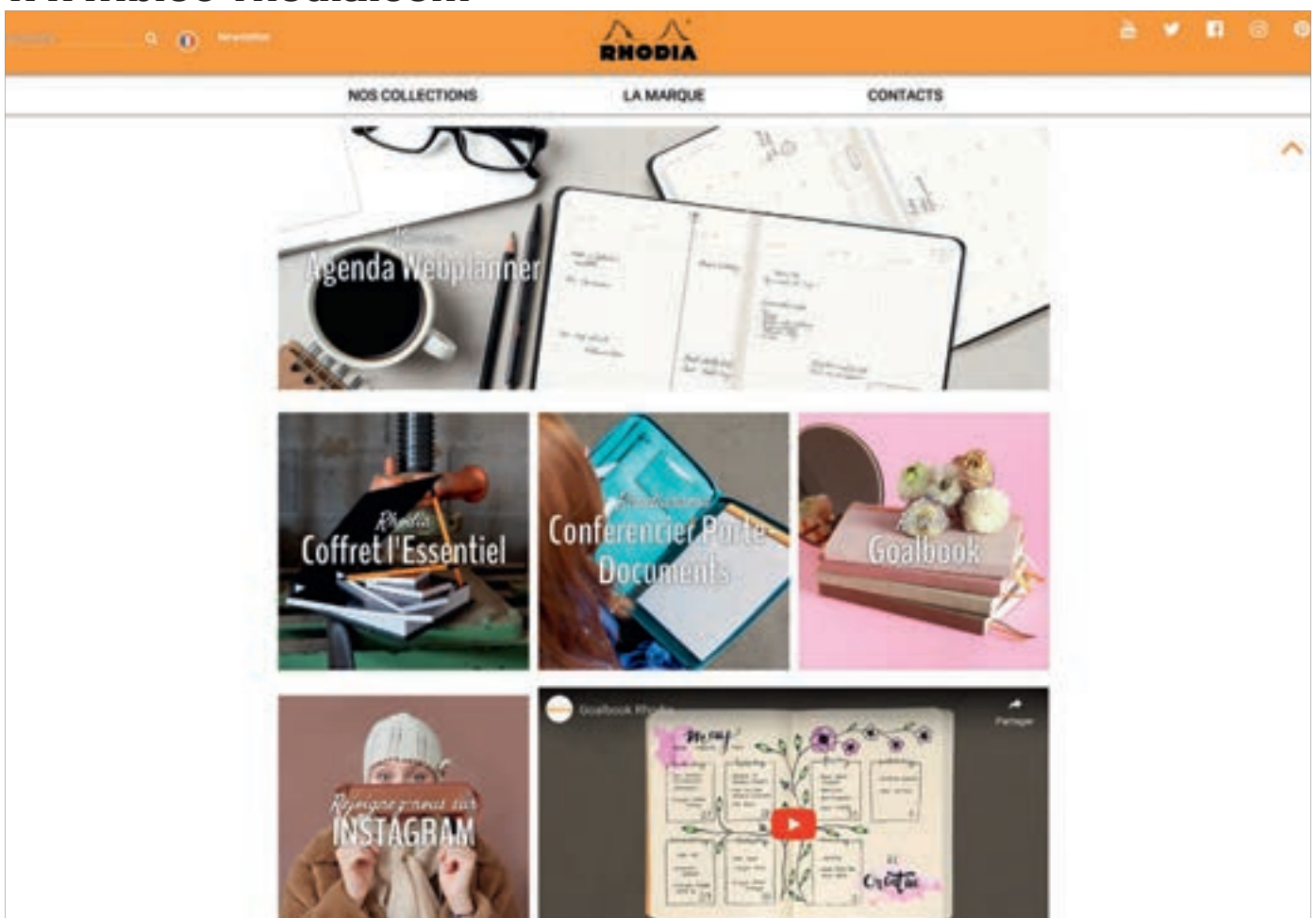

Découvrez un site entièrement repensé pour une navigabilité optimale, avec de nouvelles fonctionnalités et rubriques pratiques telles que « Commerce Connector » (boutiques en ligne) ou « Où acheter ? » et sa carte de géolocalisation des revendeurs / distributeurs. Le catalogue intégral est également disponible en ligne avec une navigation par chapitre, un zoom haute définition, des marque-pages et la possibilité de le partager.

Discover a completely redesigned website with optimal navigability, new practical functionalities and sections such as «Commerce Connector» (online shops) or «Where to buy?» and its geolocation map of resellers/distributors. The complete catalogue is also available online with chapter navigation, high definition zoom, bookmarks and the opportunity to share it.

Entdecken Sie eine völlig neu gestaltete Website mit optimaler Navigationsfähigkeit, neuen Funktionen und praktischen Rubriken wie «Commerce Connector» (Online-Shops) oder «Wo kaufen?» mit seiner Geolokalisierungskarte der Händler / Vertriebspartner. Der vollständige Katalog ist nun ebenfalls online verfügbar, mit einer Navigation nach einzelnen Kapiteln, einem hochauflösenden Zoom, Lesezeichen und der Möglichkeit, ihn zu teilen.

www.bloc-rhodia.com

Instagram

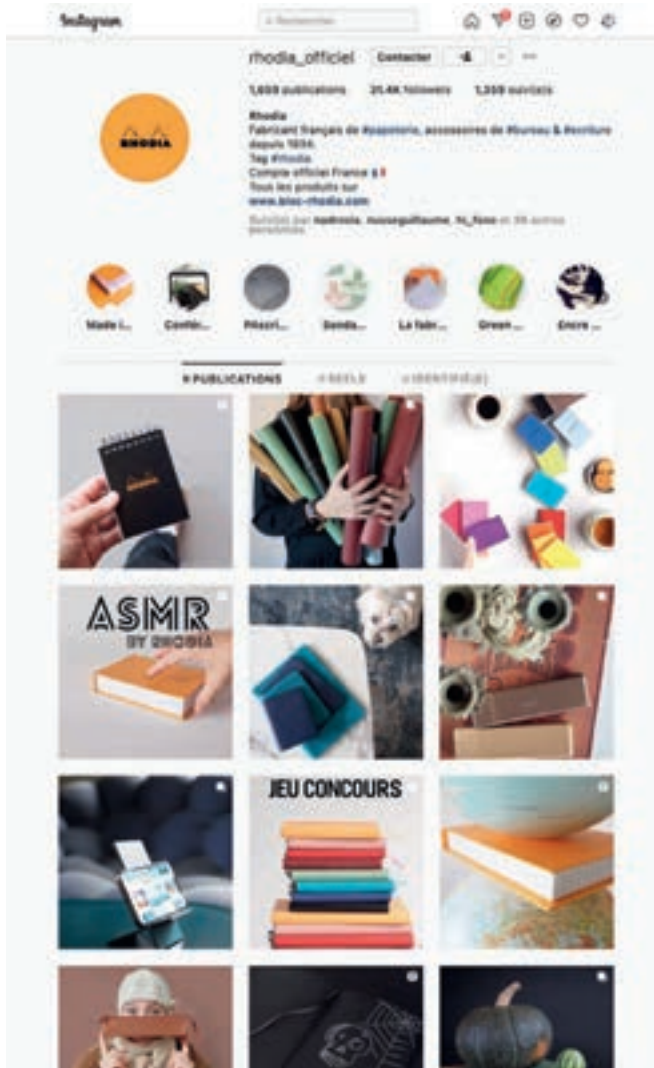

Les plus belles photos Rhodia sont sur Instagram.
The most beautiful pictures are on Instagram.
Die schönsten Rhodia-Fotos gibt es auf Instagram.
https://www.instagram.com/rhodia_officiel/

Exaclairshop



www.exaclairshop.eu
La boutique en ligne dédiée aux distributeurs et revendeurs*.
Passez simplement et rapidement commande, à tout moment!
The online ordering system for dealers and retailers*.
Shop with ease at your convenience!
Das Online-Bestellsystem für Händler und Wiederverkäufer*.
Einfach und bequem einkaufen!

Facebook



Rejoignez-nous sur Facebook. Les fans peuvent y retrouver des photos exclusives, discuter de leur marque favorite, poster des photos de leurs Rhodia...

Find us on Facebook! Exclusive photos, posters, news... We love to hear from Rhodia fans, notebook aficionados and people who want to know more about our notepads and others products.

Besuchen Sie uns auf Facebook. Dort können Fans exklusive Fotos finden, über ihre Lieblingsmarke diskutieren und Fotos ihrer Rhodia posten...

www.facebook.com/BlocRhodia

Pinterest

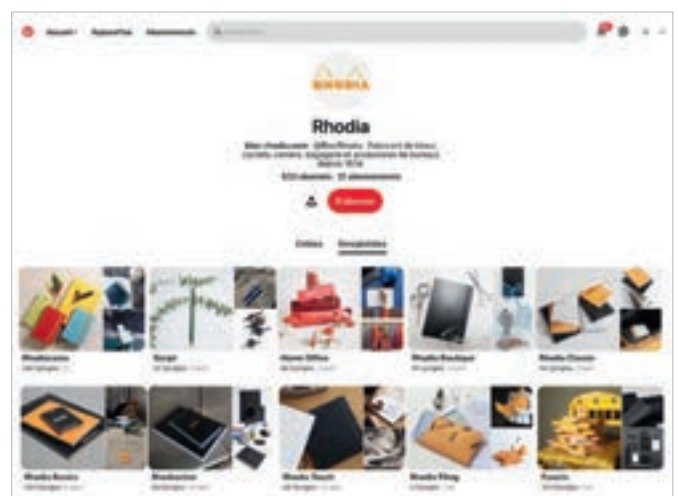

Plein la vue ! Rhodia... en images sur Pinterest.

Discover Rhodia in pictures on Pinterest.

Entdecke Rhodia in Bildern auf Pinterest.

www.pinterest.com/BlocRhodia/

Twitter



www.twitter.com/RhodiaOfficiel



Webplanner 2024

8 coloris, 2 formats / 8 colors, 2 sizes /
8 Farben, 2 Formate

p. 80



Pochettes zippées Rhodiarama

Rhodiarama zipped pouches
Rhodiarama Reißverschlusstäschchen

3 formats , 32 coloris / 3 sizes, 32 colors /
3 Formate, 32 Farben

p. 164



Porte-stylo autoadhésif

Self-adhesive pen loop
Selbstklebender Stifthalter

32 coloris / 32 colors /
32 Farben

p. 150

Photos non contractuelles - Photos are not contractually binding - Bild vertraglich nicht bindend



Stylo et portemine scRipt

scRipt ballpoint pen and mechanical pencil
scRipt Stifte und Druckbleistift

9 coloris / 9 colors /
9 Farben

p. 100



Multi Pen 3-en-1 scRipt

3-in-1 Multi Pen scRipt

4 coloris / 4 colors /
4 Farben

p. 98



**Greenbook cahier éco-responsable
100 % recyclé/recyclable**

Eco-responsible notebook 100 % recycled/recyclable
Ökofreundliches Notizbuch 100 % recycelt/wiederverwertbar

2 formats / 2 sizes /
2 Formate

p. 68

Photos non contractuelles - Photos are not contractually binding - Bild vertraglich nicht bindend



Watercolor Book

Watercolor Book
Watercolor Book

Papier aquarelle grain fin ou satiné
Hot-pressed or cold-pressed watercolor paper
Satinert oder fein gekörntes Aquarellpapier

p. 198



Mixed Media Book

Mixed Media artbook
SkizzenBuch Multitechnik

p. 210



Trousse 2-en-1 pour artiste

2-in-1 case for artists
2-in-1-Künstlermäppchen

p. 235



Carton à dessin

Art folder
Kunstmappe

2 formats / 2 sizes /
2 Formate

p. 236

Photos non contractuelles - Photos are not contractually binding - Bild vertraglich nicht bindend



Collection Orange botanique

Orange Botanique Collection
Kollektion Orange Botanique

p. 244



Photos non contractuelles - Photos are not contractually binding - Bild vertraglich nicht bindend



**Iconique
Essentiel
Ultra-fonctionnalité**

Iconic - Essential - Ultra-functional

Ikonisch - Unverzichtbar - Ultra-funktionell



rhodia basics

Blocs agrafés

Head stapled pads

Heftblöcke

	N°10		N°11		N°12			N°13		N°14		N°15		N°16																															
format size - Format			A7					A6				A5		A5																															
dim. (cm)	5,2 X 7,5		7,4 X 10,5		8,5 X 12			10,5 X 14,8		11 X 17		14,8 X 21		14,8 X 21																															
dim. (in)	2 X 2.9		2.9 X 4.1		3.3 X 4.7			4.1 X 5.8		4.3 X 6.7		5.8 X 8.3		5.8 X 8.3																															
papier paper Papier	blanc white weiß		blanc white weiß		blanc white weiß			blanc white weiß		blanc white weiß		blanc white weiß		blanc white weiß		jaune yellow gelb																													
grammage weight Grammatur	80 g/m2		80 g/m2		80 g/m2			80 g/m2		80 g/m2		80 g/m2		80 g/m2																															
perforation punched Lochung																																													
réglure ruling Lineatur	5/5	ligné lined liniert	5/5	ligné lined liniert	5/5	ligné lined liniert	dot	5/5	ligné lined liniert	5/5	ligné lined MESSAGE	5/5	L+M	5/5	L+M	uni blank blanko	dot	MEETING	5/5																										
couverture cover Umschlag	[Orange/Black]		[Orange/Black]		[Orange/Black]			[Orange/Black]	[Orange/Black]	[Orange/Black]	[Orange/Black]	[Orange/Black]	[Orange/Black]	[Orange/Black]	[Orange/Black]	[Orange/Black]	[Orange/Black]	[Orange/Black]	[Orange/Black]	[Orange/Black]																									
référence item # Referenz	10200C	102009C	10600C	106009C	11200C	112009C	11201C	11600C	116009C	11601C	12200C	122009C	12201C	12600C	126009C	12601C	12558C	12559C	13200C	132009C	13201C	13600C	136009C	13601C	14200C	142009C	14600C	146009C	14000C	15200C	15600C	16200C	162009C	16201C	16600C	166009C	16601C	16000C	160009C	16558C	16559C	16400C	164009C	16401C	16260C

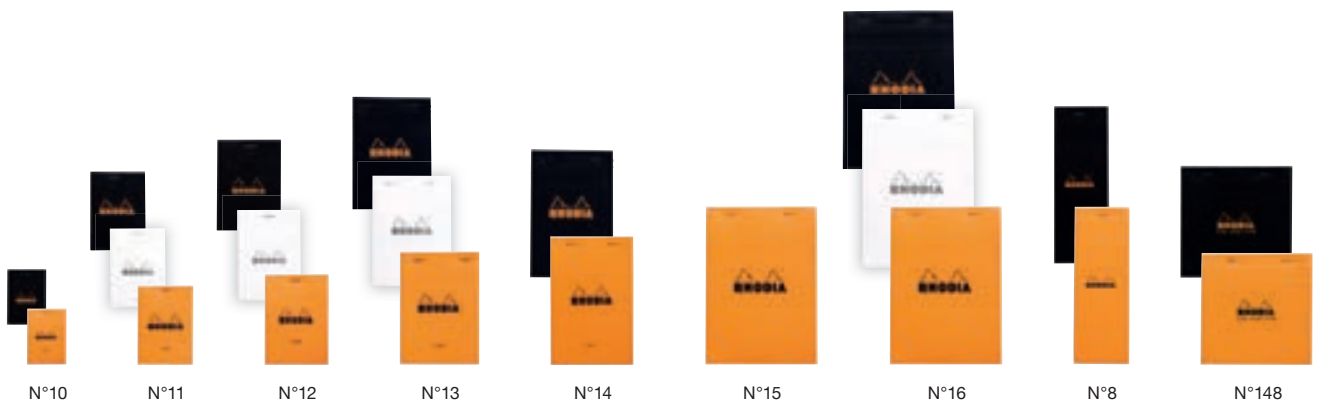

Papier vélin surfin 80 g - Couverture enduite | 80 g superfine vellum paper - Coated cover | 80 g Velinpapier - Beschichteter Umschlag



N°8		N°148	N°210		N°18				N°19						N°20				N°38																							
		carré / square / kariert			A4				A4+						A4+				A3+																							
7,4 X 21		14,8 X 14,8		21 X 21		21 X 29,7				21 x 31,8						21 x 31,8				42 x 31,8																						
2,9 X 8,3		5,8 X 5,8		8,3 X 8,3		8,3 X 11,7				8,3 x 12,5						8,3 x 12,5																										
blanc white weiß		blanc white weiß		blanc white weiß		blanc white weiß				blanc white weiß						jaune yellow gelb		blanc white weiß		jaune yellow gelb		blanc white weiß																				
80 g/m2		80 g/m2			80 g/m2				80 g/m2						80 g/m2				80 g/m2																							
															4 trous																											
5/5	ligné lined liniert	5/5			5/5	L+M	uni blank blan- ko	dot	5/5	L+M	uni blank blan- ko	dot	MEETING	FAX	L+M	5/5	ligné lined liniert	Seyès	L+M	AUDIT	5/5	dot																				
8200C	82009C	8600C	86009C	148200C	148209C	210200C	210209C	18200C	182009C	18201C	18600C	186009C	18601C	18000C	180009C	18558C	18559C	19200C	192009C	19201C	19600C	196009C	19601C	19000C	190009C	19558C	19559C	19400C	194009C	19401C	191000C	19660C	20200C	202009C	119600C	206009C	20100C	201009C	119660C	119700C	38200C	38559C



N°210

N°18

N°19

N°20

N°38



Papier vélin surfon 80 g - Couverture enduite | 80 g superfine vellum paper - Coated cover | 80 g Velinpapier - Beschichteter Umschlag

rhodia basics

Bloc agrafé Orange

Orange head stapled pad

Orange Heftblock

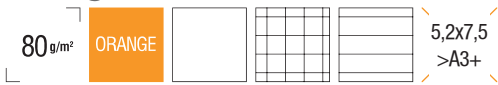

- 80 feuillets détachables microperforés, dessous carton
- 80 detachable microperforated sheets, cardboard backed
- 80 abtrennbare mikroperforierte Blätter, Unterseite aus Karton

N°10 - 5,2 x 7,5	O	5/5	L				
orange		10200C	10600C	20	80	*	
N°11 - A7 - 7,4 x 10,5	O	5/5	L				
orange		11200C	11600C	10	80	*	
N°8 - Shopping 7,4 x 21,0	O	5/5	L				
orange		8200C	8600C	10	40	4800	
N°12 - 8,5 x 12,0	O	5/5	L				
orange		12200C	12600C	10	40	*	
N°13 - A6 - 10,5 x 14,8	O	5/5	L				
orange		13200C	13600C	10	40	4800	
N°14 - 11 x 17	O	5/5	L				
orange		14200C	14600C	10	40	*	
N°148 - Le Carré 14,8 x 14,8	O	5/5	L				
orange		148200C		10	40	3360	
N°15 - A5 - 14,8 x 21	O	5/5	L+M				
Giant Pad Orange (150 feuillets - sheets - Blätter)		15200C	15600C	4	24	2016	
N°16 - A5 - 14,8 x 21	O	5/5	L+M				
orange		16000C	16200C	16600C	10	40	3360
N°210 - Le Carré 21 x 21	O	5/5	L+M				
orange		210200C			5	20	1800
N°18 - A4 - 21 x 29,7	O	5/5	L+M				
orange		18000C	18200C	18600C	5	20	1680
N°19 - A4+ - 21 x 31,8	O	5/5	L+M				
orange		19000C	19200C	19600C	5	20	1680
N°38 - A3+ - 42 x 31,8	O	5/5	L+M				
orange		38200C			5	10	500

* Nous consulter - Consult us - Kontaktieren Sie uns

Existe en coffret p.37 - Essential box available p.37 - Als Set erhältlich S. 37



Agrafes non apparentes au dos
Staples do not appear on back
Heftklammern erscheinen nicht auf der Rückseite

Papier vélin surfin 80 g - Couverture enduite | 80 g superfine vellum paper - Coated cover | 80 g Velinpapier - Beschichteter Umschlag



N°10 N°11 N°12 N°13



N°14 N°15 N°16



N°8 N°148 N°210



N°18 N°19



N°38

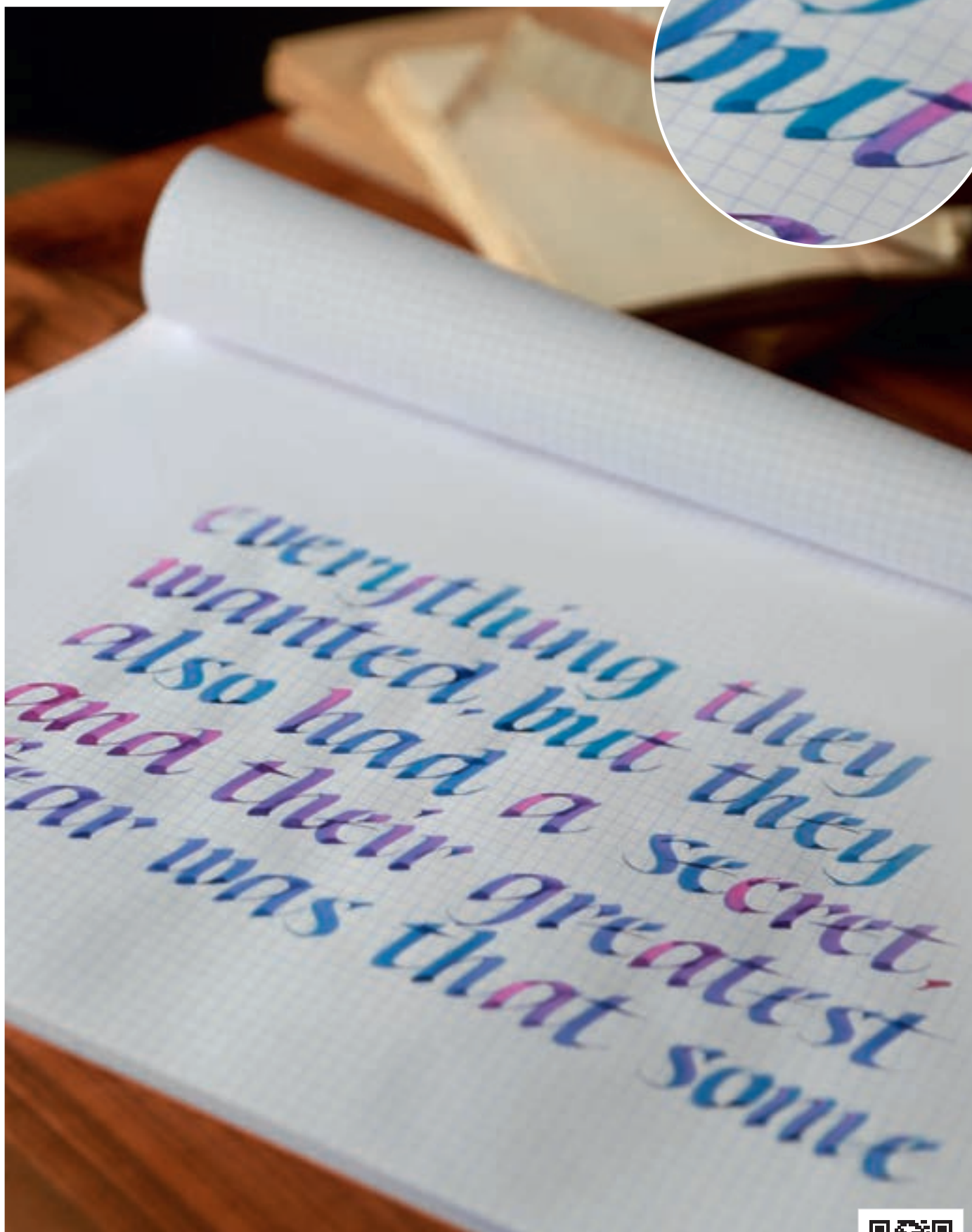

Avec l'aimable autorisation de Hi_Foo. Remerciements chaleureux !
 With the kind permission of Hi_Foo. Warmest thanks!
 Mit freundlicher Genehmigung von Hi_Foo. Herzlichen Dank!



Papier vélin surfin 80 g - Couverture enduite | 80 g superfine vellum paper - Coated cover | 80 g Velinpapier - Beschichteter Umschlag

rhodia basics

Bloc agrafé Black

Black head stapled pad

Schwarzer Heftblock

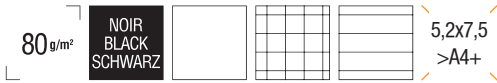

- 80 feuillets détachables microperforés, dessous carton
- 80 detachable microperforated sheets, cardboard backed
- 80 mikroperforierte, abtrennbare Blätter, Unterseite aus Karton

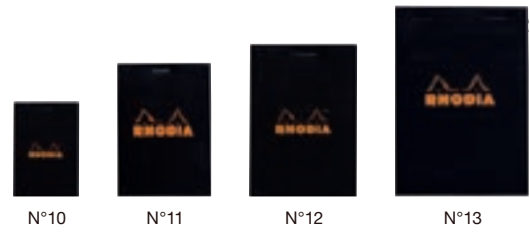

N°10 - 5,2 x 7,5	O	5/5	L			
noir - black - schwarz	102009C	106009C	20	80	11520	
N°11 - A7 - 7,4 x 10,5	O	5/5	L			
noir - black - schwarz	112009C	116009C	10	80	*	
N°8 - Shopping 7,4 x 2,1	O	5/5	L			
noir - black - schwarz	82009C	86009C	10	40	*	
N°12 - 8,5 x 12	O	5/5	L			
noir - black - schwarz	122009C	126009C	10	40	7600	
N°13 - A6 - 10,5 x 14,8	O	5/5	L			
noir - black - schwarz	132009C	136009C	10	40	4800	
N°14 - 11 x 17	O	5/5	L			
noir - black - schwarz	142009C	146009C	10	40	4800	
N°148 - Le Carré 14,8 x 14,8	O	5/5	L			
noir - black - schwarz	148209C		10	40	3360	
N°16 - A5 - 14,8 x 21	O	5/5	L+M			
noir - black - schwarz	160009C	162009C	10	40	3360	
N°210 - Le Carré 21 x 21	O	5/5	L			
noir - black - schwarz	210209C		5	20	1800	
N°18 - A4 - 21 x 29,7	O	5/5	L+M			
noir - black - schwarz	180009C	182009C	5	20	1680	
N°19 - A4+ - 21 x 31,8	O	5/5	L+M			
noir - black - schwarz	190009C	192009C	5	20	1680	



N°8 N°148 N°210



N°18 N°19

* Nous consulter - Consult us - Kontaktieren Sie uns



Agrafes non apparentes au dos
Staples do not appear on back
Heftklammern sind nicht auf der Rückseite zu sehen

Papier vélin surfin 80 g - Couverture enduite | 80 g superfine vellum paper - Coated cover | 80 g Velinpapier - Beschichteter Umschlag



Avec l'aimable autorisation de Hi_Fooo. Remerciements chaleureux !
 With the kind permission of Hi_Fooo. Warmest thanks!
 Mit freundlicher Genehmigung von Hi_Fooo. Herzlicher Dank!



Papier vélin surfin 80 g - Couverture enduite | 80 g superfine vellum paper - Coated cover | 80 g Velinpapier - Beschichteter Umschlag

rhodia basics

Bloc agrafé N°10

N°10 stapled pad

Heftblock Nr. 10



- 80 feuillets détachables microperforés, dessous carton
- 80 detachable microperforated sheets, cardboard backed
- 80 herausnehmbare mikroperforierte Blätter, Unterseite aus Karton

N°10 - 5,2 x 7,5	5/5	L			
orange	10200C	10600C	20	80	*
noir - black - schwarz	102009C	106009C	20	80	11520

* Nous consulter - Consult us - Kontaktieren Sie uns



Présentoir Basics

Basics display

Display Basics

- Boîte présentoir en carton prête-à-vendre
- Sélection de 120 blocs Orange & Black + 75 crayons à papier
- Ready-to-sell cardboard box of 120 selected Orange & Black notepads + 75 pencils
- Verkaufsfertige Display-Kartonbox
- Auswahl von 120 Orange & Schwarz Blöcken + 75 Bleistifte

36 x 46 x 20	5/5	L	
195 produits - products - Produkte	200099PC	200097C	1



Présentoir N°10

N°10 display

Display Nr. 10

- Boîte présentoir en carton prête-à-vendre sélection de 60 blocs Orange & Black
- Ready-to-sell cardboard box of 60 selected Orange & Black notepads
- Orange & Schwarz Verkaufsfertige Display-Kartonbox mit einer Auswahl von 60 Blöcken

17 x 20 x 25	5/5	L	
60 assortis - assorted - assortiert	100002PC	100006PC	60

Papier vélin surfin 80 g - Couverture enduite | 80 g superfine vellum paper - Coated cover | 80 g Velinpapier - Beschichteter Umschlag



Coffret l'Essentiel



Essential box

Set «Essential»



- Contenu du coffret Orange :
1x bloc N°8 + 2x blocs N°11
+ 1x bloc N°16 + 2x crayons à papier
- Orange box includes:
1x N°8 notepad + 2x N°11 notepads
+ 1x N°16 notepad + 2x pencils
- Inhalt des Orange Sets :
1x Block Nr. 8 + 2x Blöcke Nr. 11
+ 1x Block Nr. 16 + 2x Bleistifte

- Contenu du coffret White :
2x blocs N°11 + 1x bloc N°13
+ 1x bloc N°16 + 2x crayons à papier
- White box includes:
2x N°11 notepads + 1x N°13 notepad
+ 1x N°16 notepad + 2x pencils
- Inhalt des Sets White:
2x Blöcke Nr. 11 + 1x Block Nr. 13
+ 1x Block Nr. 16 + 2x Bleistifte

	22,8 x 18 x 3	5/5	L	Mini	
	orange	9200C	9201C	5	1
	blanc - white - weiß	92001C		5	1

Petit nécessaire d'écriture !

L'essentiel selon Rhodia, présenté dans un coffret singulier, parfaite reproduction de l'emblématique bloc agrafé. À offrir ou à s'offrir, parce qu'on adore le réutiliser ou en détourner l'usage à l'envi.

Contient 4 blocs agrafés en 3 formats, accompagnés de 2 crayons à papier.

Writing essentials in a box!

These Rhodia essentials come in a distinctive box that's a perfect replica of the emblematic stapled notepad. Treat yourself or others. Enjoy using it and reusing it to store more Rhodia essentials or something completely different. Contains four stapled notepads in three formats, and two pencils.

Ein kleines Schreibset!

Das Wesentliche im Sinne von Rhodia, präsentiert in einer einzigartigen Schachtel, einer perfekten nachbildung des emblematischen Heftblocks.

Zum Verschenken oder für sich selbst, denn wir lieben es, ihn wiederzuverwenden oder nach Lust und Laune umzufunktionieren.

Enthält 4 Heftblöcke in 3 Formaten und 2 Bleistifte.



1x N°8 + 2x N°11 + 1x N°16 + 2 crayons / 1x Nr. 8 + 2x Nr. 11 + 1x Nr. 16 + 2 Bleistifte



2x N°11 + 1x N°13 + 1x N°16 + 2 crayons / 2x Nr. 11 + 1x Nr. 13 + 1x Nr. 16 + 2 Bleistifte

rhodia basics

Bloc agrafé White

White head stapled pad

Weiß Heftblock

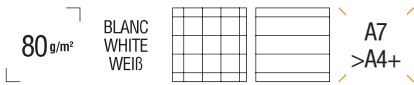

- 80 feuillets détachables microperforés, réglure grise, dessous carton
- 80 detachable microperforated sheets, grey ruling, cardboard backed
- 80 mikroperforierte, abtrennbare Blätter, grau liniert, Unterseite aus Karton

N°11 - A7 - 7,4 x 10,5	5/5	L			
blanc - white - weiß	11201C	11601C	10	80	9600
N°12 - 8,5 x 12	5/5	L			
blanc - white - weiß	12201C	12601C	10	40	*
N°13 - A6 - 10,5 x 14,8	5/5	L			
blanc - white - weiß	13201C	13601C	10	40	*
N°16 - A5 - 14,8 x 21	5/5	L+M			
blanc - white - weiß	16201C	16601C	10	40	3360
N°18 - A4 - 21 x 29,7	5/5	L+M			
blanc - white - weiß	18201C	18601C	5	20	1680
N°19 - A4+ - 21 x 31,8	5/5	L+M			
blanc - white - weiß	19201C	19601C	5	20	1680

* Nous consulter - Consult us - Kontaktieren Sie uns

Existe en coffret p.37 - Essential box available p.37 - Als Set erhältlich S. 37

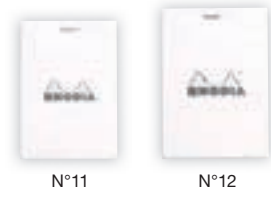

réglure 5/5 grise
5/5 squared grey ruling
grau kariert 5/5

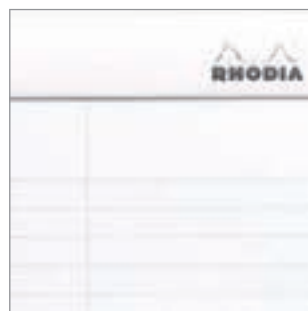

réglure ligné grise
lined grey ruling
grau liniert



logo Rhodia argent
silver Rhodia logo
silbernes Rhodia-Logo



agrafes non apparentes au dos
staples do not appear on back
Heftklammern sind auf der Rückseite
nicht sichtbar



201000PC p.259

Épure absolue en blanc et argent, un clin d'oeil au numérique incarnant à la perfection l'intemporalité du bloc Rhodia. Comme l'affirmation éclatante de l'incroyable modernité du design originel!

An absolutely pure version in white and silver is a nod to the digital universe that also perfectly embodies the timeless qualities of the Rhodia pad. Further dazzling proof of the original design's incredible modernity!

Absolute Reinheit in Weiß und Silber, eine Andeutung an die Digitaltechnik, die die Zeitlosigkeit des Rhodia-Blocks perfekt verkörpert. Als strahlende Bestätigung der unglaublichen Modernität des ursprünglichen Designs!



Papier vélin surfín 80 g - Couverture enduite | 80 g superfine vellum paper - Coated cover | 80 g Velinpapier - Beschichteter Umschlag

rhodia basics

Meeting Pad

Meeting Pad

Meetingblock

80 g/m² **ORANGE** **NOIR BLACK SCHWARZ** **BLANC WHITE WEIß** **DATE NOTES ACTION** **A5 A4+**

- 80 feuillets détachables microperforés, réglure grise, dessous carton
- 80 detachable microperforated sheets, grey ruling, cardboard backed
- 80 mikroperforierte, abtrennbare Blätter, grau liniert, Unterseite aus Karton

N°16 - A5 - 14,8 x 21		MEETING			
	orange	16400C	10	40	3360
	noir - black - schwarz	164009C	10	40	3360
	blanc - white - weiß	16401C	10	40	3360
N°19 - A4+ - 21 x 31,8		MEETING			
	orange	19400C	5	20	1680
	noir - black - schwarz	194009C	5	20	1680
	blanc - white - weiß	19401C	5	20	1680

Meeting Pad, c'est le bloc dédié à la prise de note optimisée ! Pour aller à l'essentiel, les pages sont pré-imprimées et les zones dédiées à chaque information clairement définies graphiquement : date/événement, notes, actions. Grâce aux feuillets détachables, vous disposez d'un compte-rendu prêt à classer ou à transmettre.

Meeting Pad is purposely designed for even more efficient note-taking! Get straight to the point on its pre-printed pages with clearly defined spaces for the date/event, notes and actions. The sheets are detachable so your meeting report is ready to file or pass on.

Meetingblock ist der spezielle Block für das optimierte Notizenmachen!

Um sich auf das Wesentliche zu konzentrieren, sind die Seiten vorgedruckt und die Bereiche, die jeder Information gewidmet sind, grafisch klar definiert: Datum/Ereignis, Notizen, Aktionen. Dank der abtrennbaren Bögen verfügen Sie über ein fertiges Kurzprotokoll, das Sie abheften oder weiterleiten können.



N°16



N°19



Le Carré

The square

Im Quadrat

80 g/m² ORANGE NOIR BLACK SCHWARZ 14,8x14,8 21x21

- 80 feuillets détachables microperforés, dessous carton
- 80 detachable microperforated sheets, cardboard backed
- 80 mikroperforierte, abtrennbare Blätter, Unterseite aus Karton

N°148 - Le Carré - 14,8 x 14,8	5/5			
orange	148200C	10	40	3360
noir - black - schwarz	148209C	10	40	3360
N°210 - Le Carré - 21 x 21	5/5			
orange	210200C	5	20	1800
noir - black - schwarz	210209C	5	20	1800



N°148

N°148



N°210

N°210



Bloc agrafé côté Side

Stapled pad on long side

Seitig gehefteter Block

80 g/m² ORANGE A4+

- Bloc de cours agrafé côté, imprimé recto/verso, 80 feuillets détachables microperforés, perforation 4 trous à 80 mm, dessous carton
- Stapled pad on long side, 80 detachable microperforated sheets, 4 holes punched at 80 mm, cardboard backed
- Seitlich gehefteter Schulblock, beidseitig bedruckt, 80 mikroperforierte, abtrennbare Blätter, 4-fach gelocht im Abstand von 80 mm, Unterseite aus Karton

A4+ - 22,3 x 29,7	Seyès	5/5	L			
A4 détaché - detached - abgetrennt	118015C	118016C	118014C	5	20	1260

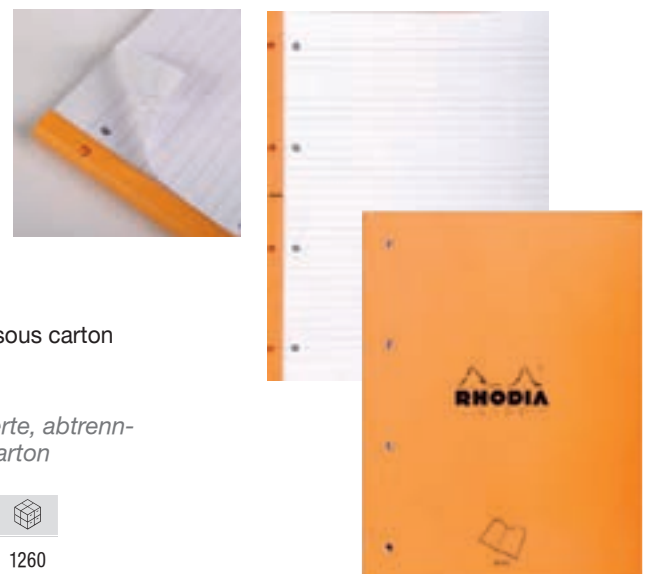

Papier vélin surfine 80 g - Couverture enduite | 80 g superfine vellum paper - Coated cover | 80 g Velinpapier - Beschichteter Umschlag

Photos non contractuelles - Photos are not contractually binding - Bild vertraglich nicht bindend

rhodia basics

Bloc agrafé perforé

Punched stapled pad

Perforierter Heftblock



- 80 feuillets détachables microperforés, perforation 4 trous à 80 mm, dessous carton
- 80 detachable microperforated sheets, 4 holes punched at 80 mm, cardboard backed
- 80 mikroperforierte, abtrennbare Blätter, 4-fach gelocht im Abstand von 80 mm, Unterseite aus Karton



	N°20 - A4+ - 21 x 31,8	Seyès	5/5	L + M			
	A4 détaché - detached - abgetrennt	20100C	20200C	119600C	5	20	1680
	A4 détaché - detached - abgetrennt	201009C	202009C	206009C	5	20	1680



Yellow

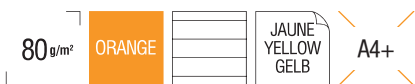

- Bloc américain ou legal pad, 80 feuillets détachables microperforés, perforation 4 trous à 80 mm, dessous carton
- legal pad, 80 detachable microperforated sheets, 4 holes punched at 80 mm, cardboard backed
- Legal Pad, 80 abtrennbare mikroperforierte Blätter, 4-fach gelocht im Abstand von 80 mm, Unterseite aus Karton

	N°119 - A4+ - 21 x 31,8	L + M			
	A4 détaché - detached - abgetrennt	119660C	5	20	1680



Audit



- 80 feuillets détachables microperforés, perforation 4 trous à 80 mm, dessous carton
- 80 detachable microperforated sheets, 4 holes punched at 80 mm, cardboard backed
- 80 mikroperforierte, abtrennbare Blätter, 4-fach gelocht bei 80 mm, Unterseite aus Karton

	N°119 - A4+ - 21 x 31,8	Multicolonnes / Multicolumns			
	A4 détaché - detached - abgetrennt	119700C	5	20	1680



Yellow

80 g/m² ORANGE JAUNE YELLOW GELB A5 A4+

- Bloc américain ou legal pad, 80 feuillets détachables microperforés, dessous carton
- legal pad, 80 detachable microperforated sheets, cardboard backed
- *Legal Pad, 80 mikroperforierte, abtrennbare Blätter, Unterseite aus Karton*

N°16 - A5 - 14,8 x 21	5/5	L			
orange	16260C		10	40	3360
N°19 - A4+ - 21 x 31,8	5/5	L + M			
orange	19660C		5	20	1680



Message

80 g/m² ORANGE PRÉ-IMPRIMÉ PRE-PRINTED VORGEDRUCKT 11x17

- Bloc pour rendez-vous, rappels ou messages téléphoniques, 80 feuillets détachables microperforés, dessous carton
- Pad to log appointments, reminders and telephone messages, 80 detachable microperforated sheets, cardboard backed
- *Block für Termine, Erinnerungshilfen oder Telefonnachrichten, 80 mikroperforierte, abtrennbare Blätter, Unterseite aus Karton*

N°140 - 11 x 17	pré-imprimé / pre-printed / vorgedruckt			
orange	140000C	10	40	4800



Fax

80 g/m² ORANGE PRÉ-IMPRIMÉ PRE-PRINTED VORGEDRUCKT A4+

- Bloc pour transmission de télécopies, 80 feuillets détachables microperforés, dessous carton
- Fax transmission pad, 80 detachable microperforated sheets, cardboard backed
- *Block für die Übertragung von Faxen, 80 mikroperforierte, abtrennbare Blätter, Unterseite aus Karton*

N°191 - A4+ - 21 x 31,8	pré-imprimé / pre-printed / vorgedruckt			
orange	191000C	5	20	1680



Photos non contractuelles - Photos are not contractually binding - Bild vertraglich nicht bindend

rhodia basics

dotPad

dotPad

dotBlock



- 80 feuillets détachables microperforés (non perforés), réglure grise, points espacés de 5 mm, dessous carton
- 80 detachable microperforated sheets (not punched), light grey grid with 5mm intervals between dots, cardboard backed
- 80 mikroperforierte, abtrennbare Blätter (nicht perforiert), grau liniert, Punkte im Abstand von 5 mm, Unterseite aus Karton

	N°12 - 8,5 x 12	dot			
	orange	12558C	10	40	7600
	noir - black - schwarz	12559C	10	40	7600
	N°16 - A5 - 14,8 x 21	dot			
	orange	16558C	10	40	3360
	noir - black - schwarz	16559C	10	40	3360
	N°18 - A4 - 21 x 29,7	dot			
	orange	18558C	5	20	1680
	noir - black - schwarz	18559C	5	20	1680
	N°19 - A4+ - 21 x 31,8	dot			
	orange	19558C	5	20	1680
	noir - black - schwarz	19559C	5	20	1680
	N°38 - A3+ - 42 x 31,8	dot			
	noir - black - schwarz	38559C	5	10	500



Destiné aux professionnels de la création, aux graphistes, aux architectes, aux artistes..., et à tous ceux qui désirent un support discret pour leurs notes, esquisses, tracés, plans, croquis, schémas...

Un bloc agrafé dont la réglure est une grille géométrique composée de points espacés de 5 mm et imprimés tout en finesse sur le fameux papier vélin surfin Clairefontaine 80 g certifié PEFC.

Une alternative aux réglures classiques, pour créer au-delà des lignes et des quadrillages ! Et pour que votre créativité s'exprime sans entrave, cette matrice subtile devient presque imperceptible au scan ou à la photocopie.

A ruling to think beyond lines and squares !

Developed as an original and functional alternative to traditional lines and boxes for creative people, architects, graphic designers...

The Rhodia stapled dotPad has a light grey geometric dot matrix that provides a subtle guide for notes and sketches.

Für kreative Berufe, Grafikdesigner, Architekten, Künstler... und alle, die eine diskrete Unterlage für ihre Notizen, Skizzen, Pläne, Entwürfe, Schemata... wünschen.

Ein Heftblock, dessen Lineatur ein geometrisches Raster ist, bestehend aus Punkten, die in einem Abstand von 5 mm angeordnet sind und auf dem berühmten 80 g Clairefontaine Velinpapier PEFC-zertifiziert fein gedruckt sind.

Eine Alternative zu klassischen Lineaturen, um über Linien und Raster hinaus zu gestalten.

Und damit Sie Ihrer Kreativität freien Lauf lassen können, ist diese subtile Matrix beim Scannen oder Kopieren kaum sichtbar.





Photos non contractuelles - Photos are not contractually binding - Bild vertraglich nicht bindend

rhodia basics

Bloc agrafé Le R

Le R stapled pad

Heftblock R



- Couverture pelliculée soft touch orange et noir recto/verso, 70 feuillets détachables microperforés (non perforés), papier vélin velouté ivoire 90 g, réglure grise, dessous carton
- Ultra-smooth paper sheets encased in a soft-touch coated cover, 70 detachable microperforated (not punched) sheets, 90 g ivory brushed vellum paper, grey ruling, cardboard backed
- Orange und schwarz beidseitig laminiertes Soft-Touch-Einband, 70 mikroperforierte, abtrennbare Blätter (nicht perforiert), 90 g elfenbeinfarbenes Velinpapier, grau liniert, Unterseite aus Karton



N°11

N°12



N°16



N°18

N°11 - A7 - 7,2 x 10,5		L	MINI				
	orange	112011C	10	1	80	12480	
	noir - black - schwarz	112012C	10	1	80	11520	
N°12 - 8,5 x 12		L	MINI				
	orange	122011C	10	1	40	7600	
	noir - black - schwarz	122008C	122012C	10	1	40	7600
N°16 - A5 - 14,8 x 21		O	L	MINI			
	orange	162007C		10	1	40	2880
	noir - black - schwarz	162008C	162012C	10	1	40	3360
N°18 - A4 - 21 x 29,7		L	MINI				
	noir - black - schwarz	182012C	5	1	20	1680	

Filmé individuellement - Individually shrink-wrapped - Einzeln in Folie eingeschweißt



extérieur noir - intérieur orange
black outside - orange inside
außen schwarz - innen orange

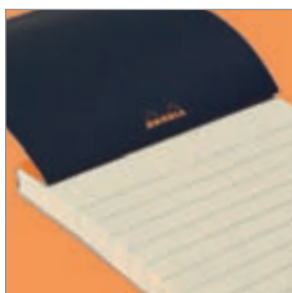

extérieur orange - intérieur noir
orange outside - black inside
außen orange - innen schwarz



Papier vélin velouté ivoire 90 g - Couverture pelliculée | 90 g ivory brushed vellum paper - Coated cover | elfenbeinfarbenes, samtweiches Velinpapier 90 g - Soft-Touch-Einband



Un coeur soyeux dans un écrin de velours, le bloc agrafé version Premium.

Velvety soft on the outside and silky smooth on the inside, the R pad is THE Premium stapled notepad.

Ein seidiges Herz in einer samtweichen Schatulle - der Heftblock in der Premium-Version.



Photos non contractuelles - Photos are not contractually binding - Bild vertraglich nicht bindend

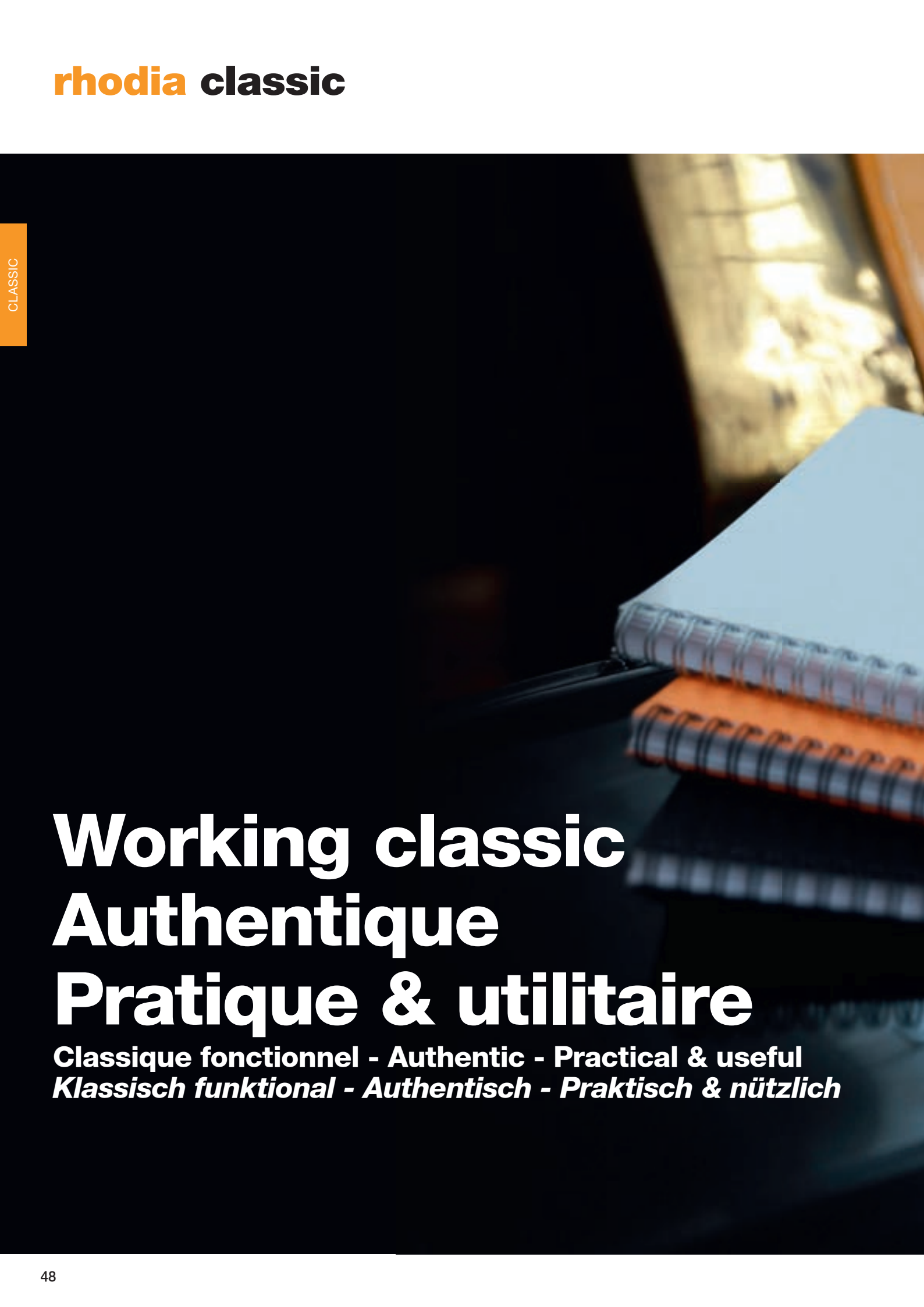

Working classic **Authentique** **Pratique & utilitaire**

Classique fonctionnel - Authentic - Practical & useful

Klassisch funktional - Authentisch - Praktisch & nützlich



rhodia classic

Carnet et cahier piqués

Staplebound notebooks

Geklammerte Notizbücher und Hefte

80 g/m² ORANGE NOIR BLACK SCHWARZ BLANC WHITE WEIß

A7 >A4

- 48 pages non microperforées, réglure grise (White uniquement)
- 24 non microperforated sheets, grey ruling (White only)
- 24 nicht mikroperforierte Blätter, grau liniert (Nur beim weißem)

	A7 - 7,5 x 12	5/5	dot			
	assortis - assorted - assortiert	119152C		20	240	24000
	orange	119158C	119156C	20	240	*
	noir - black - schwarz	119159C	119155C	20	240	24000
	blanc - white - weiß	119151C	119153C	20	240	24000

- 96 pages non microperforées, réglure grise (White uniquement)
- 48 non microperforated sheets, grey ruling (White only)
- 48 nicht mikroperforierte B, grau liniert (Nur beim weißem)

	A5 - 14,8 x 21	5/5	L8	dot			
	assortis - assorted - assortiert	119182C			10	40	4000
	orange	119184C	119188C	119190C	10	40	4000
	noir - black - schwarz	119183C	119189C	119186C	10	40	4000
	blanc - white - weiß	119181C	119187C	119200C	10	40	4000

	A4 - 21 x 29,7	5/5	L8	dot			
	assortis - assorted - assortiert		119165C		10	40	2000
	orange	119164C	119168C	119167C	10	40	2000
	noir - black - schwarz	119163C	119169C	119166C	10	40	2000

* Nous consulter - Consult us - Bitte kontaktieren Sie uns

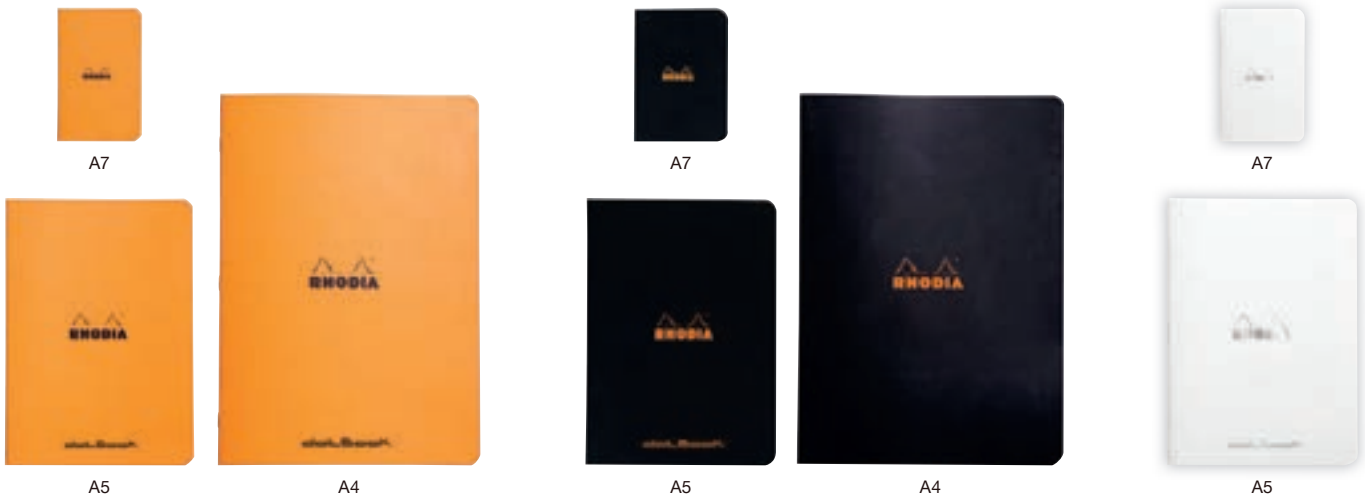

Papier vélin surfin 80 g - Couverture enduite | 80 g superfine vellum paper - Coated cover | 80 g Velinpapier - Beschichteter Umschlag



Notebook

Notebook

Notizbuch

80 g/m² ORANGE NOIR BLACK SCHWARZ BLANC WHITE WEIß



A5+ A4+

- 160 pages détachables microperforées, non perforées, réglure grise (White uniquement)
- 80 unpunched detachable microperforated sheets, grey ruling (White only)
- 80 abtrennbare mikroperforierte Blätter, ungelocht, graue Lineatur (Nur beim weißem)

A5+ - 16 x 21	5/5	L	dot			
assortis - assorted - assortiert	19342C	19346C		5	30	2160
orange	193428C	193468C	193448C	5	30	2160
noir - black - schwarz	193429C	193469C	193439C	5	30	2160
blanc - white - weiß	193421C	193461C	193441C	5	30	2160

- 160 pages détachables microperforées, perforées 4 trous, marge et cadre en-tête
- 80 detachable microperforated sheets, punched with 4 holes, margin and header box
- 80 abtrennbare mikroperforierte Blätter, 4-fach gelocht, Rand und Koprahmen

A4+ - 22,5 x 29,7	5/5 + MC	L + MC				
assortis - assorted - assortiert	19300C	19310C		5	20	1120

- 160 pages détachables microperforées, non perforées, réglure grise (White uniquement), marge et cadre en-tête
- 80 unpunched, detachable microperforated sheets, grey ruling (White only), margin and header box
- 80 abtrennbare mikroperforierte Blätter, ungelocht, graue Lineatur (Nur beim weißem), Rand und Koprahmen

A4+ - 22,5 x 29,7	5/5 + MC	L + MC	dot			
orange	193008C	193108C	193118C	5	20	1120
noir - black - schwarz	193009C	193109C	193039C	5	20	1120
blanc - white - weiß	193001C	193101C		5	20	1120



A5+



A4+

Papier vélin surfine 80 g - Couverture enduite | 80 g superfine vellum paper - Coated cover | 80 g Velinpapier - Beschichteter Umschlag

CLASSIC

Photos non contractuelles - Photos are not contractually binding - Bild verträglich nicht bindend

rhodia classic

Meeting Book

90 g/m² ORANGE NOIR BLACK SCHWARZ BLANC WHITE WEIß DATE NOTES ACTION A5+ A4+

- 160 pages détachables microperforées, pré-imprimées, réglure grise
- 80 detachable microperforated, pre-printed, grey ruling
- 80 abtrennbare mikroperforierte, vorgedruckte Bätter, graue Lineatur

A5+ - 16 x 21	MEETING				
assortis - assorted - assortiert	19341C	5	40	1920	
orange	193418C	5	40	1920	
noir - black - schwarz	193419C	5	40	1920	
Blanc - white - weiß	193411C	5	40	1920	

A4+ - 22,5 x 29,7	MEETING				
orange	193408C	5	20	960	
noir - black - schwarz	193409C	5	20	960	



4 Colors Book

80 g/m² ORANGE NOIR BLACK SCHWARZ 4 COULEURS 4 COLORS 4 FARBEN A4+

- 4 bandes de couleurs = 4 parties distinctes, marge et cadre en-tête
- 4 colors of bands = 4 distinct parts, margin and frame at the top
- 4 Farbbänder = 4 verschiedene Abschnitte, Rand und Kopfrahmen

- 160 pages détachables microperforées, perforées 4 trous
- 80 detachable microperforated sheets, punched with 4 holes
- 80 abtrennbare mikroperforierte Blätter, 4-fach gelocht

A4+ - 22,5 x 29,7	5/5 + MC				
assortis	19320C	5	20	960	

- 160 pages détachables microperforées, non perforées
- 80 unpunched, detachable microperforated sheets
- 80 abtrennbare mikroperforierte Blätter, ungelocht

A4+ - 22,5 x 29,7	L + MC				
orange	193308C	5	20	1120	
noir - schwarz	193309C	5	20	1120	

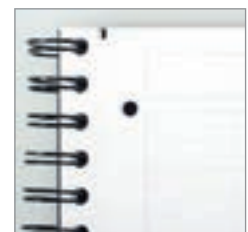
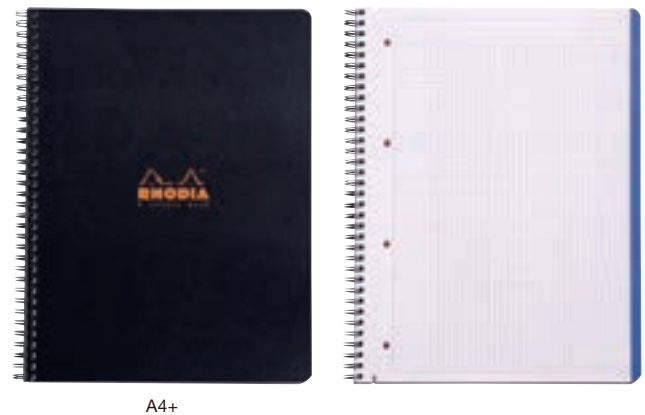

CLASSIC

Reverse Book



- 160 pages détachables microperforées
- 80 detachable microperforated sheets
- 80 abtrennbare mikroperforierte Blätter

	21 x 21	5/5	dot			
	assortis - assorted - assortiert	19360C		5	20	2100
	orange	193608C	193638C	5	20	2100
	noir - black - schwarz	193609C	193639C	5	20	2100



21x21 cm

Notepad

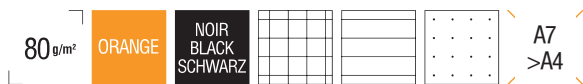

- 80 feuillets détachables microperforés, sole cartonnée ultra-rigide permettant la prise de notes... même sans appui!
- 80 detachable microperforated sheets, ultra rigid board base, to take notes... without additional support!
- 80 abtrennbare, mikroperforierte Blätter, stabile Sohle aus Karton, die das Notizenmachen ermöglicht... auch ohne Abstützen!

	A7 - 7,5 x 10,5	5/5		dot			
	orange	11500C		11503C	10	200	*
	noir - black - schwarz	115009C		115039C	10	200	*
	A6 - 10,5 x 14,8	5/5	L8	dot			
	orange	13500C		13503C	5	60	*
	noir - black - schwarz	135009C		135039C	5	60	3600
	A5 - 14,8 x 21	5/5	L8	dot			
	orange	16500C	16501C	16503C	5	30	2400
	noir - black - schwarz	165009C	165019C	165039C	5	30	2400
	A4 - 21 x 29,7	5/5	L8	dot			
	orange	18500C	18501C	18503C	5	25	1250
	noir - black - schwarz	185009C	185019C	185039C	5	25	1250

* Nous consulter - Consult us - Bitte kontaktieren Sie uns

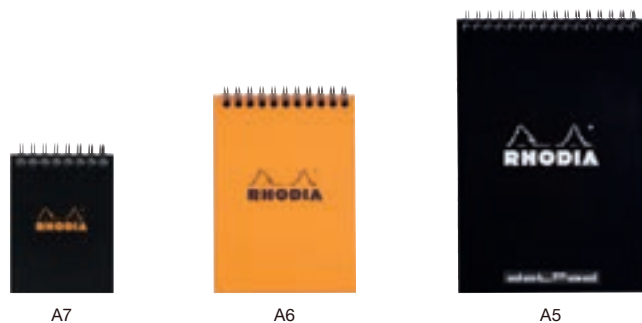

A7

A6

A5



A4

A4

Papier vélin surfon 80 g - Couverture enduite | 80 g superfine vellum paper - Coated cover | 80 g Velinpapier - Beschichteter Umschlag

rhodia classic

Composition book

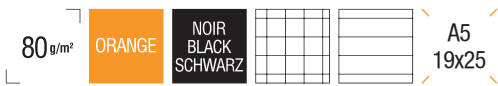

- Brochure cousue dos carré toilé noir, 160 pages non microperforées, réglure grise, disponible en ligné 7 mm avec marge à 3 cm et en 5/5, pages de garde orange, parfaite ouverture à plat
- Canvas-backed threadbound notebook, 80 non microperforated sheets, grey ruling, available in college ruled lined 9/32 inches (7 mm) with 11/4 inches (3 mm) margin and in 5 x 5 squared, orange front and back pages, perfect flat opening
- Fadengebundenes Notizbuch mit schwarzem Leinenrücken, 80 Blätter nicht mikroperforiert, grau liniert, erhältlich in liniert 7 mm mit 3 cm Rand und 5/5, orangefarbene Deckblätter, perfekt flach aufklappbar



A5

19x25 cm / B5

	A5	5/5	L7+M			
	orange	119208C	119218C	5	30	2100
	noir - black - schwarz	119209C	119219C	5	30	2100

	19x25 / B5	5/5	L7+M			
	orange	119228C	119248C	5	15	1575
	noir - black - schwarz	119229C	119249C	5	15	1575



On appelle Composition book le cahier de notes relié couramment utilisé par les écrivains et les étudiants aux USA, parce que réputé plus solide et durable. L'original a une couverture marbrée de noir et blanc portant une étiquette générique sur le recto. La réglure est traditionnellement un ligné 7 mm avec une marge gauche à 3 cm. En lui conférant une allure incomparable en Orange & Black, Rhodia réinterprète ce grand classique en deux formats de brochures cousues à dos toilé, dotées d'élégantes réglures grises.

The Composition book is a type of clothbound notebook commonly used by writers and students in the USA because it is durable and dependable. The original has a marble black and white cover with a label on the front, and the paper is traditionally available college ruled, with horizontal lines at 9/32" intervals and a vertical margin at 1/4 from the left of the page. By giving it the incomparable orange and black look, Rhodia reinterprets the great classic in two canvas-backed clothbound notebooks with elegant grey rulings.

Das Composition Book ist eine Art leinengebundenes Notizbuch, das in den USA üblicherweise von Schriftstellern und Studenten verwendet wird, weil es als robuster und haltbarer erachtet wird. Das Original hat einen schwarz-weiß marmorierten Umschlag mit einem generischen Etikett auf der Vorderseite. Die Linierung ist traditionell eine 7-mm-Linierung mit einem linken Rand bei 3 cm. Durch die Verleihung eines unvergleichlichen Aussehens in Orange & Black, interpretiert Rhodia diesen Klassiker in zwei verschiedenen Formaten: Fadengebundenes Notizbuch mit einer geleimten Rückseite und mit eleganten grauen Lineaturen versehen.





Photos non contractuelles - Photos are not contractually binding - Bild vertraglich nicht bindend

Papier vélin surfin 80 g - Couverture enduite | 80 g superfine vellum paper - Coated cover | 80 g Velinpapier - Beschichteter Umschlag

rhodia classic

Carnet à élastique Unlimited

Unlimited notebook

Notizblock mit Gummizug Unlimited

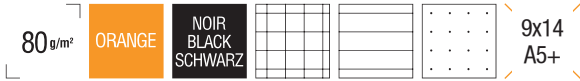

- Couverture pelliculée soft touch 120 pages microperforées, fermeture élastique, réglure grise
- *Soft touch coated cover with elastic closure, 60 microperforated sheets, grey ruling*
- Laminiertes weicher Umschlag 60 mikroperforierte Blätter, Gummizugverschluss, graue Lineatur

	9 x 14	5/5 + C	L + C	dot	
	assortis - assorted - assortiert	118058C	118059C		20*
	orange	118858C	118558C		20*
	noir - black - schwarz	118958C	118559C		20*

* Présentoir de 20 carnets
* 20 notebooks display
* Display mit 20 Notizblöcken

** paquet de 10 carnets sous film
** 10 notebooks shrink-wrapped pack
** Packung mit 10 folienverschweißten Notizbüchern

	A5+ - 16 X 21	5/5 + C	L + C	dot	
	orange	118758C	118978C	118968C	5
	noir - black - schwarz	118759C	118979C	118969C	5



9x14 cm



A5+



*Présentoir carton de 20 carnets (seulement format 9x14 cm)

*20 notebooks display (only 9x14 cm format)

*Karton-Display mit 20 Notizbüchern (nur im Format 9x14 cm)

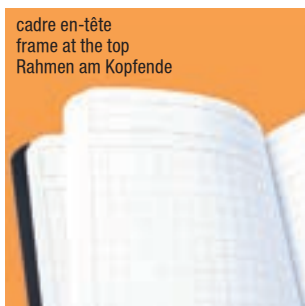

cadre en-tête
frame at the top
Rahmen am Kopfe



pages microperforées
microperforated
sheets
mikroperforierte Blätter



fermeture à élastique bicolore
two-colored elastic closure
zweifarbiger Gummizugverschluss



dos carré collé
glued spine
geklebte Rückseite



extérieur orange
intérieur noir
orange outside
black inside
außen orange
innen schwarz



extérieur noir
intérieur orange
black outside
orange inside
außen orange
innen schwarz

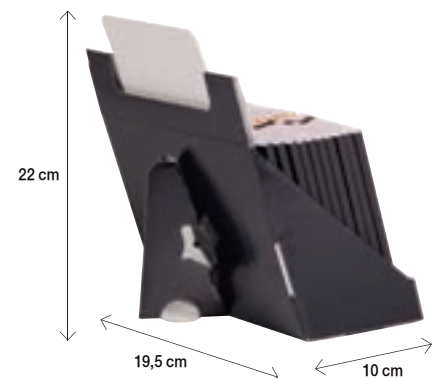



Photos non contractuelles - Photos are not contractually binding - Bild vertraglich nicht bindend

Papier vélin surfin 80 g - Couverture enduite | 80 g superfine vellum paper - Coated cover | 80 g Velinpapier - Beschichteter Umschlag

rhodia classic

Bloc Pocket

Pocket Pad

Taschenblock

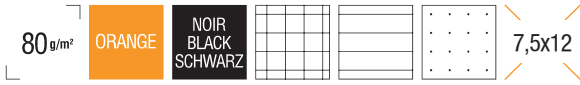

- 40 feuillets détachables microperforés, dessous carton
- 40 detachable microperforated sheets, cardboard backed
- 40 abtrennbare mikroperforierte Blätter, mit Kartonrücken

	7,5 x 12 mm	5/5	L	dot		
	orange	8228C	8680C	8558C	10 *	40
	noir - black - schwarz	8229C	8669C	8559C	10 *	40

- * paquet de 10 blocs sous film
- * 10 notepads shrink-wrapped pack
- * 10 Blöcke mit Zellofanfilm



	7,5 x 12 mm	5/5	L	dot	
	assortis - assorted - assortiert	8220C	8650C	8550C	20 **



- ** Livré en présentoir carton de 20
- ** Delivered in a 20 pieces display
- ** Geliefert im 20er Display

Léger comme une plume ! Un petit bloc passe-partout avec sa couverture typiquement Rhodia en carte enduite orange ou noire.
Un format optimisé pour se glisser dans les poches des hommes et les sacs des femmes.

Put the Rhodia Pocket in your pocket, it's light as a feather!
An all-purpose pad with its iconic Rhodia coated cover to fit men's pockets or women's handbags.

So leicht wie eine Feder! Ein kleiner Taschenblock mit seinem typischen Rhodia-Einband aus beschichtetem Karton orange oder schwarz.
Ein optimiertes Format für die Hosentasche des Mannes und die Handtasche jeder Frau.



Livrés en présentoir carton de 30
 Delivered in a 30 pieces display
 Im 30er Karton-Display geliefert



CLASSIC



Tournez la page, écrivez ou cliquez !
 Turn the page, write or click on!
 Blättern Sie um, schreiben oder klicken Sie darauf!

Tapis de souris Clic Bloc

Clic Bloc mouse pad

Mauspad Clic Bloc



- 30 feuillets encollés, dessous antidérapant
- 30 sheets glued, nonskid backing
- 30 geleimte Blätter, rutschfeste Unterseite

	19 x 23	5/5	
	orange	19410C	30

Papier vélin surfon 80 g - Couverture enduite | 80 g superfine vellum paper - Coated cover | 80 g Velinpapier - Beschichteter Umschlag

Photos non contractuelles - Photos are not contractually binding - Bild vertraglich nicht bindend



Classement Organisation Protection

Filing - Organization - Protection
Ablage - Organisation - Schutz



FILING

Photos non contractuelles - Photos are not contractually binding - Bild vertraglich nicht bindend

rhodia filing

Chemise à élastiques 3 rabats

3-flap elasticated folder

Mappe mit Gummizug und 3 Klappen



- Carte enduite orange ou noire 400 g/m², logo Rhodia sérigraphié, double fermeture à élastique orange ou noir, 4 œillets noirs de maintien
- 400 gsm orange or black coated cardboard, printed Rhodia logo, two elastic closures, 4 black eyelets
- Orange oder schwarz beschichteter Karton 400 g/m², Rhodia-Logo im Siebdruckverfahren aufgedruckt, Doppelter Gummizugverschluss in orange oder schwarz, 4 schwarze Halteösen

12 x 16		📦	📦
	orange	12168C	25* 25
	noir - black - schwarz	12169C	25* 25
19 x 24		📦	📦
	orange	19248C	5 50
	noir - black - schwarz	19249C	5 50
24 x 32		📦	📦
	orange	24328C	5 50
	noir - black - schwarz	24329C	5 50

- * Livré en présentoir carton de 25
- * Delivered in a 25 pieces display
- * Geliefert in einem Display mit 25 Stück



12x16 cm



19x24 cm

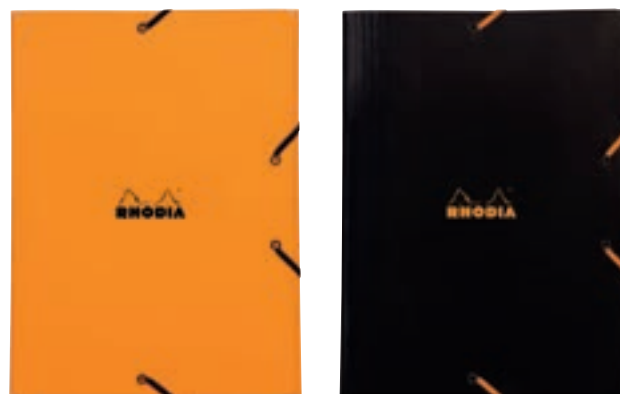

24x32 cm



Résistante et imperméable
 Hardwearing and water-resistant
 Strapazierfähig und wasserfest
 Carte enduite 400 g/m²
 400 g/m² coated cardboard
 Beschichteter Karton 400 g/m²

Documents et petits papiers rhodiatement bien protégés !

Documents notes and papers 'rhodiably' well protected!

Dokumente und kleine Papiere sind Rhodiateuflich gut geschützt!



Photos non contractuelles - Photos are not contractually binding - Bild vertraglich nicht bindend



Professionnel Ergonomique Chic & contemporain

Business - Ergonomic - Stylish & modern

Business - Ergonomisch - Stilvoll & modern



Exabook

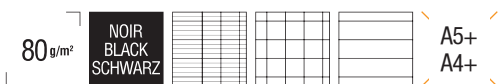

- 160 pages microperforées, perforées 4 trous (A4+) / 6 trous (A5+), 5 intercalaires translucides repositionnables avec pochettes de rangement, 1 règle repositionnable, barrettes amovibles pour positionner la recharge, pochettes pour CD-DVD et cartes de visites
- 80 microperforated & 4 holes punched sheets (A4+) / 6 holes (A5+), 5 removable dividers including pockets for storing documents, repositionable ruler, removable slides, CD-DVD and namecards pockets
- 80 mikroperforierte Blätter, 4-fach gelocht (A4+) / 6-fach gelocht (A5+), 5 durchsichtige, wiedereinstzbare Trennblätter mit Einstecktaschen, 1 wiedereinstzbares Lineal, herausnehmbare Stege zum Positionieren der Nachfüllpackung, Fächer für CD-DVDs und Visitenkarten



A5+

Dimensions totales - Sizes - Gesamte Masse:

A4+ : 25,5 cm x 30,6 cm

A5+ : 19 cm x 22 cm

	5/5 + C	L8 + C			
A5+ 16 x 21	132572C	132576C	6	24	
	Seyès + MC	5/5 + MC	L8 + MC		
A4+ 22,5 x 29,7	132151C	132142C	132146C	-	6

LE cahier d'organisation RECHARGEABLE avec couverture en polypro recyclé à fermeture élastique.

The REFILLABLE organizer with recycled polypro cover and elastic closure.

Der WIEDERAUFFÜLBARE Planer mit einem Einband aus recyceltem Polypro und Gummizugverschluss.

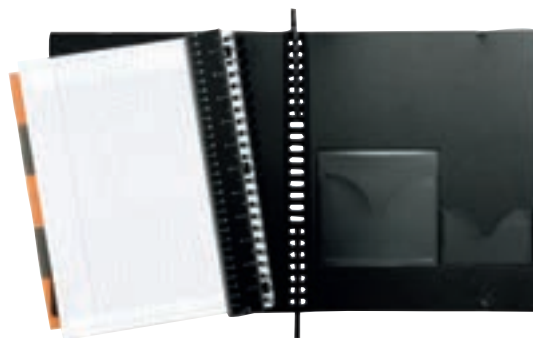

Cahier recharge Exabook

Exabook refill

Exabook-Nachfüllheft



- 160 pages microperforées, perforées 4 trous (A4+) / 6 trous (A5+)
- 80 microperforated & 4 holes punched sheets (A4+) / 6 holes (A5+)
- 80 mikroperforierte & 4-fach gelochte Blätter (A4+) / 6 Löcher (A5+)

	5/5 + C	L8 + C			
A5+ 16 x 21	133572C	133576C	5	30	
	Seyès + MC	5/5 + MC	L8 + MC		
A4+ 22,5 x 29,7	133151C	133142C	133146C	5	20



A5+



A4+

Exameeting



- 160 pages microperforées et pré-imprimées, 5 intercalaires translucides repositionnables avec pochettes de rangement, 1 règle repositionnable, barrettes amovibles pour positionner la recharge, pochettes pour CD-DVD et cartes de visites
- 80 microperforated & pre-printed sheets, 5 removable dividers including pockets for storing documents, repositionable ruler, removable slides, CD-DVD and namecards pockets
- 80 mikroperforierte und vorgedruckte Blätter, 5 durchsichtige, wiederverwendbare Trennblätter mit Einstecktaschen, 1 wiederverwendbares Lineal, herausnehmbare Stege zum Positionieren der Nachfüllpackung, Fächer für CD-DVD und Visitenkarten

Dimensions totales - Sizes - Gesamte Masse
 A4+ : 25,5 cm x 30,6 cm

MEETING			
A4+ 22,5 x 29,7	132401C	-	6



A4+



RHODIACTIVE



Photos non contractuelles - Photos are not contractually binding - Bild vertraglich nicht bindend

GREENBOOK

cahier éco-responsable 100 % recyclé/recyclable

Eco-responsible notebook 100 % recycled/recyclable

Ökofreundliches Notizbuch 100 % recycelt/wiederverwertbar

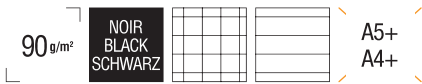

- Couverture en polypropylène 100 % recyclée et recyclable, 160 pages microperforées et perforées (A4+ : perforation 4 trous / A5+ : perforation universelle 6 trous)
- Polypropylene cover 100 % recycled and recyclable, 160 micro-perforated pages punched (A4+: 4-hole punched / A5+: universal 6-hole punched)
- Umschlag aus 100 % recyceltem und wiederverwertbarem Polypropylen, 160 mikroperforierte und perforierte Blätter (A4+: 4 Löcher / A5+: 6 Löcher - Universallochung)

	5/5 + C	L8 + C		
A5+ 16 x 21	119913C	119915C	5	40
	5/5 + MC	L8 + MC		
A4+ 22,5 x 29,7	119912C	119914C	5	20

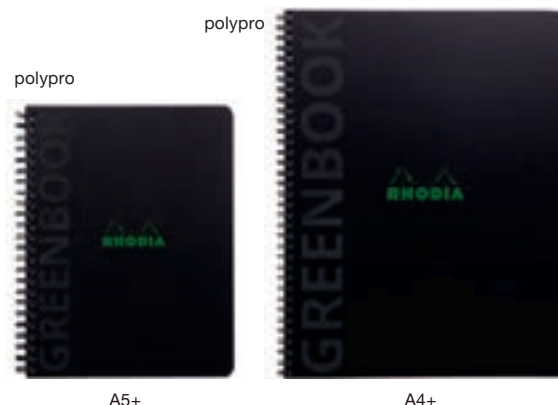
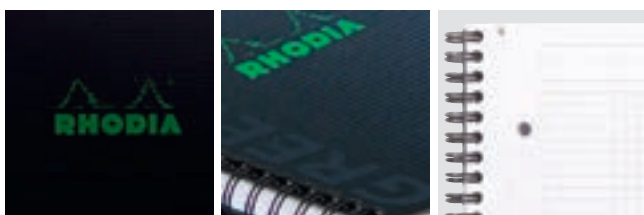

Papier Clairefontaine 90 g/m² 100% recyclé
 À l'opacité élevée et la blancheur naturelle supérieure
 Produit sans désencrage ni traitement au chlore
 Certification FSC recyclé

Clairefontaine 90 gsm paper 100% recycled
 High opacity and superior natural whiteness
 No de-inking or chlorine treatment
 FSC recycled certification

Clairefontaine 90 g/m² Papier aus 100 % Recyclingpapier
 Mit hoher Opazität und überlegener natürlicher Weiße
 Ohne Entfärben oder Chlorbehandlung hergestellt
 FSC-Zertifizierung recycelt



La marque de la gestion forestière responsable
 FSC® C002321



Le Greenbook coche toutes les cases : beau, fonctionnel ET 100 % recyclé et recyclable.

Au bureau ou « on the go »*, optez pour un cahier professionnel éco-responsable.

Sous l'élégante sobriété de sa robe noire en polypro recyclé orné de vert, prenez vos notes sur le remarquable papier recyclé Clairefontaine 90 g/m², à l'opacité élevée et la blancheur naturelle supérieure.

* en déplacement

The Greenbook ticks all the boxes: beautiful, functional AND 100% recycled and recyclable.

At the office or «on the go», choose a professional eco-responsible notebook.

Under the elegant and clean design of its black recycled polypropylene cover branded in green, take your notes on the remarkable Clairefontaine 90 g/m² recycled paper, with its high opacity and superior natural whiteness.

Das Greenbook erfüllt alle Kriterien: schön, funktional UND zu 100 % recycelt und wiederverwertbar.

Ob im Büro oder «on the go», entscheiden Sie sich für ein umweltfreundliches professionelles Notizbuch.*

Unter der eleganten Schlichtheit seines schwarzen Gewandes aus recyceltem Polypro mit grünen Ornamenten machen Sie Ihre Notizen auf dem herausragenden Clairefontaine 90 g/m² Recyclingpapier mit hoher Opazität und überlegener natürlicher Weiße.

* unterwegs



Photos non contractuelles - Photos are not contractually binding - Bild vertraglich nicht bindend

Notepad

Notepad

Notizblock

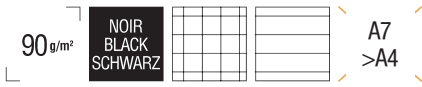

- Couverture en polypropylène 100% recyclée et recyclable, 80 feuillets microperforés, 1 pochette carton pour ranger des documents (uniquement format A4)
- Polypropylene cover 100% recycled and recyclable, 80 microperforated sheets, 1 pocket for storing documents (only for A4)
- Umschlag aus 100 % recyceltem und recycelbarem Polypropylen, 80 mikroperforierte Blätter, 1 Innentasche zum Aufbewahren von Dokumenten. (nur A4-Format)



A7

A6

A5

polypro



A4

	5/5	L			
A7 - 7,5 x 10,5	11920C		10	160	8000
A6 - 10,5 x 14,8	13920C		5	60	3000
A5 - 14,8 x 21	16920C	16921C	5	30	2100
A4 - 21 x 29,7	19920C		5	20	1000

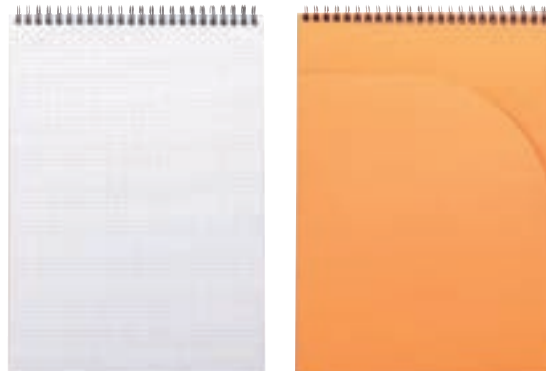

Notebook

Notebook
Notizbuch

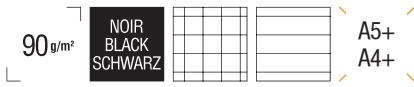

- Couverture en polypropylène 100% recyclée et recyclable, 160 pages microperforées, perforation universelle 9 trous (A4+) / 6 trous (A5+), règle repositionnable, 6 marque-pages numérotés
- Polypropylene cover 100% recycled and recyclable, 80 microperforated sheets, universal punched 9 holes (A4+) / 6 holes (A5+), removable ruler, 6 numbered bookmarks
- Umschlag aus 100 % recyceltem und recycelbarem Polypropylen, mikroperforierte 80 Blätter, 9-fache (A4+) / 6-fache (A5+) Universallochung, wiederverwendbares Lineal, 6 bezifferte Lesezeichen

	5/5 + C	L8 + C		
A5+ 16 x 21	119910C	119911C	5	40
	5/5 + MC	L8 + MC		
A4+ 22,5 x 29,7	119900C	119901C	5	20



polypro



A5+

polypro



A4+

Meeting Book



- Couverture en polypropylène 100% recyclée et recyclable, 160 pages microperforées, règle grise
- Polypropylene cover 100% recycled and recyclable, 80 microperforated sheets, grey ruling
- Umschlag aus 100 % recyceltem und recycelbarem Polypropylen, 80 mikroperforierte Blätter, graue Lineatur

	MEETING		
A5+ 16 x 21	119941C	5	40
A4+ 22,5 x 29,7	119940C	5	20



polypro



A4+

polypro



A5+



Photos non contractuelles - Photos are not contractually binding - Bild vertraglich nicht bindend

Pro Book

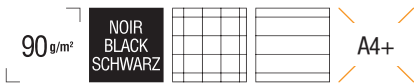

- Couverture en polypropylène 100% recyclée et recyclable, 160 pages microperforées et perforées 4 trous, 5 intercalaires translucides repositionnables avec pochettes de rangement, fermeture par élastique plat bicolore
- Polypropylene cover 100% recycled and recyclable, 80 micro-perforated & 4 holes punched sheets, 5 removable dividers including pockets for storing documents, secured by elastic
- Umschlag aus 100 % recyceltem und recycelbarem Polypropylen, 80 mikroperforierte und 4-fach gelochte Blätter, 5 durchsichtige, wiedereinsetzbare Trennblätter mit Einsteckfächern und zweifarbigem Gummizugverschluss

polypro



A4+

	5/5 + MC	L + MC		
A4+ - 22,5 x 29,7	119930C	119931C	5	20

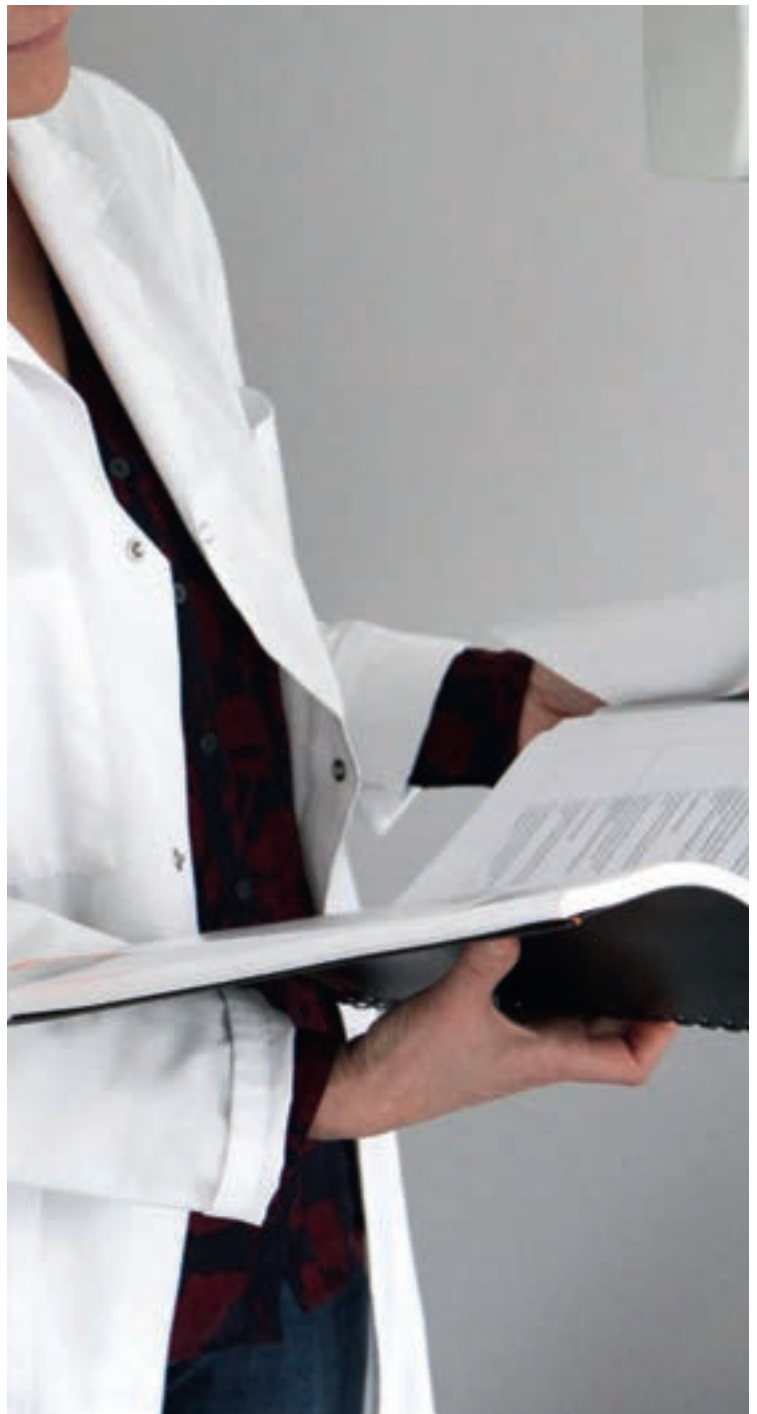

Reverse Book

Reverse Book

Wendbares Buch

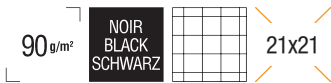

- Couverture en polypropylène 100% recyclée et recyclable, 160 pages microperforées
- Polypropylene cover 100% recycled and recyclable, 80 microperforated sheet
- Umschlag aus 100 % recyceltem und recycelbarem Polypropylen, 80 mikroperforierte Blätter

	5/5		
21 x 21	119960C	5	20

polypro



4 Colors Book

4 Colors Book

4-Farbenbuch

90 g/m² NOIR BLACK SCHWARZ 4 COULEURS 4 COLORS 4 FARBEN A4+

- Couverture en polypropylène 100% recyclée et recyclable, 160 pages microperforées et perforées 4 trous, 3 intercalaires translucides repositionnables, avec pochettes de rangement, 4 bandes de couleurs = 4 parties distinctes
- Polypropylene cover 100% recycled and recyclable, 80 microperforated & 4 holes punched sheets, 3 removable dividers including pockets for storing documents, 4 colours of bands = 4 distinct parts
- Umschlag aus 100 % recyceltem und recycelbarem Polypropylen, 80 mikroperforierte und 4-fach gelochte Blätter, 3 durchsichtige Trennblätter mit Einstecktaschen, 4 Farbstreifen = 4 verschiedene Abschnitte

	5/5 + MC		
A4+ 22,5 x 29,7	119920C*	5	20



* jusqu'à épuisement des stocks - while stocks last - solange der Vorrat reicht



polypro



A4+

Address Book

Address Book

Adressbuch

90 g/m² NOIR BLACK SCHWARZ PRÉ-IMPRIMÉ PRE-PRINTED VORGEDRUCKT A5

- Couverture en polypropylène 100% recyclée et recyclable, 160 pages non microperforées, onglets vernis, 1 pochette cartonnée pour ranger des documents
- Polypropylene cover 100% recycled and recyclable, varnished A-Z tabs for strength and cleanliness, 1 pocket for storing documents
- Umschlag aus 100 % recyceltem und recycelbarem Polypropylen, 80 nicht mikroperforierte Bögen, Lackierte Register, 1 Kartonhülle zur Aufbewahrung von Dokumenten

A5 - 14,8 x 21	119970C	5	40

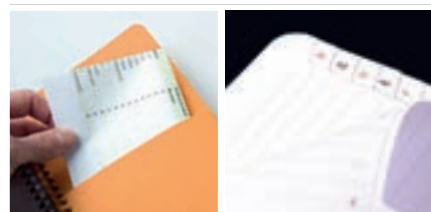

polypro



A5



Papier vélin velouté 90 g - Couverture polypro | 90 g brushed vellum paper - Polypro cover | 90 g Velinpapier- Deckel aus Polypro

RHODIACTIVE

Photos non contractuelles - Photos are not contractually binding - Bild vertraglich nicht bindend

rhodiaactive

Notebook rembordé semi-rigide

Softback wirebound notebook

Notizbuch mit halbfestem Umschlag

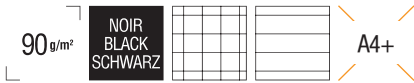

- 160 pages microperforées, perforation universelle 9 trous, règle repositionnable, 6 marque-pages numérotés
- 80 microperforated & 9 holes universal multi-punched sheets, removable ruler and 6 numbered bookmarks
- 80 mikroperforierte & 9-fach gelochte, universelle Blätter, herausnehmbares Lineal und 6 bezifferte Lesezeichen



A4+

	5/5	L		
A4+ - 22,5 x 29,7	191301C	191310C	5	20



Papier vélin velouté 90 g - Couverture polypro | 90 g brushed vellum paper - Polypro cover | 90 g Velinpapier- Deckel aus Polypro

Brochure rembourée semi-rigide

Softback casebound notebook

Notizbuch mit halbfestem Umschlag

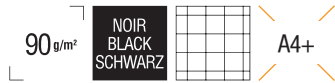

- Dos carré collé, 160 pages microperforées et non perforées, ruban marque-page noir, calendrier perpétuel et informations utiles (fuseaux horaires,...)
- Glued spine, 80 microperforated unpunched sheets, black ribbon bookmark, date planner and other useful information
- *Geklebte Rückseite, 80 mikroperforierte und nicht perforierte Blätter, schwarzes Lesezeichenband, ewiger Kalender und nützliche Informationen (Zeitzonen,...)*



A4+

	5/5 + C		
A4+ - 22,5 x 29,7	190401C	5	25

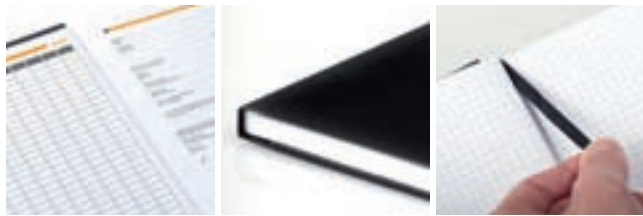

Brochure rembourée rigide

Hardback casebound

Notizbuch mit halbfestem Umschlag

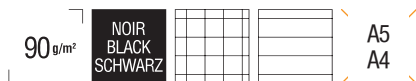

- 192 pages non perforées et non microperforées, ruban marque-page noir, calendrier perpétuel et informations utiles (fuseaux horaires,...), coins prédécoupés pour retrouver la dernière page utilisée
- 96 unpunched and not detachable sheets, black ribbon bookmark, date planner and other useful information, microperforated bottom corners
- *96 nicht perforierte und nicht mikroperforierte Blätter, schwarzes Lesezeichenband, ewiger Kalender und nützliche Informationen (Zeitzonen,...), vorgestanzte Ecken, um die zuletzt benutzte Seite wiederzufinden*

	5/5 + C	L + C		
A5 - 14,8 x 21	-	19526C	5	20
A4 - 21 x 29,7	19052C	19056C	5	15



RHODIACTIVE



A5

A4

PP Notebook

PP Notebook



Notizbuch PP



- Couverture en polypropylène 100% recyclée et recyclable, 180 pages microperforées, perforation universelle 9 trous (A4+) / 6 trous (A5+), 3 intercalaires translucides repositionnables, fermeture à élastique

- Polypropylene cover 100% recycled and recyclable, 90 microperforated sheets, universal punched 9 holes (A4+) / 6 holes (A5+), 3 removable PP dividers, elastic closure

- Umschlag aus 100 % recyceltem und recycelbarem Polypropylen, 90 mikroperforierte Blätter, 9-fache (A4+) / 6-fache (A5+) Universallochung, 3 durchsichtige, wiedereinsetzbare Trennblätter, Gummizugverschluss

	L8 + MC		
A5+ 16 x 21	119237C	3	30
A4+ 22,5 x 29,7	119236C	3	24





Meeting Book rembourré rigide

Hardback wirebound Meeting Book

Meeting Book mit festem Umschlag



- 160 pages microperforées, pré-imprimées
- 80 microperforated, pre-printed sheets
- 80 mikroperforierte, vorgedruckte Blätter

	MEETING		
A4+ 22,5 x 29,7	119238C	3	21



A4+

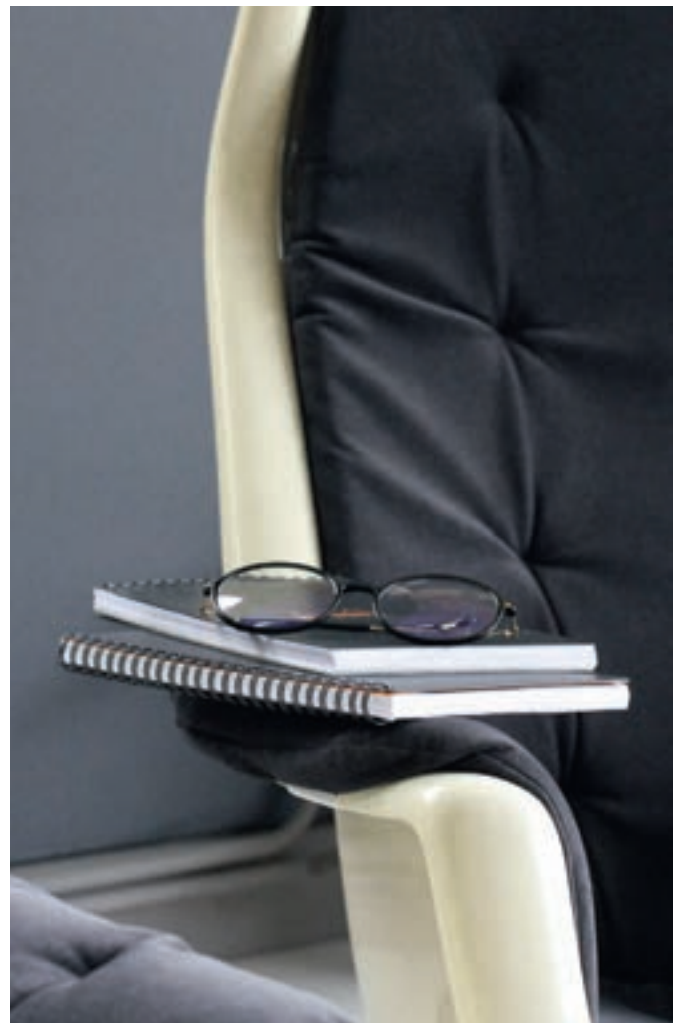

Notebook rembouré rigide

Hardback wirebound notebook

Notizbuch mit festem Umschlag



- 160 pages microperforées, calendrier perpétuel, infos utiles
- 80 microperforated sheets, date planner and other useful informations
- 80 mikroperforierte Blätter, Terminplaner und andere nützliche Informationen

	L8 + MC		
A5 - 14,8 x 21	119233C	3	30
A4 - 21 x 29,7	119232C	3	18



A4

A5



RHODIACTIVE

Brochure rembourée rigide

Hardback casebound notebook

Fester Broschüre-Umschlag

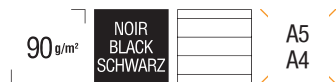

- 192 pages non perforées et non microperforées, ruban marque-page noir, calendrier perpétuel et informations utiles (fuseaux horaires,...), coins prédécoupés pour retrouver la dernière page utilisée
- 96 unpunched and non microperforated sheets, black ribbon bookmark, date planner and other useful information, microperforated bottom corners
- 96 Blätter, nicht perforiert und nicht mikroperforiert, schwarzes Lesezeichenband, ewiger Kalender und nützliche Informationen (Zeitzone,...), vorgestanzte Ecken, um die zuletzt benutzte Seite wiederzufinden

	L + C		
A5 - 14,8 x 21	119231C	3	30
A4 - 21 x 29,7	119230C	3	15



A5



A4

Papier vélin velouté 90 g - Couverture polypro | 90 g brushed vellum paper - Polypro cover | 90 g Velinpapier- Deckel aus Polypro

Photos non contractuelles - Photos are not contractually binding - Bild verträglich nicht bindend

Gestion du temps Agenda S'organiser

**Time management - Diary - Get organized
Zeitmanagement - Tagebuch - Organisieren Sie sich**



Webplanner 2024

Rhodia, dont le bloc-notes est plébiscité dans plus de 90 pays à travers le monde, vous présente sa collection d'agendas. Pensés pour tous les styles de vie d'aujourd'hui, simples et épurés, ils sont déclinés en deux formats et deux grilles pour bien s'organiser : que vous ayez besoin d'efficacité, de liberté ou d'anticipation, il y a toujours un Webplanner Rhodia pour personnaliser votre gestion du temps !

Rhodia, whose iconic stapled notepad is popular in over 90 countries around the world, presents its collection of diaries. Designed for today's lifestyles, simple and uncluttered, they come in two formats and two grids to help you get organised: whether you need efficiency, freedom or anticipation, there is always a Rhodia Webplanner to personalise your time management!

Rhodia, bekannt für seine Notizblöcke in über 90 Ländern weltweit, stellt Ihnen seine Terminkalender-Kollektion vor. Ob Sie nun Effizienz, Freiheit oder Vorausschau benötigen, es gibt immer einen Rhodia Webplaner, um Ihr Zeitmanagement zu personalisieren!

2 formats / 2 sizes / 2 Formate



8 coloris / 8 colors / 8 Farben



Papier vélin velouté Clairefontaine 90 g ivoire - Couverture simili cuir 90 g Clairefontaine brushed ivory paper - Leatherette cover
elfenbeinfarbenes samtweiches Velinpapier 90 g - Deckel aus italienischem Kunstleder

2 grilles / 2 grids / 2 Raster

grille horizontale / horizontal grid / horizontales Raster

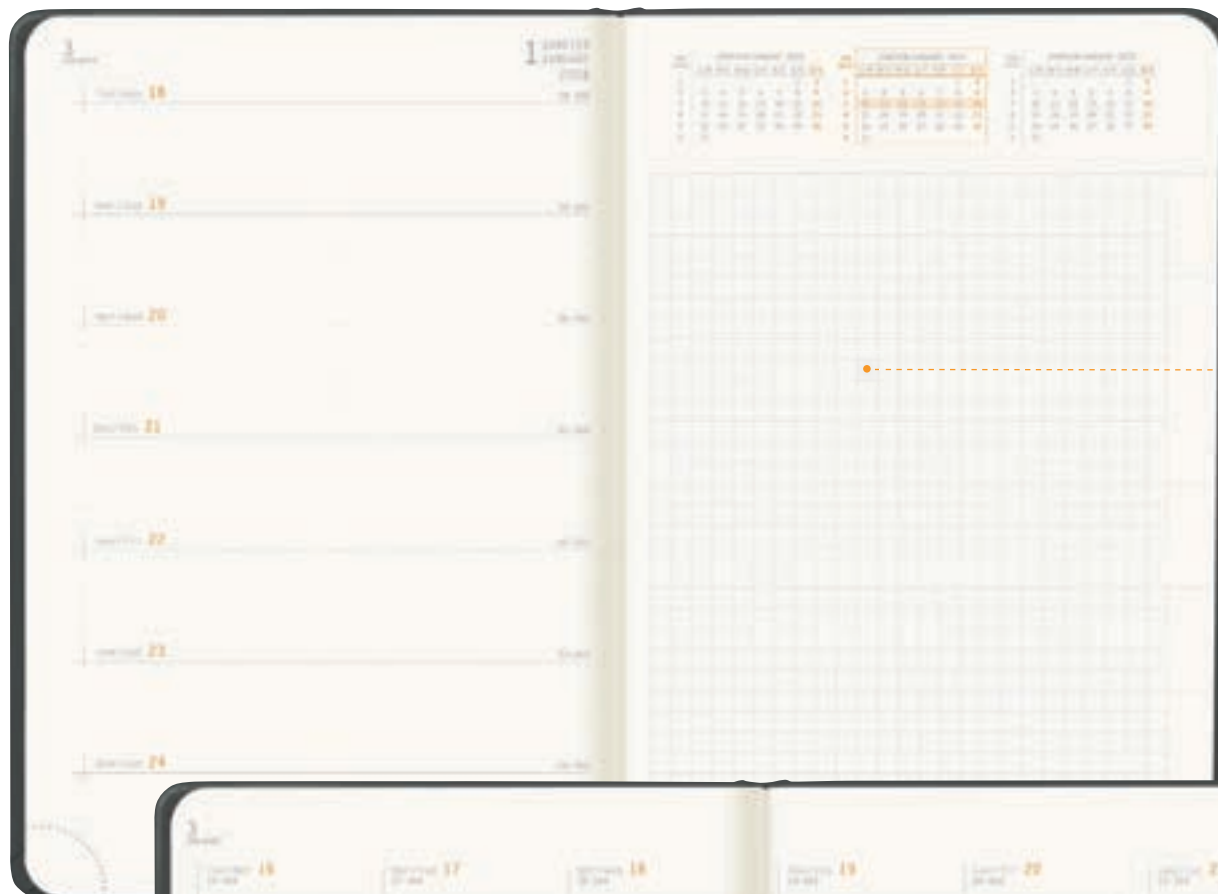

page libre de prise
de notes
free note taking
page
freie Seite zum
Notizenmachen

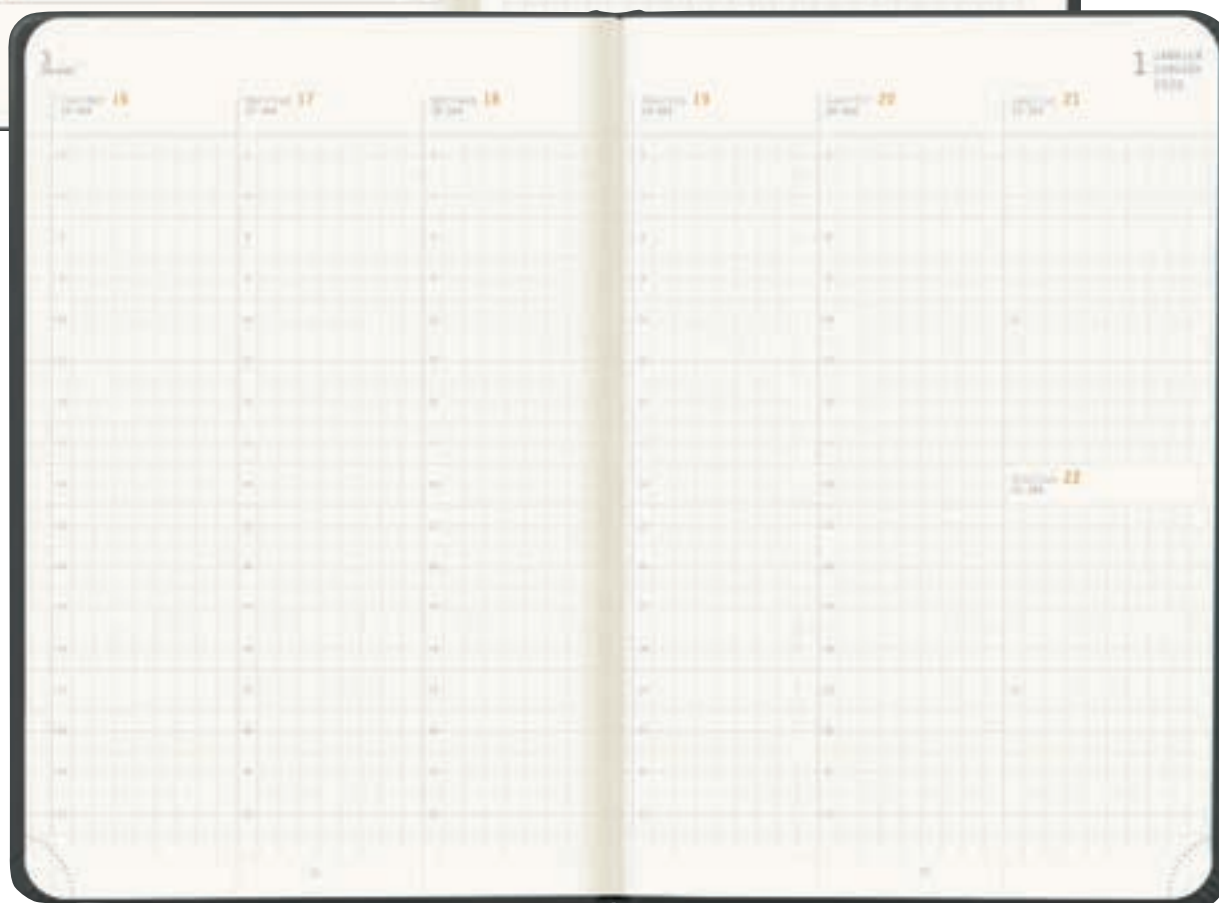

grille verticale / vertical grid / senkrechtes Raster

Papier vélin velouté Clairefontaine 90 g ivoire - Couverture simili cuir 90 g Clairefontaine brushed ivory paper - Leatherette cover
elfenbeinfarbenes samtweiches Velinpapier 90 g - Deckel aus italienischem Kunstleder

Webplanner 2024 grille horizontale

Horizontal grid webplanner

Horizontaler Raster-Webplaner

- Agendas à couverture rembourrée rigide en simili cuir italien, logo et année 2024 embossés (face et dos), fermeture élastique assortie à la couleur de la couverture, 160 pages, papier vélin velouté Clairefontaine 90 g ivoire, ruban marque-page assorti à la couleur de la couverture, coins microperforés, pochette à soufflets et pages de garde orange
- Italian leatherette hard cover diaries, embossed logo and year 2024 (front and back), elastic closure matching the color of the cover, 160 pages, 90 gsm Clairefontaine brushed ivory paper, bookmark ribbon matching the color of the cover microperforated corners, gusseted pocket and orange front and back pages
- Terminkalender mit festem Einband aus italienischem Kunstleder, geprägtes Logo und Jahr 2024 (Vorder- und Rückseite), Gummizugverschluss in der Farbe des Einbands, 160 Seiten, samtweiches Velinpapier Clairefontaine 90 g elfenbeinfarben, Lesezeichenband in der Farbe des Einbands, mikroperforierte Ecken, Falttasche und orangefarbene Deckblätter



A6



A5

8
couleurs
colors
Farben

	A6 10 x 15	A5 14,8 x 21	MINI	
or - gold - gold	194216C NEW	194255C NEW	1	1
titane - titanium - Titan	194217C NEW	194256C NEW	1	1
orange - orange	194218C NEW	194257C NEW	1	1
noir - black - schwarz	194219C NEW	194258C NEW	1	1
paon - peacock - Pfau	194220C NEW	194259C NEW	1	1
bleu nuit - midnight - mitternachtsblau	194221C NEW	194260C NEW	1	1
coquelicot - poppy - Mohn	194222C NEW	194261C NEW	1	1
lie de vin - burgundy - Burgund	194223C NEW	194262C NEW	1	1



Filmé individuellement - Individually shrink-wrapped - Einzeln in Folie eingeschweißt

grille horizontale / horizontal grid / horizontales Raster



Papier vélin velouté Clairefontaine 90 g ivoire - Couverture simili cuir 90 g Clairefontaine brushed ivory paper - Leatherette cover
elfenbeinfarbenes samtweiches Velinpapier 90 g - Deckel aus italienischem Kunstleder





Papier vélin velouté Clairefontaine 90 g ivoire - Couverture simili cuir 90 g Clairefontaine brushed ivory paper - Leatherette cover
 elfenbeinfarbenes samtweiches Velinpapier 90 g - Deckel aus italienischem Kunstleder

Webplanner 2024 grille verticale

Vertical grid Webplanner

Vertikaler Raster-Webplaner

- Agendas à couverture rembourrée rigide en simili cuir italien, logo et année 2024 embossés (face et dos), fermeture élastique assortie à la couleur de la couverture, 160 pages, papier vélin velouté Clairefontaine 90 g ivoire, ruban marque-page assorti à la couleur de la couverture, coins microperforés, pochette à soufflets et pages de garde orange

- Italian leatherette hard cover diaries, embossed logo and year 2024 (front and back), elastic closure matching the color of the cover, 160 pages, 90 gsm Clairefontaine brushed ivory paper, bookmark ribbon matching the color of the cover microperforated corners, gusseted pocket and orange front and back pages

- Terminkalender mit festem Einband aus italienischem Kunstleder, geprägtes Logo und Jahr 2024 (Vorder- und Rückseite), Gummizugverschluss in der Farbe des Einbands, 160 Seiten, samtweiches Velinpapier Clairefontaine 90 g elfenbeinfarben, Lesezeichenband in der Farbe des Einbands, mikroperforierte Ecken, Falttasche und orangefarbene Deckblätter



A6



A5

8
couleurs
colors
Farben

	A6 10 x 15	A5 14,8 x 21	MINI	
or - gold - gold	194134C NEW	194247C NEW	1	1
titane - titanium - Titan	194135C NEW	194248C NEW	1	1
orange - orange	194137C NEW	194249C NEW	1	1
noir - black - schwarz	194138C NEW	194250C NEW	1	1
paon - peacock - Pfau	194139C NEW	194251C NEW	1	1
bleu nuit - midnight - Mitternachtsblau	194140C NEW	194252C NEW	1	1
coquelicot - poppy - Mohn	194141C NEW	194253C NEW	1	1
lie de vin - burgundy - Burgund	194142C NEW	194254C NEW	1	1



Filmé individuellement - Individually shrink-wrapped - Einzeln in Folie eingeschweißt

grille verticale / vertical grid / senkrechtes Raster



Papier vélin velouté Clairefontaine 90 g ivoire - Couverture simili cuir 90 g Clairefontaine brushed ivory paper - Leatherette cover
elfenbeinfarbenes samtweiches Velinpapier 90 g - Deckel aus italienischem Kunstleder





RHODIATIME

Photos non contractuelles - Photos are not contractually binding - Bild vertraglich nicht bindend

Papier vélin velouté Clairefontaine 90 g ivoire - Couverture simili cuir 90 g Clairefontaine brushed ivory paper - Leatherette cover
 elfenbeinfarbenes samtweiches Velinpapier 90 g - Deckel aus italienischem Kunstleder

Sous-main semainier non daté A4+ & A3+

Undated weekly desk pad

Undatierte Wochenplaner-Schreibtischunterlage A4+ & A3+



- 60 feuillets détachables microperforés, dos entoilé, sole cartonnée, dessous antidérapant
- 60 detachable microperforated sheets, clothbound, cardboard backed, nonskid backing
- 60 mikroperforierte, abtrennbare Blätter, Rückseite bespannt, kartonierte Sohle, rutschfeste Unterseite

A4+ - 29,7 x 22,2	194040C		1
A3+ - 42 x 30,9	194041C		1

Filmé individuellement - Individually shrink-wrapped
Einzel in Folie eingeschweißt

3 formats disponibles :

3 sizes available :

3 Formate erhältlich :

A4+ L.29,7 x l.22,2

A3+ L.42 x l.30,9

A2 L.59,4 x l.42 cm (voir / see p. 88 / siehe S. 88)



Sous-main semainier : la praticité du sous-main, la fonctionnalité du semainier.

Deux-en-un, le sous-main semainier est à la fois support du clavier/souris et outil d'organisation et de gestion du temps. Parfait pour être efficace et productif, rester concentré, se projeter et avoir une visibilité de chaque instant sur la semaine en cours, côté pro (rendez-vous, réunions, échéances, urgences, objectifs, déjeuners d'affaire...) ou côté perso (listes de tâches, rendez-vous, projets, activités, anniversaires...). Outre les sections utiles, un espace de prise de notes libres, pour laisser libre cours à son imagination, inscrire rapidement un numéro... ou, pourquoi pas, griffonner pendant un appel téléphonique !

Weekly desk pad : practical as a desk pad, functional as a weekly planner.

A two-in-one product, the desk pad is both a keyboard/mouse support and a time management and organization tool. Perfect to be efficient and productive, to stay focused, to project yourself and to have an immediate visibility on the current week, whether on the professional side (appointments, meetings, deadlines, goals, business lunches...) or on the personal side (task lists, appointments, projects, activities, birthdays...). In addition to the useful sections, there is also a free note-taking area, where you can let your imagination run wild, quickly write down a number... or, why not, scribble during a phone call!

Schreibtischunterlage mit Wochenplaner: Praktisch wie eine Schreibtischunterlage, funktional wie ein Wochenplaner.

Die Schreibtischunterlage ist eine Kombination aus Tastatur-/Maushalter und Organisationshilfe für das Zeitmanagement. Perfekt, um effizient und produktiv zu sein, konzentriert zu bleiben, sich einen Überblick über die laufende Woche im Beruf zu verschaffen (Termine, Besprechungen, Fristen, Dringlichkeiten, Ziele, Geschäftsessen...) oder im Privatleben (Aufgabenlisten, Termine, Vorhaben, Aktivitäten, Geburtstage...). Neben den nützlichen Abschnitten gibt es auch einen Bereich für freie Notizen, in dem Sie Ihrer Fantasie freien Lauf lassen, schnell eine Nummer notieren... oder, warum nicht, während eines Telefonats kritzeln können!



Papier vélin surfín 80 g | 80 g superfine vellum paper | 80 g Velinpapier

rhodiatime

Sous-main semainier non daté A2

Undated weekly desk pad

Undatierte A2-Wochenplaner-Schreibtischunterlage



- 30 feuillets encollées détachables, sole cartonnée, dessous antidérapant
- 30 glued detachable sheets, cardboard backed, nonskid backing
- 30 geleimte, abtrennbare Blätter, kartonierte Sohle, rutschfeste Unterseite

A2 - 59,4 x 42	194042C	1
----------------	---------	---

Filmé individuellement - Individually shrink-wrapped
Einzel in Folie eingeschweißt

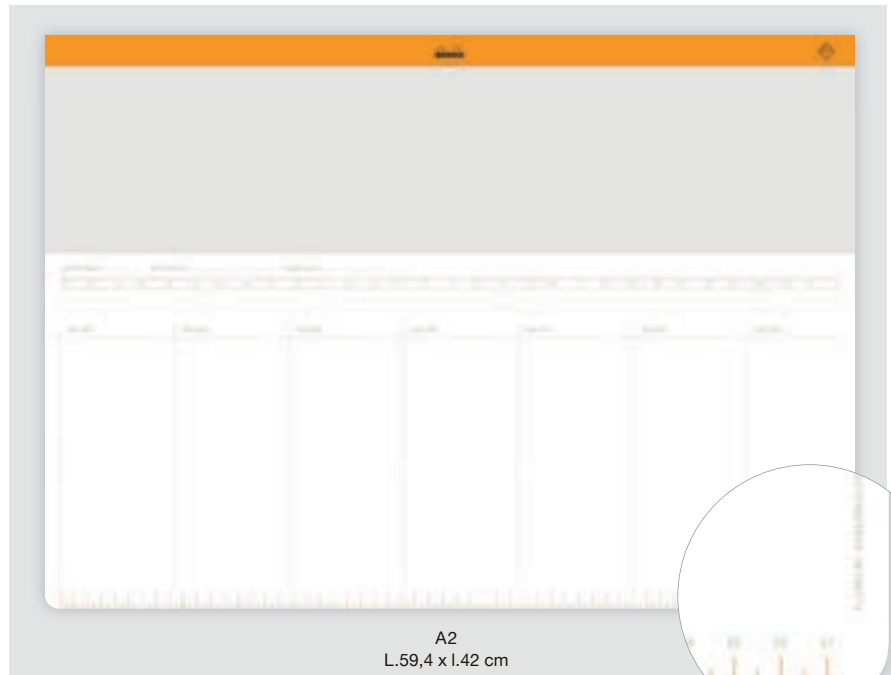

A2
L.59,4 x l.42 cm

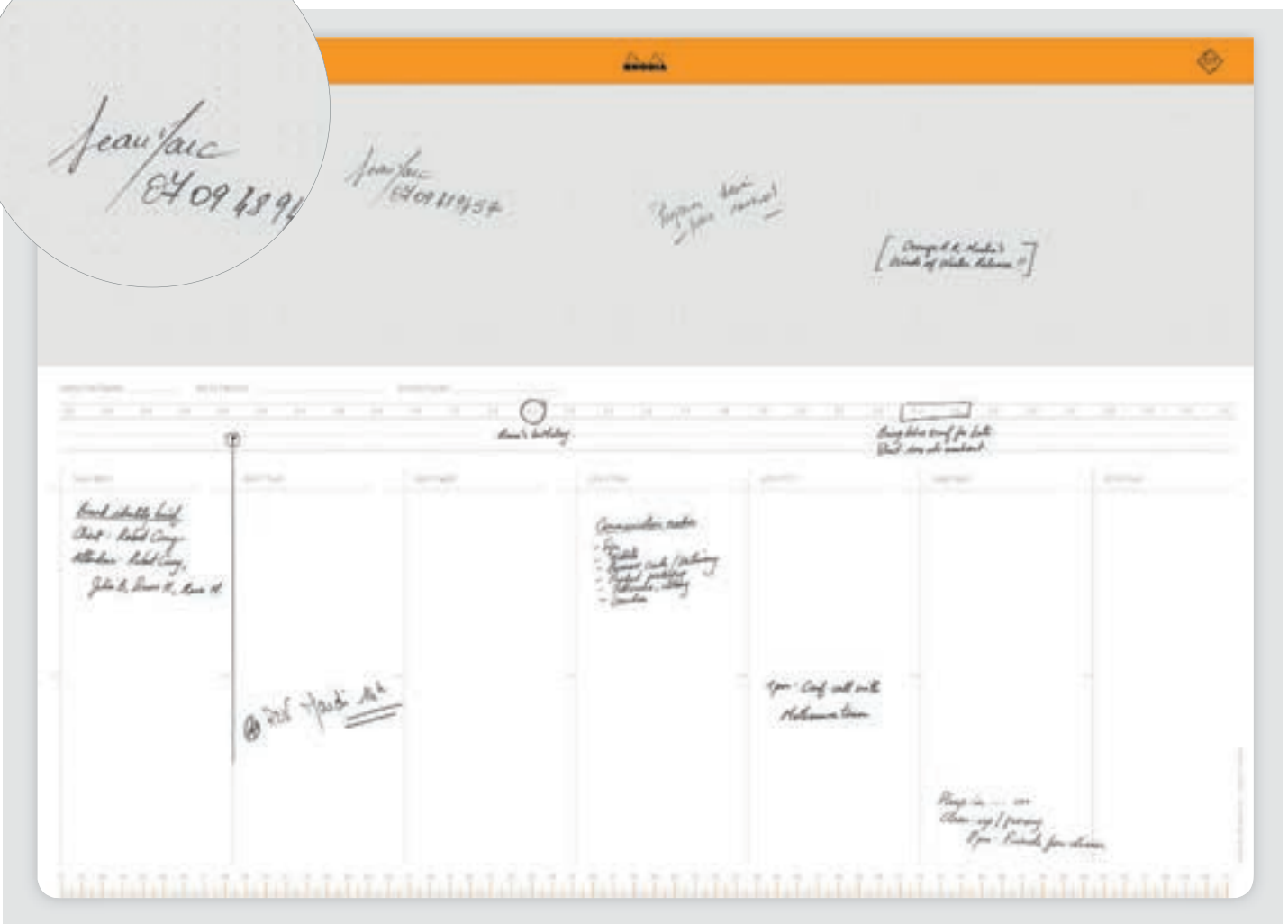

Papier vélin surfin 80 g | 80 g superfine vellum paper | 80 g Velinpapier





Blocs Memo N°11 et N°13

N°11 and N°13 Memo pads

Memoblock Nr. 11 und Nr. 13



- 240 feuillets détachables encollés en tête, sole cartonnée, dessous antidérapant
- 240 detachable glued on top sheets, cardboard backed, nonskid backing
- 240 am Kopfende geleimte, abtrennbare Blätter, kartonierte Sohle, rutschfeste Unterseite

	5/5	L	dot	
N°11 7,5 x 10,5	194043C	194044C	194045C	1
N°13 10,5 x 14,8	194046C	194047C	194048C	1

Filmé individuellement - Individually shrink-wrapped - Einzeln in Folie eingeschweißt

3 réglures disponibles
3 rulings available
3 Lineaturen erhältlich

N°11 - 7,5 x 10,5 cm



5/5

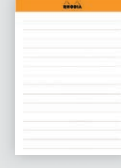

L



DOT

N°13 - 10,5 x 14,8 cm



5/5



L



DOT

Existe aussi en coffret
Also available in a box set
Existiert auch als Set
(voir / see p. 92 / siehe S.92)

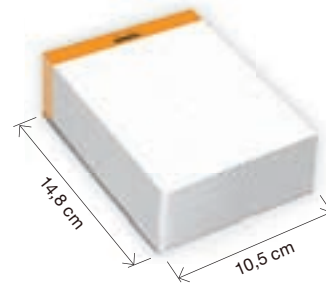
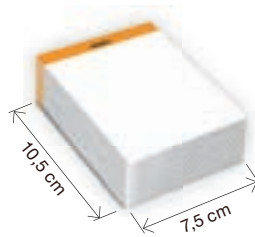

Papier vélin surfin 80 g | 80 g superfine vellum paper | 80 g Velinpapier

Un bloc Memo qui a belle allure, dans son petit coffret aux faux airs de bloc agrafé, toujours à portée de main sur votre bureau. Pour tout noter spontanément ou mémoriser, pour griffonner. Pour transmettre facilement une note volante, une information sur le pouce, grâce à ses feuillets qui se détachent d'un geste. Disponible en deux formats, le N°11 pratique et très compact, et le N°13 offrant davantage d'espace d'expression.

A Memo pad that looks great, in its little box with a Rhodia look, always at hand on your desk. To write down everything spontaneously or to memorize, to scribble. To easily transmit a note, a piece of information on the go, thanks to sheets that detach with a gesture. Available in two sizes, the practical and very compact N°11, and the N°13 offering more space for expression.

Ein Memoblock, der in seinem kleinen Etui aussieht wie ein Heftblock, und auf Ihrem Schreibtisch immer griffbereit ist. Zum spontanen Notieren oder Merken und zum Kritzeln. Dank der Blätter, die sich mit einem Handgriff abtrennen lassen, können Sie eine lose Notiz oder eine Information ganz einfach weitergeben. Erhältlich in zwei Formaten, der praktischen und sehr kompakten Nr. 11 und der Nr. 13 mit mehr Platz zum Schreiben.



Photos non contractuelles - Photos are not contractually binding - Bild vertraglich nicht bindend

Coffrets blocs Memo N°11 et N°13

N°11 and N°13 Memo pad boxes

Memoblock-Etuis Nr. 11 und Nr. 13

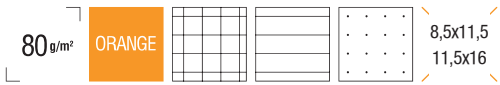

- Contient un bloc Memo N°11 ou N°13 de 240 feuillets détachables encollés en tête
- Contains a N°11 or N°13 Memo pad of 240 detachable glued on top sheets
- Enthält einen Memoblock Nr.11 oder Nr.13 mit 240 am Kopfende geleimten, abtrennbaren Blättern

	5/5	L	dot	
N°11 - 8,5 x 11,5	194049C	194050C	194051C	1
N°13 - 11,5 x 16	194052C	194053C	194054C	1

Filmé individuellement - Individually shrink-wrapped - Einzeln in Folie eingeschweißt

2 formats disponibles
2 sizes available
2 Größen erhältlich

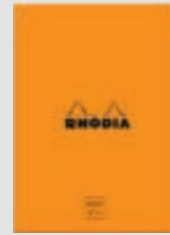

N°11
8,5 x 11,5 cm

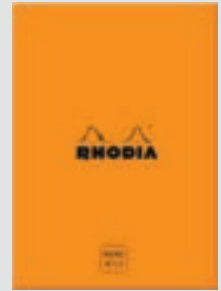

N°13
11,5 x 16 cm

Disponible en 3 réglures
Available in 3 rulings
Erhältlich in 3 Lineaturen

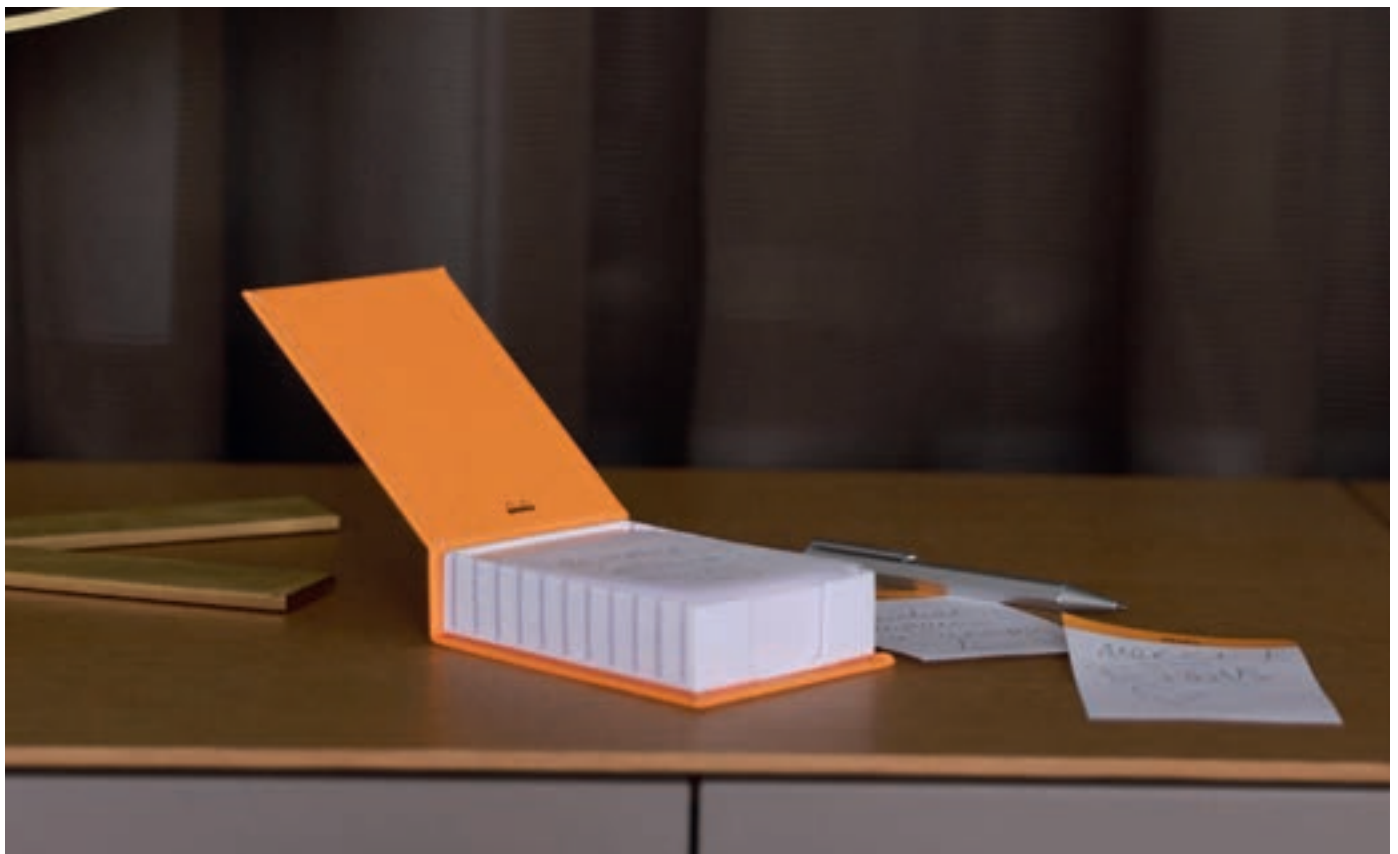
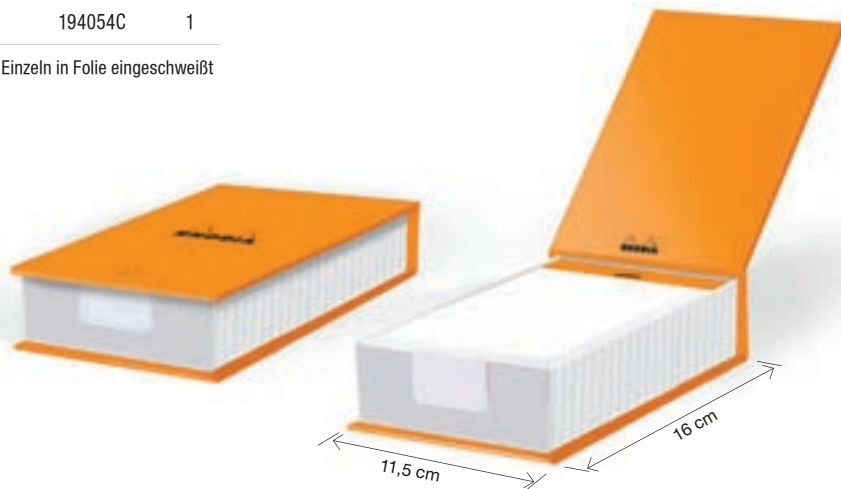

Papier vélin surfin 80 g | 80 g superfine vellum paper | 80 g Velinpapier



Papier vélin surfín 80 g | 80 g superfine vellum paper | 80 g Velinpapier

Plaisir d'écrire Authenticité & raffinement Intemporel

**Writing experience - Authenticity and refinement - Timeless
Erfahrung beim Schreiben - Authentizität und Raffinesse - Zeitlos**



Authentiques et intemporels, les instruments d'écriture Rhodia sont à la fois sobres et raffinés. Directement inspirés par l'identité forte de l'icône bloc Rhodia.

Authentic and timeless writing instruments, both simple and refined. Inspired by the character and design of the iconic stapled Rhodia notepad.

Die authentischen und zeitlosen Schreibgeräte von Rhodia sind gleichzeitig schlicht und raffiniert. Direkt inspiriert von der starken Identität des ikonischen Rhodia-Blocks.



Portemine 0,5 mm
0,5 mm mechanical pencil
Druckbleistift 0,5 mm

Crayon à papier HB
Rhodia pencil
Rhodia Bleistift



MULTI PEN 3-en-1

3-in-1 MULTI PEN

3-in-1 MULTI PEN

OR
GOLD

- Corps hexagonal en aluminium brossé, 2 pointes billes haute précision noire & rouge 0,5 mm et 1 pointe graphite 0,5 mm, vendu en boîte cartonnée à fenêtre
- Brushed aluminum hexagonal body, 0,5 mm high-precision black & red ballpoint tips and a 0,5 mm graphite lead tip, comes in a cardboard box with window
- Sechskantiger Schaft aus gebürstetem Aluminium, 2 hochpräzise Kugelspitzen schwarz & rot 0,5 mm und 1 Graphitspitze 0,5 mm, angeboten in einer Kartonbox mit Fenster

Longueur - length - Länge 13,5 cm Ø 1 cm		MINI	📦	
or - gold - gold	9345C NEW	2	1	
recharge Multi Pen encre noire - Multi Pen refill black ink - Nachfüllminen schwarze Tinte für MULTI PEN	9283C	5	1	
recharge Multi Pen encre rouge - Multi Pen refill red ink - Nachfüllminen rote Tinte für MULTI PEN	9284C	5	1	

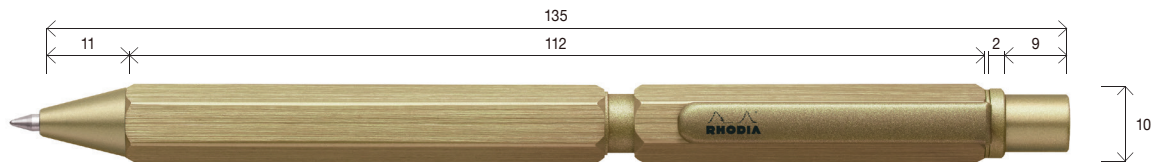

Taille réelle - Real size - Originalgröße

WRITING



MULTI PEN 3-en-1





3-in-1 MULTI PEN

3-in-1 MULTI PEN

ORANGE

NOIR
BLACK
SCHWARZ

- Corps hexagonal en aluminium brossé, 2 pointes billes haute précision noire & rouge 0,5 mm et 1 pointe graphite 0,5 mm, vendu en boîte cartonnée à fenêtre
- Brushed aluminum hexagonal body, 0,5 mm high-precision black & red ballpoint tips and a 0,5 mm graphite lead tip, comes in a cardboard box with window
- Sechskantiger Schaft aus gebürstetem Aluminium, 2 hochpräzise Kugelspitzen schwarz & rot 0,5 mm und 1 Graphitspitze 0,5 mm, angeboten in einer Kartonbox mit Fenster

Longueur - length - Länge 13,5 cm Ø 1 cm		MINI	📦
	orange - orange	9340C	2 1
	noir - black - schwarz	9342C	2 1
	sauge - sage - Salbei	9344C NEW	2 1
	recharge Multi Pen encre noire - Multi Pen refill black ink - Nachfüllminen schwarze Tinte für MULTI PEN	9283C	5 1
	recharge Multi Pen encre rouge - Multi Pen refill red ink - Nachfüllminen rote Tinte für MULTI PEN	9284C	5 1

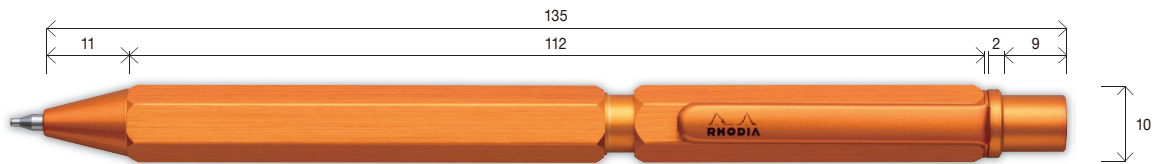

Taille réelle - Real size - Originalgröße

Stylo à bille noir
 Porte mines
 Stylo à bille rouge



rhodia writing

Stylo à bille 0,7 mm

0,7 mm ballpoint pen

0,7 mm Kugelschreiber



OR
GOLD

- Corps hexagonal en aluminium brossé, pointe rétractable à bille haute précision 0,7 mm, vendu en boîte cartonnée à fenêtre
- Brushed aluminum hexagonal body, retractable high-precision 0.7 mm ballpoint tip, comes in a cardboard box with window
- Sechskantiger Schaft aus gebürstetem Aluminium, versenkbare Kugelschreiberspitze mit hoher Präzision 0,7 mm, wird in einer Kartonschachtel mit Fenster verkauft



Sous étui de protection en plastique transparent pegboardable

Inside a protective transparent plastic case

In einer schützenden, transparenten Kunststoffhülle

Longueur - length - Länge 12,8 cm Ø 1 cm			MINI	
	or - gold - gold	9360C NEW	2	1
	recharge encre noire - refill black ink Nachfüllminen schwarze Tinte	9280C	5	1
	recharge encre bleue- refill blue ink Nachfüllminen blaue Tinte	9282C	5	1

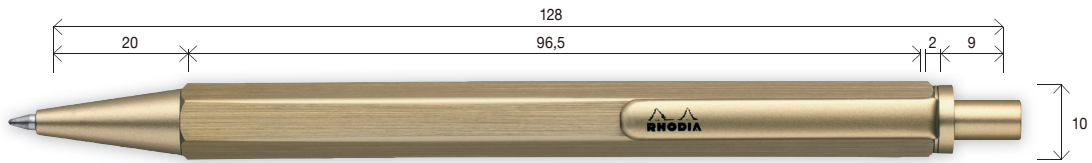

Taille réelle - Real size - Originalgröße

WRITING



Portemine 0,5 mm

0,5 mm mechanical pencil

0,5 mm Druckbleistift



OR
GOLD

- Corps hexagonal en aluminium brossé, pour mines graphite standards 0,5 mm, canon en acier rétractable, gomme sous le poussoir, vendu en boîte cartonnée à fenêtre
- Brushed aluminum hexagonal body, for standard 0.5 mm graphite leads, retractable steel barrel, eraser under the push button, comes in a cardboard box with window
- Sechskantiger Schaft aus gebürstetem Aluminium, für 0,5 mm Standard-Graphitminen, versenkbare Stahlhülse, Radiergummi unter dem Druckstück, wird in einer Kartonschachtel mit Fenster verkauft



Sous étui de protection en plastique transparent pegboardable

Inside a protective transparent plastic case

In einer schützenden, transparenten Kunststoffhülle

Longueur - length - Länge 12,8 cm Ø 1 cm		MINI	
or - gold - gold	9370C NEW	2	1



Taille réelle - Real size - Originalgröße



rhodia writing

Stylo à bille 0,7 mm

0,7 mm ballpoint pen

0,7 mm Kugelschreiber

SAUGE
SAGE
SALBEI

- Corps hexagonal en aluminium brossé, pointe rétractable à bille haute précision 0,7 mm, vendu en boîte cartonnée à fenêtre
- Brushed aluminum hexagonal body, retractable high-precision 0.7 mm ballpoint tip, comes in a cardboard box with window
- Sechskantiger Schaft aus gebürstetem Aluminium, versenkbare Kugelschreiberspitze mit hoher Präzision 0,7 mm, wird in einer Kartonschachtel mit Fenster verkauft

Longueur - length - Länge 12,8 cm Ø 1 cm		MINI	
	sauge - sage - Salbei	9387C	2 1
	recharge encre noire - refill black ink Nachfüllmine schwarze Tinte	9280C	5 1
	recharge encre bleue - refill blue ink Nachfüllmine blaue Tinte	9282C	5 1



Sous étui de protection en plastique transparent pegboardable

Inside a protective transparent plastic case

In einer schützenden, transparenten Kunststoffhülle

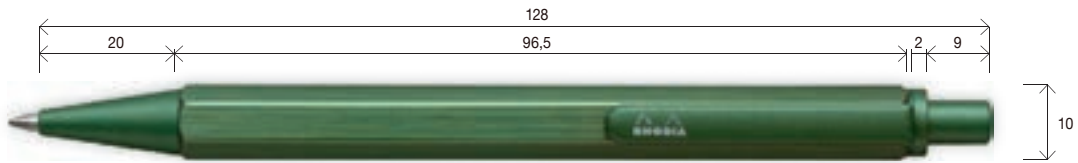

Taille réelle - Real size - Originalgröße

WRITING



Portemine 0,5 mm

0,5 mm mechanical pencil

0,5 mm Druckbleistift

SAUGE
SAGE
SALBEI



- Corps hexagonal en aluminium brossé, pour mines graphite standards 0,5 mm, canon en acier rétractable, gomme sous le poussoir, vendu en boîte cartonnée à fenêtre
- Brushed aluminum hexagonal body, for standard 0.5 mm graphite leads, retractable steel barrel, eraser under the push button, comes in a cardboard box with window
- Sechskantiger Schaft aus gebürstetem Aluminium, für 0,5 mm Standard-Graphitminen, versenkbare Stahlhülse, Radiergummi unter dem Druckstück, wird in einer Kartonschachtel mit Fenster verkauft



Sous étui de protection en plastique transparent pegboardable

Inside a protective transparent plastic case

In einer schützenden, transparenten Kunststoffhülle

Longueur - length - Länge 12,8 cm Ø 1 cm		MINI	
	sauge - sage - Salbei	9397C	2 1

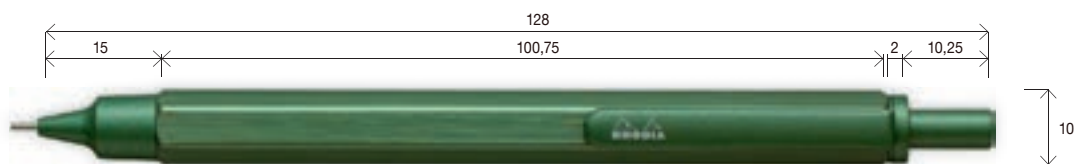

Taille réelle - Real size - Originalgröße



rhodia writing

Stylo à bille 0,7 mm

0,7 mm ballpoint pen

0,7 mm Kugelschreiber

TURQUOISE
TÜRKIS

- Corps hexagonal en aluminium brossé, pointe rétractable à bille haute précision 0,7 mm, vendu en boîte cartonnée à fenêtre
- Brushed aluminum hexagonal body, retractable high-precision 0.7 mm ballpoint tip, comes in a cardboard box with window
- Sechskantiger Schaft aus gebürstetem Aluminium, versenkbare Kugelschreiberspitze mit hoher Präzision 0,7 mm, wird in einer Kartonschachtel mit Fenster verkauft

Longueur - length - Länge 12,8 cm Ø 1 cm			MINI	
	turquoise - türkis	9386C	2	1
	recharge encre noire - refill black ink Nachfüllmine schwarze Tinte	9280C	5	1
	recharge encre bleue- refill blue ink Nachfüllmine blaue Tinte	9282C	5	1



Sous étui de protection en plastique transparent pegboardable

Inside a protective transparent plastic case

In einer schützenden, transparenten Kunststoffhülle

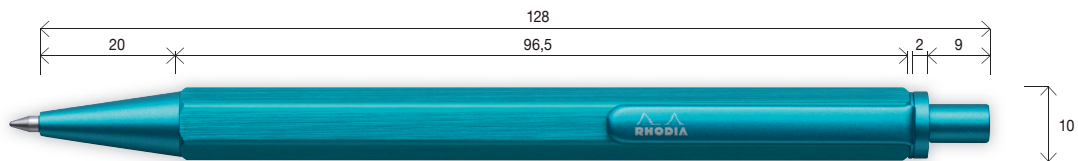

Taille réelle - Real size - Originalgröße

WRITING



Portemine 0,5 mm

0,5 mm mechanical pencil

0,5 mm Druckbleistift

TURQUOISE
TÜRKIS

- Corps hexagonal en aluminium brossé, pour mines graphite standards 0,5 mm, canon en acier rétractable, gomme sous le poussoir, vendu en boîte cartonnée à fenêtre
- Brushed aluminum hexagonal body, for standard 0.5 mm graphite leads, retractable steel barrel, eraser under the push button, comes in a cardboard box with window
- Sechskantiger Schaft aus gebürstetem Aluminium, für 0,5 mm Standard-Graphitminen, versenkbare Stahlhülse, Radiergummi unter dem Druckstück, wird in einer Kartonschachtel mit Fenster verkauft



Sous étui de protection en plastique transparent pegboardable

Inside a protective transparent plastic case

In einer schützenden, transparenten Kunststoffhülle

Longueur - length - Länge 12,8 cm Ø 1 cm		MINI	📦	
turquoise - türkis	9396C	2	1	

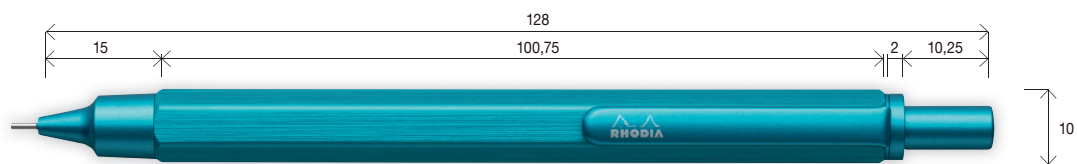

Taille réelle - Real size - Originalgröße



rhodia writing

Stylo à bille 0,7 mm

0,7 mm ballpoint pen

0,7 mm Kugelschreiber

NAVY
MARINE

- Corps hexagonal en aluminium brossé, pointe rétractable à bille haute précision 0,7 mm, vendu en boîte cartonnée à fenêtre
- Brushed aluminum hexagonal body, retractable high-precision 0.7 mm ballpoint tip, comes in a cardboard box with window
- Sechskantiger Schaft aus gebürstetem Aluminium, versenkbare Kugelschreiberspitze mit hoher Präzision 0,7 mm, wird in einer Kartonschachtel mit Fenster verkauft

	Longueur - length - Länge 12,8 cm Ø 1 cm		MINI	
	navy - Navy	9383C	2	1
	recharge encre noire - refill black ink Nachfüllmine schwarze Tinte	9280C	5	1
	recharge encre bleue- refill blue ink Nachfüllmine blaue Tinte	9282C	5	1



Sous étui de protection en plastique transparent pegboardable

Inside a protective transparent plastic case

In einer schützenden, transparenten Kunststoffhülle

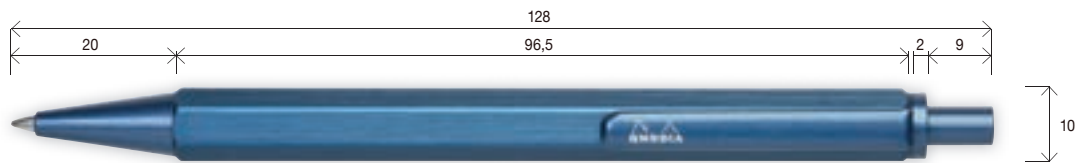

Taille réelle - Real size - Originalgröße

WRITING



Portemine 0,5 mm

0,5 mm mechanical pencil

0,5 mm Druckbleistift

NAVY
MARINE

- Corps hexagonal en aluminium brossé, pour mines graphite standards 0,5 mm, canon en acier rétractable, gomme sous le poussoir, vendu en boîte cartonnée à fenêtre
- Brushed aluminum hexagonal body, for standard 0.5 mm graphite leads, retractable steel barrel, eraser under the push button, comes in a cardboard box with window
- Sechskantiger Schaft aus gebürstetem Aluminium, für 0,5 mm Standard-Graphitminen, versenkbare Stahlkanone, Radiergummi unter dem Drücker, wird in einer Pappschachtel mit Fenster verkauft



Sous étui de protection en plastique transparent pegboardable

Inside a protective transparent plastic case

In einer schützenden, transparenten Kunststoffhülle

Longueur - length - Länge 12,8 cm Ø 1 cm		MINI	
navy - Navy	9393C	2	1

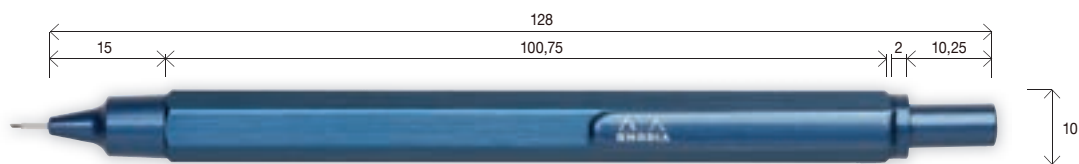

Taille réelle - Real size - Originalgröße



rhodia writing





Stylo à bille 0,7 mm

0,7 mm ballpoint pen

0,7 mm Kugelschreiber

ROUGE
RED
ROT

- Corps hexagonal en aluminium brossé, pointe rétractable à bille haute précision 0,7 mm, vendu en boîte cartonnée à fenêtre
- Brushed aluminum hexagonal body, retractable high-precision 0.7 mm ballpoint tip, comes in a cardboard box with window
- Sechskantiger Schaft aus gebürstetem Aluminium, versenkbare Kugelschreiberspitze mit hoher Präzision 0,7 mm, wird in einer Kartonschachtel mit Fenster verkauft

	Longueur - length - Länge 12,8 cm Ø 1 cm		MINI	
	rouge - red - rot	9384C	2	1
	recharge encre noire - refill black ink Nachfüllmine schwarze Tinte	9280C	5	1
	recharge encre bleue- refill blue ink Nachfüllmine blaue Tinte	9282C	5	1



Sous étui de protection en plastique transparent pegboardable

Inside a protective transparent plastic case

In einer schützenden, transparenten Kunststoffhülle

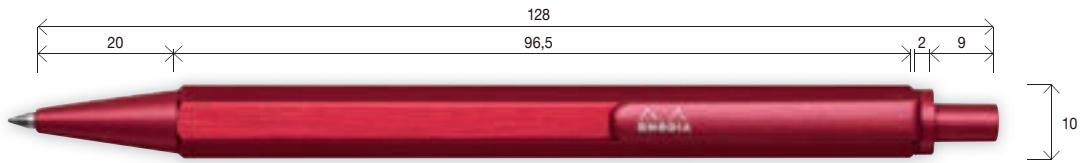

Taille réelle - Real size - Originalgröße

WRITING



Portemine 0,5 mm

0,5 mm mechanical pencil

0,5 mm Druckbleistift

ROUGE
RED
ROT

- Corps hexagonal en aluminium brossé, pour mines graphite standards 0,5 mm, canon en acier rétractable, gomme sous le poussoir, vendu en boîte cartonnée à fenêtre
- Brushed aluminum hexagonal body, for standard 0.5 mm graphite leads, retractable steel barrel, eraser under the push button, comes in a cardboard box with window
- Sechskantiger Schaft aus gebürstetem Aluminium, für 0,5 mm Standard-Graphitminen, versenkbare Stahlhülse, Radiergummi unter dem Druckstück, wird in einer Kartonbox mit Fenster verkauft

Longueur - length - Länge 12,8 cm Ø 1 cm		MINI		
■	rouge - red - rot	9394C	2	1



Sous étui de protection en plastique transparent pegboardable

Inside a protective transparent plastic case

In einer schützenden, transparenten Kunststoffhülle

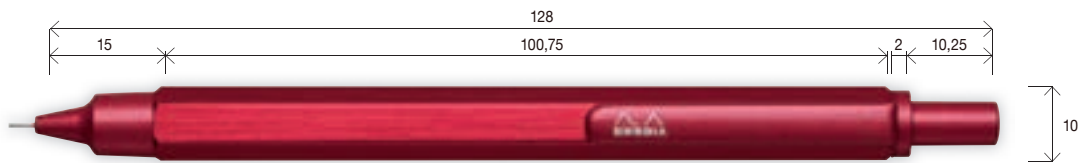

Taille réelle - Real size - Originalgröße



WRITING

Photos non contractuelles - Photos are not contractually binding - Bild vertraglich nicht verbindlich

rhodia writing

Stylo à bille 0,7 mm

0,7 mm ballpoint pen

0,7 mm Kugelschreiber

BOIS de ROSE
ROSEWOOD
ROSENHOLZ

- Corps hexagonal en aluminium brossé, pointe rétractable à bille haute précision 0,7 mm, vendu en boîte cartonnée à fenêtre
- Brushed aluminum hexagonal body, retractable high-precision 0.7 mm ballpoint tip, comes in a cardboard box with window
- Sechskantiger Schaft aus gebürstetem Aluminium, versenkbare Kugelschreiberspitze mit hoher Präzision 0,7 mm, wird in einer Kartonbox mit Fenster verkauft

Longueur - length - Länge 12,8 cm Ø 1 cm		MINI	
	bois de rose - rosewood - Rosenholz	9385C	2 1
	recharge encre noire - refill black ink Nachfüllmine schwarze Tinte	9280C	5 1
	recharge encre bleue - refill blue ink Nachfüllmine blaue Tinte	9282C	5 1



Sous étui de protection en plastique transparent pegboardable

Inside a protective transparent plastic case

In einer schützenden, transparenten Kunststoffhülle

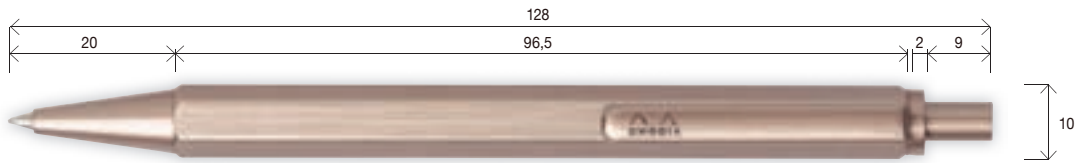

Taille réelle - Real size - Originalgröße



Portemine 0,5 mm

0,5 mm mechanical pencil

0,5 mm Druckbleistift

BOIS de ROSE
ROSEWOOD
ROSENHOLZ

- Corps hexagonal en aluminium brossé, pour mines graphite standards 0,5 mm, canon en acier rétractable, gomme sous le poussoir, vendu en boîte cartonnée à fenêtre
- Brushed aluminum hexagonal body, for standard 0.5 mm graphite leads, retractable steel barrel, eraser under the push button, comes in a cardboard box with window
- Sechskantiger Schaft aus gebürstetem Aluminium, für 0,5 mm Standard-Graphitminen, versenkbare Stahlhülse, Radiergummi unter dem Druckstück, wird in einer Kartonbox mit Fenster verkauft



Sous étui de protection en plastique transparent pegboardable

Inside a protective transparent plastic case

In einer schützenden, transparenten Kunststoffhülle

Longueur - length - Länge 12,8 cm Ø 1 cm		MINI		
bois de rose - rosewood - Rosenholz	9395C	2	1	

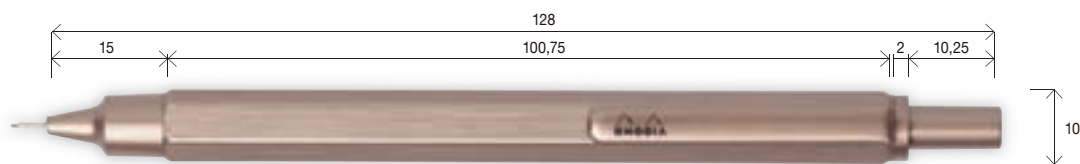

Taille réelle - Real size - Originalgröße



rhodia writing

Stylo à bille 0,7 mm

0,7 mm ballpoint pen

0,7 mm Kugelschreiber



- Corps hexagonal en aluminium brossé, pointe rétractable à bille haute précision 0,7 mm, vendu en boîte cartonnée à fenêtre
- Brushed aluminum hexagonal body, retractable high-precision 0.7 mm ballpoint tip, comes in a cardboard box with window
- Sechskantiger Schaft aus gebürstetem Aluminium, versenkbare Kugelschreiberspitze mit hoher Präzision 0,7 mm, wird in einer Kartonbox mit Fenster verkauft

Longueur - length - Länge 12,8 cm Ø 1 cm		MINI		
	orange - orange	9388C	2	1
	noir - black - schwarz	9389C	2	1
	argent - silver - silber	9381C	2	1
	recharge encre noire - refill black ink Nachfüllmine schwarze Tinte	9280C	5	1
	recharge encre bleue - refill blue ink Nachfüllmine blaue Tinte	9282C	5	1
Présentoir Rhodia scRipt prêt-à-vendre 29 pièces Rhodia scRipt display ready-to-sell 29 pieces Rhodia scRipt-Display verkaufsfertig 29 Stück		9382C*	1	1

*jusqu'à épuisement des stocks - while stocks last - solange der Vorrat reicht

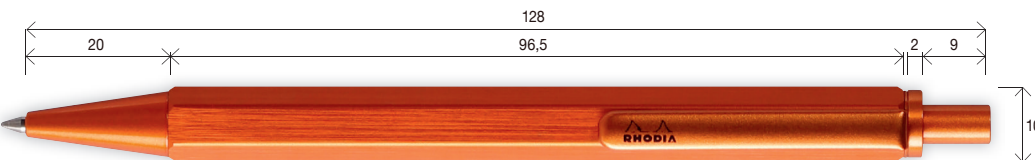

Taille réelle - Real size - Originalgröße



Sous étui de protection en plastique transparent pegboardable

Inside a protective transparent plastic case

In einer schützenden, transparenten Kunststoffhülle



Présentoir « prêt-à-vendre » sélection de 12 portemines + 12 stylos assortis + 5 recharges encre noire transparent pegboardable

Ready-to-sell display of 12 mechanical pencils + 12 ballpoint pens assorted + 5 black ink refills

Verkaufsfertiges Display mit 12 Druckbleistiften + 12 Kugelschreiber assortiert + 5 Ersatzmines schwarze Tinte

WRITING



Portemine 0,5 mm

0,5 mm mechanical pencil

0,5 mm Druckbleistift



- Corps hexagonal en aluminium brossé, pour mines graphite standards 0,5 mm, canon en acier rétractable, gomme sous le poussoir, vendu en boîte cartonnée à fenêtre
- Brushed aluminum hexagonal body, for standard 0.5 mm graphite leads, retractable steel barrel, eraser under the push button, comes in a cardboard box with window
- Sechskantiger Schaft aus gebürstetem Aluminium, für 0,5 mm Standard-Graphitminen, versenkbare Stahlhülse, Radiergummi unter dem Druckstück, wird in einer Kartonbox mit Fenster verkauft

Longueur - length - Länge 12,8 cm Ø 1 cm		MINI	📦	
	orange - orange	9398C	2	1
	noir - black - schwarz	9399C	2	1
	argent - silver - silber	9391C	2	1



Sous étui de protection en plastique transparent pegboardable

Inside a protective transparent plastic case

In einer schützenden, transparenten Kunststoffhülle

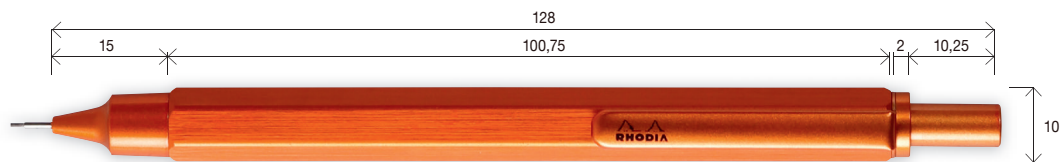

Taille réelle - Real size - Originalgröße



Photos non contractuelles - Photos are not contractual - Bild vertraglich nicht bindend

WRITING

rhodia writing



Crayon à papier HB

Rhodia pencil

Rhodia Bleistift HB

ORANGE

- Corps triangulaire en bois teinté noir, gomme et virole noires, emballé individuellement
- Black triangular wooden body, black eraser and collar, individually wrapped
- Dreieckiger Schaft aus schwarz gebeiztem Holz, schwarzer Radiergummi und schwarze Halterung, einzeln verpackt

	7,5 x 6,5 x 19	
	orange	9020C 25*



* Livrés en boîte carton rigide verticale de 25
Delivered in a 25 pieces vertical hard box display
Geliefert in einem 25-teiligen vertikalen Hartkarton-Display

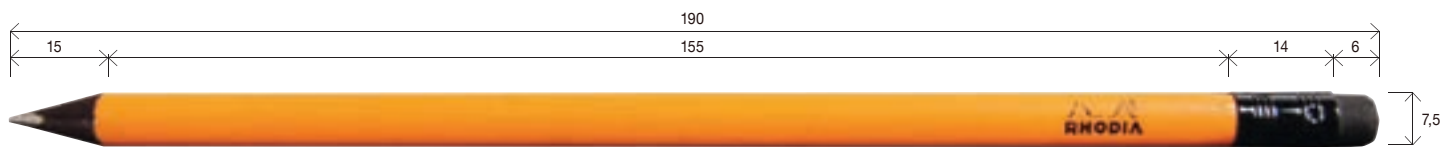

Taille réelle - Real size - Originalgröße



Présentoir Multi Pen

Multi Pen display

Multi Pen Display

	MINI		
Présentoir Rhodia scRipt Multi Pen - à composer Rhodia scRipt Multi Pen display - to be composed Rhodia scRipt Multi Pen Display - zum Zusammenstellen	9302C	1	1

Présentoir livré vide et à composer – nous consulter
Display delivered empty and to be composed - consult us
Display wird leer geliefert und muss individuell
zusammengestellt werden - kontaktieren Sie uns

Capacité du présentoir :
4 Multi Pen Orange + 4 Multi Pen Black
+ 5 recharges rouges + 5 recharges
noires

Display capacity:
4 Multi Pen Orange + 4 Multi Pen Black
+ 5 refills red + 5 refills black

Kapazität des Displays:
4 Multi Pen Orange + 4 Multi Pen
Schwarz + 5 rote Nachfüllminen + 5
schwarze Nachfüllminen



Présentoir Rhodia scRipt

Rhodia scRipt display

Rhodia scRipt-Display

	MINI		
Présentoir Rhodia scRipt 42 pièces - à composer Rhodia scRipt 42 pieces display - to be composed Rhodia scRipt-Display 42 Stück - zum zusammenstellen	9301C	1	1

Présentoir livré vide et à composer – nous consulter
Display delivered empty and to be composed - consult us
Display wird leer geliefert und muss individuell
zusammengestellt werden - kontaktieren Sie uns



Capacité du présentoir : 16 portemines + 16 stylos assortis + 10 recharges
Display capacity: 16 mechanical pencils + 16 ballpoint pens assorted + 10 refills
Kapazität des Displays: 16 Druckbleistifte + 16 Kugelschreiber assortiert + 10 Minen

Présentoir Rhodia scRipt prêt-à-vendre

Rhodia scRipt display ready-to-sell

Rhodia scRipt-Display verkaufsbereit

	MINI		
Présentoir Rhodia scRipt prêt-à-vendre 29 pièces Rhodia scRipt display ready-to-sell 29 pieces Rhodia scRipt-Display verkaufsbereit 29 Stück	9382C*	1	1



Sélection de 12 portemines + 12 stylos assortis + 5 recharges encre noire
12 mechanical pencils + 12 ballpoint pens assorted + 5 black ink refills
12 Druckbleistifte + 12 Kugelschreiber assortiert + 5 schwarze Nachfüllminen

Testeur plexiglas Rhodia scRipt

Rhodia scRipt plexiglass tester

Rhodia scRipt Plexiglas-Tester

	MINI		
Testeur plexiglas Rhodia scRipt avec bloc agrafé Rhodia scRipt plexiglass tester with a stapled pad Rhodia scRipt Plexiglas-Tester mit Heftblock	9303C	1	1



Testeur plexiglas Rhodia scRipt
Rhodia scRipt plexiglass tester
Rhodia scRipt Plexiglas-Tester

rhodia writing



c o l l e c t i o n

s c R i p t

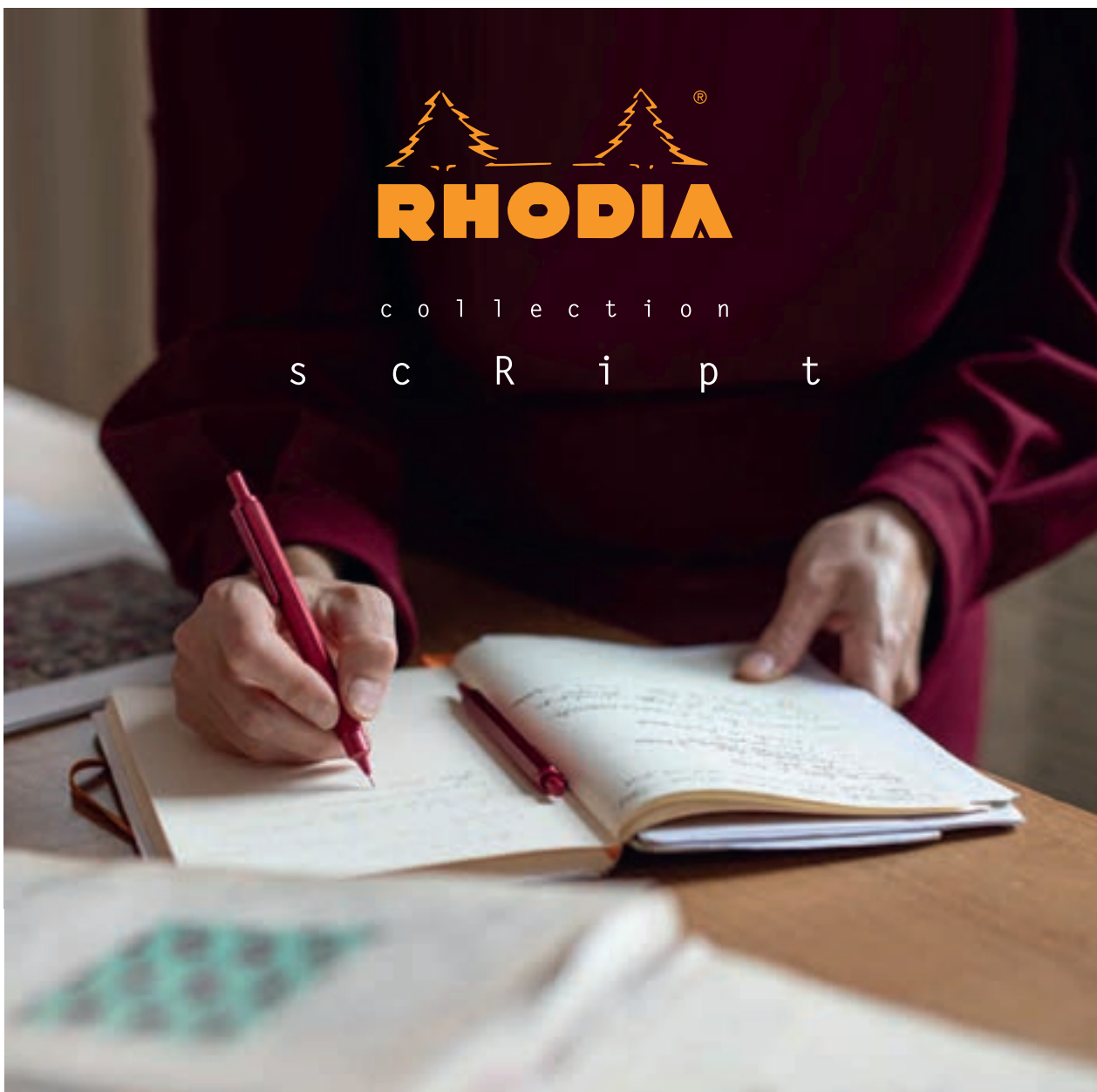

*stylo à bille 0,7 mm ou portemine 0,5 mm
corps en aluminium brossé*

b l o c - r h o d i a . c o m



WRITING

c o l l e c t i o n
s c R i p t

corps en aluminium brossé
portemine 0,5 mm
ou stylo à bille 0,7 mm

bois de rose
turquoise
orange
argent
saugé
rouge
noir
navy
or



RHODIA

blocs, carnets, cahiers, agendas, instruments d'écriture et accessoires

b l o c - r h o d i a . c o m



Quel style! Colorama Home office

What a look! - Colorama - Storage accessories
Was für ein Look! - Colorama - Zubehör für die Aufbewahrung



Photos non contractuelles - Photos are not contractually bound

RHODIARAMA

RHODIARAMA
papeterie - paper products
accessoires - accessories

Format (cm)	Goalbook couverture souple Softcover Goalbook				Goalbook rembourré rigide Hardcover Goalbook				Goalbook Creation rembourré rigide Hardcover Goalbook Creation		Minibook Mini notebook	Carnet souple Softcover notebook						Carnet piqûre textile Sewn spine notebook		Meeting	Perpetual	Carnet rembourré rigide Hardcover notebook				Webnotepad	
	A5		A5		A5		A5		7 x 10,5	A6	A5	B5	A4+	A5		A5+	A5	9 x 14		A5		9 x 14	A5				
	ivoire ivory	blanc white	ivoire ivory	blanc white	ivoire ivory	blanc white	ivoire ivory	noir black	ivoire ivory	ivoire ivory						ivoire ivory	blanc white	ivoire ivory	ivoire ivory				ivoire ivory				
	5 x 5	dot	dot	dot	dot	dot	ivoire ivory	noir black	ligné	ligné	dot	ligné	dot	ligné	dot	ligné + cadre	ligné	dot	date notes action	calendrier perpétuel	uni	ligné	uni	ligné	ligné		
or - gold																											
cuivre - copper																											
bronze- bronze																											
titane - titanium																											
argent - silver																											
blanc - white																											
noir - black																											
chocolat - chocolate																											
taupe																											
beige																											
lie de vin - burgundy																											
nacarat																											
bois de rose - rosewood																											
touche de rose - rose smoke																											
anis - anise																											
sauge - sage																											
céladon - celadon																											
paon - peacock																											
eau - aqua																											
turquoise - turquoise																											
bleu nuit - midnight																											
saphir - sapphire																											
iris																											
violet - purple																											
lilas - lilac																											
fuchsia																											
framboise - raspberry																											
coquelicot - poppy																											
corail - coral																											
tangerine																											
orange																											
jonquille - daffodil																											

Format (cm): A6 10,5 x 14,8 A5 14,8 x 21 A5+ 16 x 21 B5 19 x 25 A4+ 22 x 29,7

Le Goalbook utile & tendance Useful & trendy Das nützliche & trendige



Vous aimez écrire à la main, sur du vrai papier, vous aimez les carnets ? Vous cherchez le moyen de vous organiser, d'être productif, de garder des traces des petits ou grands événements de votre vie ? Vous en avez assez de vous éparpiller entre votre agenda, votre téléphone, ne savez pas où, ni comment tout rassembler ? La réponse est le Bullet Journal®.

Le Bullet Journal®, ou « Bujo », est un concept né dans l'esprit fertile d'un designer artistique new-yorkais, Ryder Carroll. Evoluant dans un monde connecté, il désire cependant demeurer en contact avec le réel, le concret et... le papier. Sa méthode d'organisation simple, devenue universelle, repose sur des listes à puces, les fameuses « bullets », permettant ainsi de capturer le temps, d'aligner, découper tous les projets, toutes les envies. Pour mieux maîtriser et personnaliser son organisation.

Do you prefer handwriting, on real paper, do you like notebooks? Are you looking for a way to organize yourself, to be productive, to keep track of small or large events in your life? Tired of scattering between your agenda, your phone, not knowing where or how to gather everything together? The answer is the Bullet Journal®.

The Bullet Journal®, nicknamed "Bujo", is a concept born in the fertile mind of New-York-based art designer Ryder Carroll. Evolving in a connected world, he nevertheless wishes to remain in contact with reality, the concrete and... paper. Its simple organization method, which has become universal, is based on bullet lists, thus making it possible to capture time, to align, to cut out all projects, all desires. In order to better control and personalize your organization.

Schreiben Sie gerne von Hand, auf echtem Papier, und lieben Sie Notizbücher? Sind Sie auf der Suche nach dem richtigen Hilfsmittel, um sich zu organisieren, produktiv zu sein und die kleinen oder großen Ereignisse in Ihrem Leben festzuhalten? Sind Sie es leid, sich zwischen Ihrem Kalender und Ihrem Handy zu verzetteln, wissen nicht, wo und wie Sie alles sammeln sollen? Die Antwort ist das Bullet Journal®.

Das Bullet Journal®, kurz "Bujo", ist ein Konzept, das dem kreativen Geist des New Yorker Kunstdesigners Ryder Carroll entsprungen ist. Auch wenn er sich in einer vernetzten Welt bewegte, wollte er dennoch mit dem Realen, Konkreten und ... dem Papier in Kontakt bleiben. Seine einfache, mittlerweile universelle Organisationsmethode basiert auf Aufzählungslisten, den berühmten "Bullets", mit denen man die Zeit einfangen, alle Projekte und Wünsche aneinanderreihen und ausschneiden kann. Auf diese Weise können Sie Ihre Organisation besser in den Griff bekommen und individuell gestalten.

Vous avez l'inspiration, nous avons le support : Le Goalbook.

Grâce au Goalbook, vous rejoindrez la devise de Ryder Carrol : « comprendre le passé, organiser le présent, définir le futur ». Ce carnet s'hybride et se fait tout-en-un, à la fois agenda, journal intime et to-do lists ! Avec pagination, index, calendriers perpétuels, rubans marque-pages, comme autant de petits détails favorisant cette précieuse approche du temps. À l'intérieur, la réglure dot autorise toute liberté de création. Et le papier Clairefontaine, unique, l'un des plus beaux papiers au monde, marquera la différence. Fabriqué en France, ce papier vélin ivoire ou blanc au velouté exceptionnel accueillera toutes les plumes et encres possibles. Sa douceur et son lissé incomparables raviront tous les amoureux du papier. Au creux de cet écran intime où se logeront notes, listes, dessins et calligraphie, vous concevrez et personnaliserez votre organisation.

Aujourd'hui, c'est toute une communauté de « Bujoteurs » et « Bujoteuses » qui s'active, prodigue astuces et conseils et partage sa passion du « Bujo » sur les réseaux sociaux et les blogs ! À vos hashtags, il ne vous reste plus désormais qu'à poster vos propres créations #Goalbook !

You have the inspiration, we have the tools: The Goalbook.

With the Goalbook, you will live up to Ryder Carrol's motto: "Understanding the past, organizing the present, defining the future". This notebook is an all-in-one, at the same time planner, diary and to-do lists! With pagination, indexes, perpetual calendars, bookmarks, as small details favoring this precious approach to time. Inside, the dot ruling allows freedom of creation. And the Clairefontaine unique paper, one of the most beautiful papers in the world, will make the difference. Made in France, this ivory or white vellum paper with its exceptional velvety touch will accommodate all possible nibs and inks. Its incomparable softness and smoothness will delight all paper lovers. In the heart of this intimate setting where notes, lists, drawings and calligraphy will be housed, you will love designing and customizing your organization.

Today, it is a whole community of "Bujoters" who are active, provide tips and advice and share their passion for the "Bujo" on social networks and blogs! Now all you have to do is post your own #Goalbook creations!

Sie haben die Inspiration, wir haben das Hilfsmittel: das Goalbook.

Mit dem Goalbook schließen Sie sich dem Motto von Ryder Carrol an: "Die Vergangenheit verstehen, die Gegenwart organisieren, die Zukunft definieren". Dieses Notizbuch ist ein Hybrid und kann alles in einem sein: Terminkalender, Tagebuch und To-Do-Listen in einem! Mit Seitenzahlen, Indexen, ewigen Kalendern und Lesezeichenbändern, die als kleine Details diese wertvolle Annäherung an die Zeit fördern. Im Inneren erlaubt die Dot-Lineatur alle kreativen Freiheiten. Das einzigartige Clairefontaine-Papier, eines der schönsten Papiersorten der Welt, wird den Unterschied ausmachen. Das in Frankreich hergestellte elfenbeinfarbene oder weiße Velinpapier mit seiner außergewöhnlich samtigen Oberfläche eignet sich für alle erdenklichen Schreibfedern und Tinten. Seine unvergleichliche Weichheit und Glätte wird alle Papierliebhaber begeistern. Im Inneren dieses vertrauten Schmuckstücks, in dem Notizen, Listen, Zeichnungen und Kalligraphie Platz finden, können Sie Ihre Organisation entwerfen und personalisieren.

Heute ist eine ganze Gemeinschaft von "Bujos" aktiv, die ihre Leidenschaft für Bujo auf sozialen Netzwerken und Blogs mit Tipps und Tricks teilen! Jetzt müssen Sie nur noch Ihre eigenen #Goalbook-Kreationen posten!



Goalbook Creation Lavis technique blanc

White Pen & inkwash Goalbook Creation

Weies Lavis Technik-Papier Goalbook Creation



Papier Lavis technique blanc
White blank Pen & Inkwash paper
Weies Lavis Technik-Papier

- Couverture rembouree rigide en simili cuir italien, fermeture lastique assortie, logos embosss, pages numrotees, index, 2 calendriers perptuels, papier Lavis technique blanc 200 g , 2 rubans marque-pages, pochette  soufflets et pages de garde blanches
- Italian leatherette hard cover, assorted elastic closure, embossed logo, numbered sheets, 6-page index, 2 perpetual calendars, 200 g white Pen & Inkwash paper, 2 ribbon bookmarks, white expanding inner pocket and front and back pages
- Fester Umschlag aus italienischem Kunstleder, passender Gummizugverschluss, geprgte Logos, nummerierte Seiten, Index, 2 ewige Kalender, 200 g weies Lavis Technik-Papier , 2 Lesezeichenbnder, Falttasche und weie Deckbltter

	A5 - 14,8 x 21	O	MINI	
	noir - black - schwarz	194150C	1	1
	taupe - taupe	194151C	1	1
	lie de vin - burgundy - Burgund	194152C	1	1
	nacarat - orangerot	194153C	1	1
	bois de rose - rosewood - Rosenholz	194154C	1	1
	saugie - sage - Salbei	194155C	1	1
	cladon - celadon - celadon	194156C	1	1
	paon - peacock - Pfau	194157C	1	1
	eau - aqua - aqua	194158C	1	1
	bleu nuit - midnight - mitternachtsblau	194159C	1	1
	coquelicot - poppy - Mohn	194160C	1	1

Film individuellement - Individually shrink-wrapped - Einzel in Folie eingeschweit

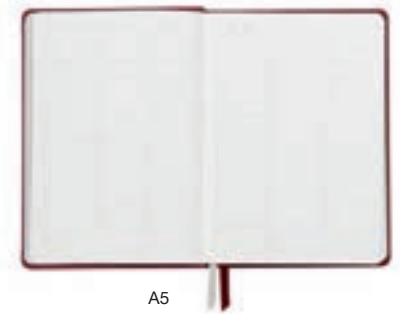

A5

11
couleurs
colors
Farben



Le Goalbook 100% création.

Outil d'organisation personnalisable par excellence, support idéal de « Bullet Journaling », le Goalbook offre désormais deux déclinaisons dédiées spécifiquement à la créativité. L'un tout en lumière, doté de papier lavis technique blanc, l'autre tout en intensité, avec ses pages de papier Maya noir, les Goalbook Creation permettent de « bujoter » de façon ultra-créative grâce aux merveilleux papiers beaux-arts Clairefontaine.

Goalbook on the creative side.

A customizable organizational tool par excellence, the ideal support for "Bullet Journaling", the Goalbook now offers two variations specifically dedicated to creativity. One is all light, with white technical wash paper, the other is all intensity, with its pages of black Maya paper, the Goalbook Creation allow you to bullet journal in an ultra-creative way thanks to the wonderful Clairefontaine fine art papers.

Das 100% kreative Goalbook.

Das Goalbook ist das ultimative personalisierbare Organisationsmittel und das ideale Medium für das "Bullet Journaling". Es gibt nun zwei Varianten, die sich speziell der Kreativität zuwenden. Das eine ist hell, mit weißem Lavis Technik-Papier, das andere intensiv, mit Seiten aus schwarzem Maya-Papier. Die Goalbooks Creation ermöglichen dank des wunderbaren Kunstdruckpapiers von Clairefontaine ein ultra-kreatives Bullet Journaling.



Le papier lavis technique blanc 200 g/m², au grain très léger, permet d'explorer une large palette de techniques ; il est particulièrement adapté aux dessins au trait, au crayon, au feutre, au fusain, à l'encre, à la gouache, au stylo graphique et à l'encre de Chine.

The 200 gsm pen & inkwash paper, with a very light grain, allows to explore a wide range of techniques; it is particularly adapted to line drawings, pencil, felt pen, charcoal, ink, gouache, graphic pen and Indian ink, and to nib work as well.

Das weiße Lavis Technik-Papier 200 g/m² mit seiner sehr leichten Körnung ermöglicht die Verwendung einer breiten Palette von Techniken; es eignet sich besonders für Strich-, Bleistift-, Filzstift-, Kohle-, Tusche-, Gouache-, Graphikstift- und China-tusche-Zeichnungen.

Goalbook Creation Maya noir

Black Maya Creation Goalbook

Schwarzes Maya Goalbook Creation



Papier Maya noir

Black Maya paper

Schwarzes Maya-Papier

- Couverture rembourdée rigide en simili cuir italien, fermeture élastique assortie, logos embossés, pages numérotées, index, 2 calendriers perpétuels, papier Maya noir 120 g, 2 rubans marque-pages, pochette à soufflets et pages de garde noires
- Italian leatherette hard cover, assorted elastic closure, embossed logo, numbered sheets, 6-page index, 2 perpetual calendars, 120 g black Maya, 2 ribbon bookmarks, black expanding inner pocket and front and back pages
- Fester Umschlag aus italienischem Kunstleder, passender Gummizugverschluss, geprägte Logos, nummerierte Seiten, Index, 2 ewige Kalender, 120 g schwarzes Maya-Papier, 2 Lesezeichenbänder, schwarze Deckblätter

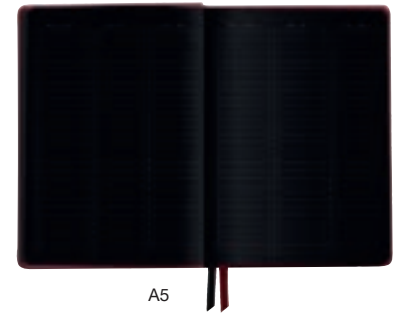

A5

11
couleurs
colors
Farben



	A5 - 14,8 x 21	dot	MINI	
	noir - black - schwarz	194440C	1	1
	taupe - taupe	194441C	1	1
	lie de vin - burgundy - Burgund	194442C	1	1
	nacarat - orangerot	194443C	1	1
	bois de rose - rosewood - Rosenholz	194444C	1	1
	saugé - sage - Salbei	194445C	1	1
	céladon - celadon - celadon	194446C	1	1
	paon - peacock - Pfau	194447C	1	1
	eau - aqua - aqua	194448C	1	1
	bleu nuit - midnight - mitternachtsblau	194449C	1	1
	coquelicot - poppy - Mohn	194450C	1	1

Filmé individuellement - Individually shrink-wrapped - Einzel in Folie eingeschweißt



Le papier Maya noir 120 g/m², teinté dans la masse, est parfaitement lisse sur les deux faces. Il se prête particulièrement bien au dessin précis au crayon, feutre, grappe liner, plume, de coloris clairs ou métalliques par exemple. Sa surface permet un séchage rapide de l'encre. Très résistant, il supporte les grattages et les gommages répétés, sans pelucher.

The 120 gsm black Maya paper, deep dyed, is perfectly smooth on both sides. It lends itself particularly well to precise drawing with pencil, felt-tip pen, graph liner, fountain pen - light or metallic colors for example. Its surface allows a fast drying of the ink. Very resistant, it can withstand repeated scratching and erasing, without linting.

Das schwarze, voll durchgefärbte Maya-Papier (120 g/m²) ist auf beiden Seiten glatt. Es eignet sich besonders gut für präzise Zeichnungen mit Bleistift, Filzstift, Graphikliner oder Feder, z. B. in hellen oder metallischen Farben. Seine Oberfläche lässt die Tinte schnell trocknen. Es ist sehr widerstandsfähig und hält wiederholtem Kratzen und Radieren stand, ohne zu fusseln.



RHODIARAMA

Photos non contractuelles - Photos are not contractually binding - Bild vertraglich nicht bindend

Goalbook couverture souple

Softcover Goalbook

Goalbook mit weichem Umschlag

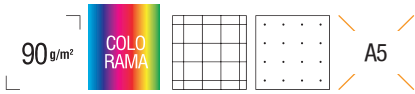

- Couverture souple en simili cuir italien, dos carré collé, logos embossés, fermeture élastique orange, 240 pages non perforées (224 pages numérotées, 6 pages d'index, 2 calendriers perpétuels), papier vélin velouté ivoire 90 g, porte-crayon, 2 rubans marque-pages, pochette à soufflets et pages de garde orange
- Italian leatherette soft cover, glued spine, embossed logos, orange elastic closure, 120 non microperforated sheets (112 numbered sheets, 6-page index, 2 perpetual calendars), 90 g ivory brushed vellum paper, pen loop, 2 ribbon bookmarks orange expanding inner pocket and front and back pages
- Weicher Umschlag aus italienischem Kunstleder, geklebter Rücken, geprägte Logos, orangefarbener Gummizugverschluss, 120 ungelochte Bögen (112 nummerierte Seiten, 6 Indexseiten, 2 ewige Kalender), elfenbeinfarbenes, samtweiches Velinpapier 90 g, Bleistifthalter, 2 Lesezeichenbänder, Falttasche und orangefarbene Deckblätter



Papier vélin velouté ivoire ou blanc 90 g - Couverture simili cuir 90 g ivory or white brushed vellum paper - Leatherette cover
 90 g Velinpapier elfenbein oder weiß - Deckel aus italienischem Kunstleder

A5 - 14,8 x 21	papier ivoire ivory paper elfenbeinfarbenes Papier			papier blanc white paper weißes Papier			MINI	
	5/5	dot	dot	dot	dot	dot		
or - gold - gold	-	117811C	20	-	1	1		
cuivre - copper - Kupfer	-	117812C	20	-	1	1		
bronze- bronze - bronze	-	117813C	20	-	1	1		
titane - titanium - Titan	-	117814C	20	-	1	1		
argent - silver - silber	117761C	20	117741C	20	117570C	20	1	1
blanc - white - weiß	-	117815C	20	-	1	1		
noir - black - schwarz	117762C	20	117742C	20	117571C	20	1	1
chocolat - chocolate - schokobraun	117763C	40	117743C	20	117572C	20	1	1
taupe - taupe	117764C	20	117744C	20	117573C	20	1	1
beige - beige	117765C	40	117745C	20	117574C	20	1	1
lie de vin - burgundy - Burgund	-	117800C	20	-	1	1		
nacarat - orangerot	-	117801C	20	-	1	1		
bois de rose - rosewood - Rosenholz	-	117802C	20	-	1	1		
touche de rose - rose smoke - Rosendunst	-	117803C	20	-	1	1		
anis - anise - anis	117766C	40	117746C	20	117575C	20	1	1
sauge - sage - Salbei	-	117804C	20	-	1	1		
céladon - celadon - celadon	-	117805C	20	-	1	1		
paon - peacock - Pfau	-	117806C	20	-	1	1		
eau - aqua - aqua	-	117807C	20	-	1	1		
turquoise - turquoise - türkis	117767C	20	117747C	20	117576C	20	1	1
bleu nuit - midnight - mitternachtsblau	-	117808C	20	-	1	1		
saphir - sapphire - saphirblau	117768C	20	117748C	20	117577C	20	1	1
iris - iris	117769C	40	117749C	20	117578C	20	1	1
violet - purple - violett	117770C	40	117750C	20	117579C	20	1	1
lilas - lilac - Lilie	117771C	40	117751C	20	117580C	20	1	1
fuchsia - Fuchsie	-	117809C	20	-	1	1		
framboise - raspberry - Himbeere	117772C	20	117752C	20	117581C	20	1	1
coquelicot - poppy - Mohn	117773C	40	117753C	20	117582C	20	1	1
corail - coral - Koralle	-	117810C	20	-	1	1		
tangerine - tangerin - Mandarine	117774C	20	117754C	20	117583C	20	1	1
orange - orange	117775C	40	117755C	20	117584C	20	1	1
jonquille - daffodil - Narzisse	117776C	40	117756C	20	117585C	20	1	1
Filmé individuellement - Individually shrink-wrapped - Einzeln in Folie eingeschweißt								
Présentoir/display 32 x A5	-	117746PC	32	-				

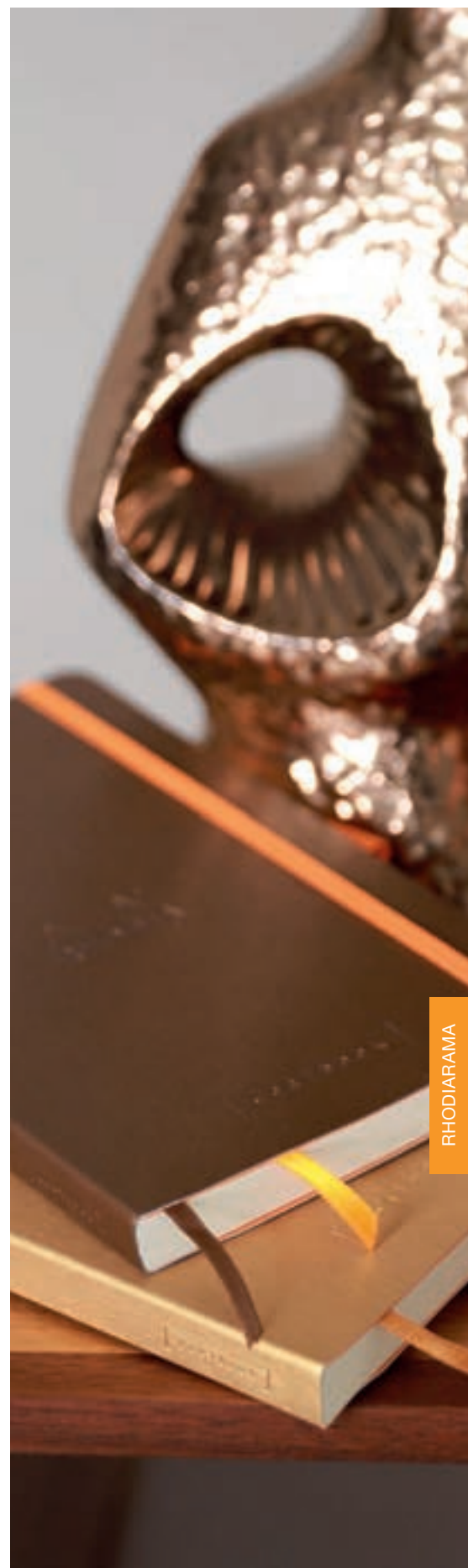

RHODIARAMA

Goalbook rembourré rigide

Hardcover Goalbook

Goalbook mit festem Umschlag

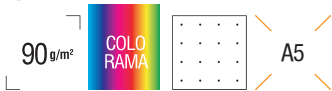

- Couverture rembourrée rigide en simili cuir italien, fermeture élastique orange, logos embossés, 240 pages non perforées (224 pages numérotées, 6 pages d'index, 2 calendriers perpétuels), papier vélin velouté ivoire ou blanc 90 g, porte-crayon, 3 rubans marque-pages (1 orange et 2 assortis), pochette à soufflets et pages de garde orange.
- Italian leatherette hard cover, orange elastic closure, embossed logos, 120 non microperforated sheets, (112 numbered sheets, 6-page index, 2 perpetual calendars), 90 g ivory or white brushed vellum paper, pen loop, 3 ribbon bookmarks (1 orange, 2 assorted), orange expanding inner pocket and front and back pages.
- Fester Umschlag aus italienischem Kunstleder, orangefarbener Gummizugverschluss, geprägte Logos, 120 ungelochte Seiten (112 nummerierte Seiten, 6 Indexseiten, 2 ewige Kalender), elfenbeinfarbenes oder weißes Velinpapier 90 g, Bleistifthalter, 3 Lesezeichenbänder (1 oranges und 2 farblich passende), Falttasche und orangefarbene Deckblätter.



	papier ivoire ivory paper elfenbeinfarbenes Papier		papier blanc white paper weißes Papier		MINI	
A5 - 14,8 x 21	dot		dot			
argent - silver - silber	118771C	20	118570C	20	1	1
noir - black - schwarz	118772C	20	118571C	20	2	1
chocolat - chocolate - schokobraun	118773C	20	118572C	16	2	1
taupe - taupe	118774C	20	118573C	16	2	1
beige - beige	118775C	20	118574C	16	2	1
anis - anise green - anisgrün	118776C	20	118575C	16	2	1
turquoise - turquoise blue - türkis	118777C	20	118576C	20	2	1
saphir - sapphire blue - saphirblau	118778C	20	118577C	20	2	1
iris - iris	118779C	20	118578C	16	2	1
violet - purple - violett	118780C	20	118579C	20	2	1
lilas - lilac - Lilie	118781C	20	118580C	16	2	1
framboise - raspberry - Himbeere	118782C	20	118581C	16	2	1
coquelicot - poppy - Mohn	118783C	20	118582C	16	2	1
tangerine - tangerin - Mandarine	118784C	32	118583C	16	2	1
orange - orange	118785C	20	118584C	20	2	1
jonquille - daffodil yellow - Narzisse	118786C	20	118585C	16	2	1



Filmé individuellement - Individually shrink-wrapped - Einzel in Folie eingeschweißt

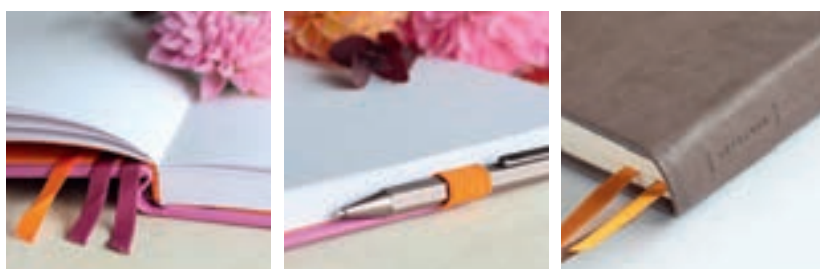

Papier vélin velouté ivoire ou blanc 90 g - Couverture simili cuir 90 g ivory or white brushed vellum paper - Leatherette cover
90 g Velinpapier elfenbein oder weiß - Deckel aus italienischem Kunstleder

Doté de l'incomparable papier vélin velouté Clairefontaine, le Goalbook est l'outil idéal pour organiser son quotidien, ses objectifs et ne rien oublier grâce à ses pages numérotées, tables de contenu et d'indexation, et calendriers perpétuels pré-imprimés. De quoi devenir le chouchou des passionné(e)s de «Bullet Journaling»® !

Thanks to 240 numbered pages of Clairefontaine 90 g French-milled paper, contents and indexing pages and pre-printed perpetual calendars, the Goalbook is perfect to organize your days, manage your goals and make sure you don't forget anything. That makes it the «Bullet Journaling»® fans' favorite!

Das Goalbook mit dem unvergleichlichen samtweichen Velinpapier von Clairefontaine ist das ideale Arbeitsmittel, um seinen Alltag und seine Zielvorgaben zu organisieren, dank der nummerierten Seiten, der Inhalts- und Indextabellen und der vorgedruckten ewigen Kalender nichts zu vergessen. Damit wird es zum Liebling aller Liebhaber des «Bullet Journaling»®!



Papier vélin velouté ivoire ou blanc 90 g - Couverture simili cuir 90 g ivory or white brushed vellum paper - Leatherette cover
90 g Velinpapier elfenbein oder weiß - Deckel aus italienischem Kunstleder

Set de 2 minibooks

Set of 2 mini notebooks

2er Set Mini-Notizbücher



- Couverture souple en simili cuir italien, dos carré collé, logo embossé, 64 pages, papier vélin velouté ivoire 90 g
- Italian leatherette soft cover, glued spine, embossed logo, 32 sheets, 90 g ivory brushed vellum paper
- Weicher Umschlag aus italienischem Kunstleder, geleimter Rücken, geprägtes Logo, 32 Seiten, elfenbeinfarbenes samtweiches Velinpapier 90 g



7 x 10,5		L	☐
	argent + noir - silver + black - silber + schwarz	117201C	5
	chocolat + taupe - chocolate + taupe - schokobraun + taupe	117203C	5
	beige + anis - beige + anise green - beige + anisgrün	117205C	5
	turquoise + saphir - turquoise blue + sapphire blue - türkis + saphirblau	117207C	5
	iris + violet - iris + purple - iris + violett	117209C	5
	lilas + framboise - lilac + raspberry - Lilie + Himbeere	117211C	5
	coquelicot + tangerine - poppy + tangerine - Mohn + Mandarine	117213C	5
	orange + jonquille - orange + daffodil yellow - orange + Narzisse	117215C	5

Set sous film - Filmed set - Folienset

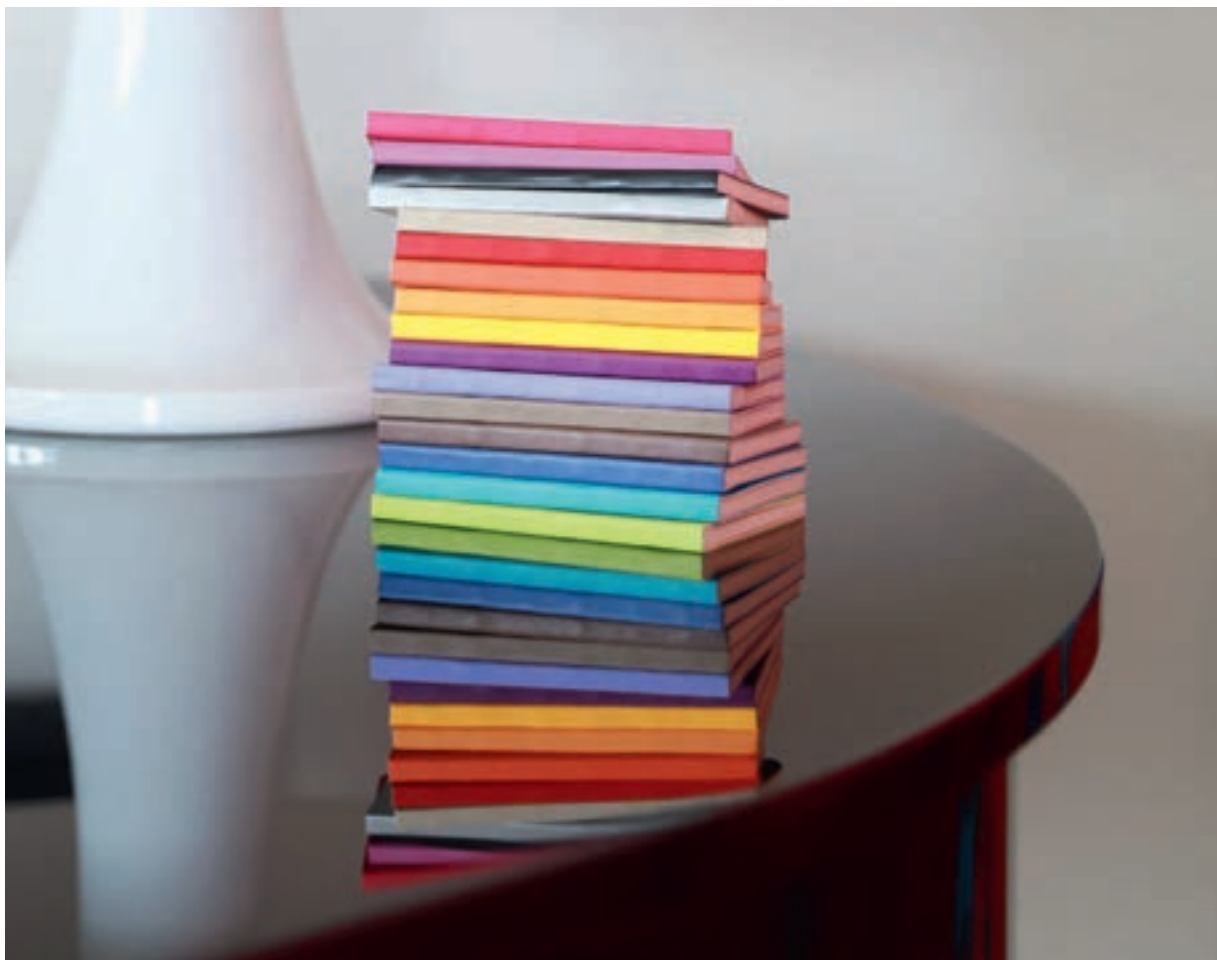

Carnet souple A6

A6 softcover notebook

Notizbuch A6 mit weichem Umschlag



- Couverture en simili cuir italien, dos carré collé, logo embossé, fermeture élastique orange, 144 pages, papier vélin velouté ivoire 90 g, ruban marque-page, pochette à soufflets et pages de garde orange
- Italian leatherette soft cover, glued spine, embossed logo, orange elastic closure, 72 sheets, 90 g ivory brushed vellum paper, orange ribbon bookmark, expanding inner pocket and front and back pages
- Umschlag aus italienischem Kunstleder, geleimter Rücken, geprägtes Logo, orangefarbener Gummizugverschluss, 72 Blätter, 90 g elfenbeinfarbenes, samtweiches Velinpapier, Lesezeichenband, Falttasche und orangefarbene Deckblätter



A6

		A6 - 10,5 x 14,8		MINI	📦	📦
		L	dot			
	argent - silver - silber	117301C	117351C	1	1	40
	noir - black - schwarz	117302C	117352C	1	1	40
	chocolat - chocolate - schokobraun	117303C	117353C	1	1	40
	taupe - taupe	117304C	117354C	1	1	40
	beige - beige	117305C	117355C	1	1	40
	anis - anise green - anisgrün	117306C	117356C	1	1	40
	turquoise - turquoise blue - türkis	117307C	117357C	1	1	40
	saphir - sapphire blue - saphirblau	117308C	117358C	1	1	40
	iris - iris		117359C	1	1	40
	violet - purple - violett	117310C	117360C	1	1	40
	lilas - lilac - Lilie	117311C	117361C	1	1	40
	framboise - raspberry - Himbeere	117312C	117362C	1	1	40
	coquelicot - poppy - Mohn	117313C	117363C	1	1	40
	tangerine - tangerin - Mandarine	117314C	117364C	1	1	40
	orange - orange	117315C	117365C	1	1	40
	jonquille - daffodil yellow - Narzisse	117316C	117366C	1	1	40



Filmé individuellement - Individually shrink-wrapped - Einzeln in Folie eingeschweißt



Papier vélin velouté ivoire ou blanc 90 g - Couverture simili cuir 90 g ivory or white brushed vellum paper - Leatherette cover
90 g Velinpapier elfenbein oder weiß - Deckel aus italienischem Kunstleder

Carnet souple A5

A5 softcover notebook

Notizbuch A5 mit weichem Umschlag



- Couverture en simili cuir italien, dos carré collé, logo embossé, fermeture élastique orange, 160 pages, papier vélin velouté ivoire 90 g, ruban marque-page, pochette à soufflets et pages de garde orange
- Italian leatherette soft cover, glued spine, embossed logo, orange elastic closure, 80 sheets, 90 g ivory brushed vellum paper, orange ribbon book-mark, orange expanding inner pocket and front and back pages
- Umschlag aus italienischem Kunstleder, geleimter Rücken, geprägtes Logo, orangefarbener Gummizugverschluss, 80 Blätter, elfenbeinfarbenes, samtweiches Velinpapier 90 g, Lesezeichenband, Faleltasche und orange-farbene Deckblätter



	A5 - 14,8 x 21		MINI	📦	📦
	L	dot			
or - gold - gold	117382C	117476C	1	1	40
cuirre - copper - Kupfer	117383C	117477C	1	1	40
bronze- bronze - bronze	117384C	117478C	1	1	40
titane - titanium - Titan	117385C	117479C	1	1	40
argent - silver - silber	117401C	117451C	1	1	40
blanc - white - weiß	117386C	117480C	1	1	40
noir - black - schwarz	117402C	117452C	1	1	40
chocolat - chocolate - schokobraun	117403C	117453C	1	1	40
taupe - taupe	117404C	117454C	1	1	40
beige - beige	117405C	117455C	1	1	40
lie de vin - burgundy - burgund	117370C	117436C	1	1	40
nacarat - orangerot	117371C	117437C	1	1	40
bois de rose - rosewood - Rosenholz	117372C	117438C	1	1	40
touche de rose - rose smoke - Rosendunst	117373C	117439C	1	1	40
anis - anise - anis	117406C	117456C	1	1	40
sauge - sage - Salbei	117374C	117440C	1	1	40
céladon - celadon - celadon	117375C	117441C	1	1	40
paon - peacock - Pfau	117376C	117442C	1	1	40
eau - aqua - aqua	117377C	117443C	1	1	40
turquoise - turquoise - türkis	117407C	117457C	1	1	40
bleu nuit - midnight - mitternachtsblau	117378C	117444C	1	1	40
saphir - sapphire - saphirblau	117408C	117458C	1	1	40
iris - iris	117409C	117459C	1	1	40
violet - purple - violett	117410C	117460C	1	1	40
lilas - lilac - Lilie	117411C	117461C	1	1	40
fuchsia - Fuchsie	117379C	117445C	1	1	40
framboise - raspberry - Himbeere	117412C	117462C	1	1	40
coquelicot - poppy - Mohn	117413C	117463C	1	1	40
corail - coral - Koralle	117380C	117446C	1	1	40
tangerine - tangerin - Mandarine	117414C	117464C	1	1	40
orange - orange	117415C	117465C	1	1	40
jonquille - daffodil - Narzisse	117416C	117466C	1	1	40
Présentoir/display 44 x A5	117370PC	117436PC			44



Filmé individuellement - Individually shrink-wrapped - Einzeln in Folie eingeschweißt

Papier vélin velouté ivoire ou blanc 90 g - Couverture simili cuir 90 g ivory or white brushed vellum paper - Leatherette cover
 90 g Velinpapier elfenbein oder weiß - Deckel aus italienischem Kunstleder



Hissez fièrement les couleurs de vos carnets souples Rhodiarama, ils ont une allure folle !
Passe-partout, nomade ou maxi-compagnon, c'est simple, on les veut tous !

Such style! Hoist the colors of your Rhodiarama softcover notebooks, your perfect companions for every moment in life.

*Hissen Sie stolz die Farben Ihrer biegsamen Rhodiarama-Notizbücher, sie sehen einfach toll aus!
Ob Passepartout, Nomade oder Maxi-Begleiter, wir wollen sie alle!*



Papier vélin velouté ivoire ou blanc 90 g - Couverture simili cuir 90 g ivory or white brushed vellum paper - Leatherette cover
90 g Velinpapier elfenbein oder weiß - Deckel aus italienischem Kunstleder

Cahier souple 19x25 cm

B5 softcover notebook

Heft mit weichem Umschlag 19x25 cm



- Couverture en simili cuir italien, dos carré collé, logo embossé, fermeture élastique orange, 160 pages, papier vélin velouté ivoire 90 g, ruban marque-page, pochette à soufflets et pages de garde orange
- Italian leatherette soft cover, glued spine, embossed logo, orange elastic closure, 80 sheets, 90 g ivory brushed vellum paper, orange ribbon bookmark, orange expanding inner pocket and front and back pages
- Umschlag aus italienischem Kunstleder, geleimter Rücken, geprägtes Logo, orangefarbener Gummizugverschluss, 80 Blätter, elfenbeinfarbenes, samtweiches Velinpapier 90 g, Lesezeichenband, Falttasche und orangefarbene Deckblätter



19x25 cm / B5

19 x 25 / B5	L	dot	MINI
argent - silver - silber	117501C	117551C	1
noir - black - schwarz	117502C	117552C	1
chocolat - chocolate - schokobraun	117503C	117553C	1
taupe - taupe	117504C	117554C	1
beige - beige	117505C	117555C	1
anis - anise green - anisgrün	117506C	117556C	1
turquoise - turquoise blue - türkis	117507C	117557C	1
saphir - sapphire blue - saphirblau	117508C	117558C	1
iris - iris	117509C	117559C	1
violet - purple - violett	117510C	117560C	1
lilas - lilac - Lilie	117511C	117561C	1
framboise - raspberry - Himbeere	117512C	117562C	1
coquelicot - poppy - Mohn	117513C	117563C	1
tangerine - tangerin - Mandarine	117514C	117564C	1
orange - orange	117515C	117565C	1
jonquille - daffodil yellow - Narzisse	117516C	117566C	1



Filmé individuellement - Individually shrink-wrapped - Einzeln in Folie eingeschweißt



Papier vélin velouté ivoire ou blanc 90 g - Couverture simili cuir 90 g ivory or white brushed vellum paper - Leatherette cover
90 g Velinpapier elfenbein oder weiß - Deckel aus italienischem Kunstleder

Cahier souple A4+

A4+ softcover notebook

Heft mit weichem Umschlag A4+



- Couverture en simili cuir italien, dos carré collé, logo embossé, fermeture élastique orange, 160 pages, papier vélin velouté ivoire 90 g, ruban marque-page, pochette à soufflets et pages de garde orange

- Italian leatherette soft cover, glued spine, embossed logo, orange elastic closure, 80 sheets, 90 g ivory brushed vellum paper, orange ribbon bookmark, orange expanding inner pocket and front and back pages

- Umschlag aus italienischem Kunstleder, geleimter Rücken, geprägtes Logo, orangefarbener Gummizugverschluss, 80 Blätter, elfenbeinfarbenes, samtweiches Velinpapier 90 g, Lesezeichenband, Falttasche und orangefarbene Deckblätter



A4+

A4+ - 22 x 29,7	L + C	MINI		
argent - silver - silber	117701C	1	1	10
noir - black - schwarz	117702C	1	1	10
chocolat - chocolate - schokobraun	117703C	1	1	10
taupe - taupe	117704C	1	1	10
beige - beige	117705C	1	1	10
anis - anise green - anisgrün	117706C	1	1	10
turquoise - turquoise blue - türkis	117707C	1	1	10
saphir - sapphire blue - saphirblau	117708C	1	1	10
iris - iris	117709C	1	1	10
violet - purple - violett	117710C	1	1	10
lilas - lilac - Lilie	117711C	1	1	10
framboise - raspberry - Himbeere	117712C	1	1	10
coquelicot - poppy - Mohn	117713C	1	1	10
tangerine - tangerin - Mandarine	117714C	1	1	10
orange - orange	117715C	1	1	10
jonquille - daffodil yellow - Narzisse	117716C	1	1	10



Filmé individuellement - Individually shrink-wrapped - Einzeln in Folie eingeschweißt



Papier vélin velouté ivoire ou blanc 90 g - Couverture simili cuir 90 g ivory or white brushed vellum paper - Leatherette cover
90 g Velinpapier elfenbein oder weiß - Deckel aus italienischem Kunstleder

Carnet piqûre textile A5

A5 sewn spine notebook

A5-Notizbuch mit genähtem Rücken

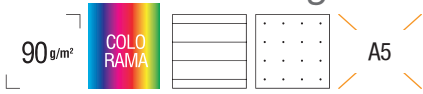

- Couverture souple en simili cuir italien, piqûre textile orange, logo embossé, 64 pages, papier vélin velouté ivoire 90 g, pages de garde orange
- Italian leatherette swen spine soft cover, embossed logo, 32 sheets, 90 g ivory brushed vellum paper, orange front and back pages
- Weicher Umschlag aus italienischem Kunstleder, orangefarbene Textilnaht, geprägtes Logo, 32 Blätter, 90 g samtweiches Velinpapier in Elfenbein, orangefarbene Deckblätter

	A5 - 14,8 x 21	L	dot	MINI		
	argent - silver - silber	116401C	116451C	2	1	60
	noir - black - schwarz	116402C	116452C	2	1	60
	chocolat - chocolate - schokobraun	116403C	116453C	2	1	60
	taupe - taupe	116404C	116454C	2	1	60
	beige - beige	116405C	116455C	2	1	60
	anis - anise green - anisgrün	116406C	116456C	2	1	60
	turquoise - turquoise blue - türkis	116407C	116457C	2	1	60
	saphir - sapphire blue - saphirblau	116408C	116458C	2	1	60
	iris - iris	116409C	116459C	2	1	60
	violet - purple - violett	116410C	116460C	2	1	60
	lilas - lilac - Lilie	116411C	116461C	2	1	60
	framboise - raspberry - Himbeere	116412C	116462C	2	1	60
	coquelicot - poppy - Mohn	116413C	116463C	2	1	60
	tangerine - tangerin	116414C	116464C	2	1	60
	orange - orange	116415C	116465C	2	1	60
	jonquille - daffodil yellow - narzisse	116416C	116466C	2	1	60



Filmé individuellement - Individually shrink-wrapped - Einzeln in Folie eingeschweißt

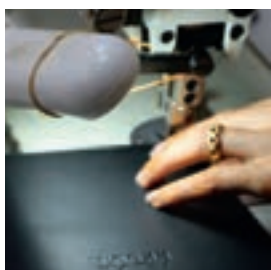

piqûre textile orange
orange swen spine
orangefarbener genähter Rücken



Papier vélin velouté ivoire ou blanc 90 g - Couverture simili cuir 90 g ivory or white brushed vellum paper - Leatherette cover
90 g Velinpapier elfenbein oder weiß - Deckel aus italienischem Kunstleder

Succombez au charme de la couverture veloutée et à l'authenticité de la finition cousue main des carnets à piqûre textile Rhodiarama !

With their velvet-smooth covers and authentic hand-stitched finish, the Rhodiarama sewn spine notebooks are quite simply irresistible!

Erliegen Sie dem Charme des samtweichen Einbands und der authentischen, handgenähten Verarbeitung der Rhodiarama-Notizbücher mit Textilheftung!



Papier vélin velouté ivoire ou blanc 90 g - Couverture simili cuir 90 g ivory or white brushed vellum paper - Leatherette cover
90 g Velinpapier elfenbein oder weiß - Deckel aus italienischem Kunstleder

Meeting Book

Meeting Book

Meetingbuch



- Couverture souple en simili cuir italien, dos carré collé, logos embossés, fermeture élastique orange, 160 pages microperforées, papier vélin velouté blanc 90 g, calendrier perpétuel, porte-crayon, ruban marque-page, pochette à soufflets et pages de garde orange
- Italian leatherette soft cover, glued spine, embossed logos, orange elastic closure, 80 microperforated sheets, 90 g white brushed vellum paper, perpetual calendar, pen loop, orange ribbon bookmark, expanding inner pocket and front and back pages
- Weicher Umschlag aus italienischem Kunstleder, geleimter Rücken, geprägte Logos, orangefarbener Gummizugverschluss, 80 mikroperforierte Blätter, weißes samtweiches Velinpapier 90 g, ewiger Kalender, Bleistifthalter, Lesezeichenband, Falttasche und orangefarbene Deckblätter



	A5+ - 16 x 21	meeting	MINI		
	argent - silver - silber	117781C	2	1	32
	noir - black - schwarz	117782C	2	1	32
	chocolat - chocolate - schokobraun	117783C	2	1	32
	taupe - taupe	117784C	2	1	32
	beige - beige	117785C	2	1	44
	anis - anise green - anisgrün	117786C	2	1	32
	turquoise - turquoise blue - türkis	117787C	2	1	32
	saphir - sapphire blue - saphirblau	117788C	2	1	32
	iris - iris	117789C	2	1	32
	violet - purple - violett	117790C	2	1	32
	lilas - lilac - Lilie	117791C	2	1	44
	framboise - raspberry - Himbeere	117792C	2	1	32
	coquelicot - poppy - Mohn	117793C	2	1	32
	tangerine - tangerin	117794C	2	1	44
	orange- orange	117795C	2	1	32
	jonquille - daffodil yellow - Narzisse	117796C	2	1	32
Filmé individuellement - Individually shrink-wrapped - Einzeln in Folie eingeschweißt					
Présentoir de 20 - display of 20 x A5+ - 20er Display			117021C*	20	



* jusqu'à épuisement des stocks - while stocks last
solange der Vorrat reicht

Papier vélin velouté ivoire ou blanc 90 g - Couverture simili cuir 90 g ivory or white brushed vellum paper - Leatherette cover
90 g Velinpapier elfenbein oder weiß - Deckel aus italienischem Kunstleder

Un cahier de synthèse, permettant de revisiter d'un coup d'œil les tenants et aboutissants d'une réunion, toutes les notes étant astucieusement regroupées sur une même feuille !

A synthesis booklet, allowing you to revisit at one glance the ins and outs of a meeting, all the notes being cleverly gathered on the same sheet!

Ein Syntheseheft, mit dem Sie auf einen Blick noch einmal die wichtigsten Ereignisse einer Besprechung durchgehen können, wobei alle Notizen clever auf einem Blatt zusammengefasst sind!



Papier vélin velouté ivoire ou blanc 90 g - Couverture simili cuir 90 g ivory or white brushed vellum paper - Leatherette cover
 90 g Velinpapier elfenbein oder weiß - Deckel aus italienischem Kunstleder

RHODIARAMA

Photos non contractuelles - Photos are not contractually binding - Bild vertraglich nicht bindend

Perpetual



- Couverture souple en simili cuir italien, dos carré collé, logos embossés, fermeture élastique orange, 128 pages, papier vélin velouté ivoire 90 g, 2 pages d'index, calendriers perpétuels, page de gauche : planning hebdomadaire non daté / page de droite : grille de prise de notes DOT + 10 pages de notes libres DOT, coins marque-page détachables, pochette à soufflets et pages de garde orange

- Italian leatherette soft cover, glued spine, embossed logos, orange elastic closure, 64 sheets, 90 g ivory brushed vellum paper, 2-page index, perpetual calendars, left: non-dated weekly schedule page / right: DOT grid page for notes + 10 extra DOT pages for notes, microperforated bottom corners, orange expanding inner pocket and front and back pages

- Weicher Umschlag aus italienischem Kunstleder, geleimter Rücken, geprägte Logos, orangefarbener Gummizugverschluss, 64 Blätter, elfenbeinfarbenes samtweiches Velinpapier 90 g, 2 Indexseiten, ewiger Kalender, linke Seite: undatierter Wochenplan / rechte Seite: DOT-Notizraster + 10 Seiten freie DOT-Notizen, abtrennbare Lesezeichen-Ecken, Falttasche und orangefarbene Deckblätter.



A5 - 14,8 x 21	perpetual	MINI		
argent - silver - silber	117181C	2	1	40
noir - black - schwarz	117182C	2	1	40
chocolat - chocolate - schokobraun	117183C	2	1	40
taupe - taupe	117184C	2	1	40
beige - beige	117185C	2	1	40
anis - anise green - anisgrün	117186C	2	1	40
turquoise - turquoise blue - türkis	117187C	2	1	40
saphir - sapphire blue - saphirblau	117188C	2	1	40
iris - iris	117189C	2	1	40
violet - purple - violett	117190C	2	1	40
lilas - lilac - Lilie	117191C	2	1	40
framboise - raspberry - Himbeere	117192C	2	1	40
coquelicot - poppy - Mohn	117193C	2	1	40
tangerine - tangerin	117194C	2	1	40
orange - orange	117195C	2	1	40
jonquille - daffodil yellow - Narzisse	117196C	2	1	40



Un agenda perpétuel, c'est un agenda que l'on débute quand on le souhaite et qui ne périmé pas ! Il permet une organisation personnalisée: parfait quand le planning annuel n'est tributaire ni de l'année civile ni de l'année scolaire.

A perpetual planner is a planner that you start whenever you want and that does not expire! It allows a personalized organization - perfect when the annual planning is not dependent on the calendar year or the school year.

Ein ewiger Terminkalender ist ein Terminkalender, den man beginnt, wann man möchte und, der nicht ausläuft! Er ermöglicht eine individuelle Organisation: Perfekt, wenn die Jahresplanung weder vom Kalender- noch vom Schuljahr abhängig ist.

Filmé individuellement - Individually shrink-wrapped - Einzeln in Folie eingeschweißt

présentoir de 22 - display of 22 x A5 - 22er Display 117740C* 22

* jusqu'à épuisement des stocks - while stocks last - solange der Vorrat reicht

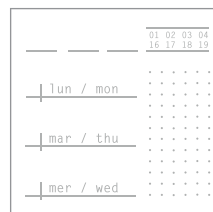

Une semaine ouverte page de gauche pour s'organiser et planifier, jongler entre RDV professionnels et personnels ; une généreuse grille de points sur la page de droite pour laisser libre cours à ses idées, réflexions, to-do lists et autres annotations.

An open week on the left page to organize and plan, juggle between professional and personal appointments ; on the right page a generous dot grid for you to give free rein to your ideas, to-do lists and other annotations.

Eine offene Woche auf der linken Seite, um zu organisieren und zu planen, um zwischen beruflichen und persönlichen Terminen zu jonglieren; ein großzügiges Punkteraster auf der rechten Seite, um seinen Ideen, Überlegungen, To-do-Listen und anderen Anmerkungen freien Lauf zu lassen.



Photos non contractuelles - Photos are not contractually binding - Bild vertraglich nicht bindend

RHODIARAMA

Webnotebook



9x14 cm

- Couverture rembourrée rigide en simili cuir italien, logo embossé, fermeture élastique assortie, 192 pages, papier vélin velouté ivoire 90 g, ruban marque-page et pochette à soufflet assortis
- Italian leatherette hardcover notebook, embossed logo, assorted elastic closure, 96 sheets, 90 g ivory brushed vellum paper, assorted ribbon bookmark and expanding inner pocket
- *Fester Umschlag aus italienischem Kunstleder mit geprägtem Logo, passendem Gummizugverschluss, 96 Blätter, elfenbeinfarbenes, samtweiches Velinpapier 90 g, passendes Lesezeichenband und Falttasche*



A5

9 x 14		O	L	dot	MINI		
	orange	118078C	118068C	118568C	2	1	40
	noir - black - schwarz	118079C	118069C	118569C	2	1	40
	argent - silver - silber		118067C	118567C	2	1	40
A5 - 14 x 21		O	L	dot	MINI		
	orange	118668C	118608C	118768C	2	1	*
	noir - black - schwarz	118669C	118609C	118769C	2	1	*
	argent - silver - silber		118607C	118767C	2	1	*
A4 - 21 x 29,7		O	L	dot	MINI		
	orange	118468C	118368C	118868C	2	1	10
	noir - black - schwarz		118369C	118869C	2	1	10



A4

Filmé individuellement - Individually shrink-wrapped - Einzeln in Folie eingeschweißt

* Nous consulter - Consult us - Kontaktieren Sie uns

RHODIARAMA



logo embossé
embossed logo

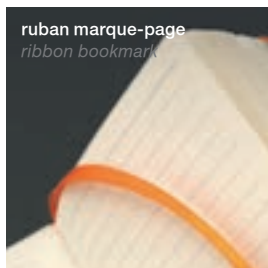

ruban marque-page
ribbon bookmark



fermeture élastique
elastic closure

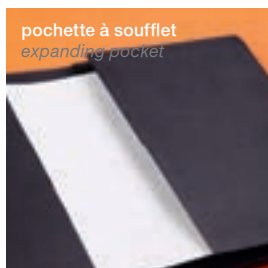

pochette à soufflet
expanding pocket



Papier vélin velouté ivoire ou blanc 90 g - Couverture simili cuir 90 g ivory or white brushed vellum paper - Leatherette cover
90 g Velinpapier elfenbein oder weiß - Deckel aus italienischem Kunstleder

Webnotebook paysage

Landscape

Webnotizbuch Querformat



• Couverture rembourrée rigide en simili cuir italien, logo embossé, fermeture élastique assortie, 192 pages, papier vélin velouté ivoire 90 g, ruban marque-page et pochette à soufflet assortis

• Italian leatherette hardcover notebook, embossed logo, assorted elastic closure, 96 sheets, 90 g ivory brushed vellum paper, assorted ribbon bookmark and expanding inner pocket

• Fester Einband aus italienischem Kunstleder, geprägtes Logo, passender Gummizugverschluss, 96 Blätter, elfenbeinfarbenes, samtweiches Velinpapier 90 g, passendes Lesezeichenband und Falttasche

	14 x 11	O	L	dot	MINI		
	orange	118028C*	118038C*		2	1	40
	noir - black - schwarz	118029C			2	1	40
	A5 - 21 x 14	O	L	dot	MINI		
	orange	118178C	118248C*		2	1	40
	noir - black - schwarz	118179C		118049C	2	1	**

Filmé individuellement - Individually shrink-wrapped - Einzeln in Folie eingeschweißt

*jusqu'à épuisement des stocks - while stocks last - solange der Vorrat reicht

** Nous consulter - Consult us - Kontaktieren Sie uns



14x11 cm



A5



Papier vélin velouté ivoire ou blanc 90 g - Couverture simili cuir 90 g ivory or white brushed vellum paper - Leatherette cover
90 g Velinpapier elfenbein oder weiß - Deckel aus italienischem Kunstleder

Carnet rigide

Hardcover notebook

Notizbuch mit festem Umschlag

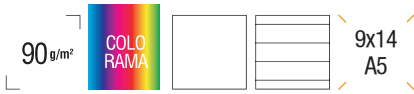

- Couverture rembourrée rigide en simili cuir italien, logo embossé, fermeture élastique orange, 192 pages, papier vélin velouté ivoire 90 g, ruban marque-page, pochette à soufflets et pages de garde orange
- Italian leatherette hard cover, embossed logo, orange elastic closure, 96 sheets, 90 g ivory brushed vellum paper, orange ribbon bookmark, expanding inner pocket and front and back pages
- Fester Umschlag aus italienischem Kunstleder, geprägtes Logo, orangefarbener Gummizugverschluss, 96 Blätter, elfenbeinfarbenes, samtweiches Velinpapier 90 g, Lesezeichenband, Falttasche und orangefarbene Deckblätter



Filmé individuellement - Individually shrink-wrapped - Einzeln in Folie eingeschweißt

	A5 - 14,8 x 21	O	L	Mini
	noir - black - schwarz		118742C	28 2 1
	chocolat - chocolate - schokobraun		118743C	28 2 1
	taupe - taupe	118724C*	118744C	40 28 2 1
	beige - beige	118725C*	118745C	40 28 2 1
	anis - anise - anis	118726C*	118746C	40 28 2 1
	turquoise - turquoise - türkis		118747C	28 2 1
	saphir - sapphire - saphirblau	118728C*	118748C	28 28 2 1
	iris - iris	118729C*		40 2 1
	violet - purple - violett	118730C*	118750C	40 28 2 1
	lilas - lilac - Lilie	118731C*	118751C	40 28 2 1
	framboise - raspberry - Himbeere		118752C	28 2 1
	coquelicot - poppy - Mohn		118753C	28 2 1
	tangerine - tangerin	118734C*		40 2 1
	orange - orange	118735C*		40 2 1
	jonquille - daffodil - Narzisse	118736C*		40 2 1

	9 x 14	O	L	Mini
	noir - black - schwarz		118642C	1 1 50
	chocolat - chocolate - schokobraun	118623C	118643C	1 1 50
	taupe - taupe	118624C	118644C	1 1 50
	beige - beige	118625C	118645C	1 1 50
	anis - anise - anis	118626C	118646C	1 1 50
	turquoise - turquoise - türkis	118627C	118647C	1 1 50
	saphir - sapphire - saphirblau	118628C	118648C	1 1 50
	iris - iris	118629C	118649C	1 1 50
	violet - purple - violett	118630C	118650C	1 1 50
	lilas - lilac - Lilie	118631C	118651C	1 1 50
	framboise - raspberry - Himbeere	118632C	118652C	1 1 50
	coquelicot - poppy - Mohn	118633C	118653C	1 1 50
	tangerine - tangerin	118634C	118654C	1 1 50
	orange - orange	118635C	118655C	1 1 50
	jonquille - daffodil - Narzisse	118636C	118656C	1 1 50



15
couleurs
colors
Farben

Les Webbies prennent des couleurs ! Quelque part entre l'Orange et le Black, il y a le vôtre.

The Webbies are now in colors! Somewhere between Orange & Black, there is one just for you.

Die Webbies nehmen Farbe an! Ihrer wartet auf Sie, irgendwo zwischen Orange und Black.

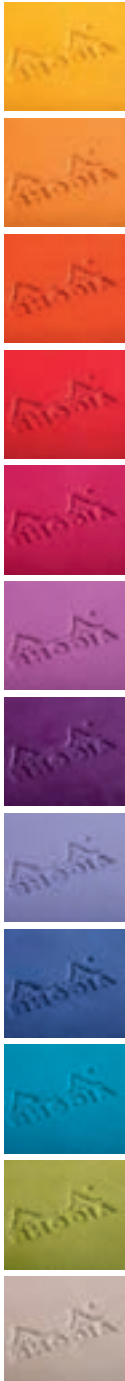

pages de garde orange
orange front and back pages
orangefarbenes Deckblatt



papier ivoire 90 g
90 g ivory paper
90 g elfenbeinfarbenes Papier



pochette à soufflets
expanding pocket
Falttasche

Papier vélin velouté ivoire ou blanc 90 g - Couverture simili cuir 90 g ivory or white brushed vellum paper - Leatherette cover
90 g Velinpapier elfenbein oder weiß - Deckel aus italienischem Kunstleder

RHODIARAMA

Photos non contractuelles - Photos are not contractually binding - Bild vertraglich nicht bindend

Webnotepad

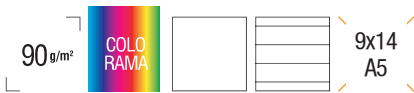

• Couverture rembourrée rigide en simili cuir italien, logo embossé, fermeture élastique orange, rainure pour élastique, 192 pages microperforées, papier vélin velouté ivoire 90 g, pochette à soufflet.

• *Italian leatherette hard cover, embossed logo, orange elastic closure, groove for elastic, 96 microperforated sheets, 90 g ivory brushed vellum paper, expanding inner pocket.*

• Fester Umschlag aus italienischem Kunstleder, geprägtes Logo, orangefarbener Gummizugverschluss, Rille für Gummizug, 96 mikroperforierte Blätter, samtweiches elfenbeinfarbenes Velinpapier 90 g, Falttasche.

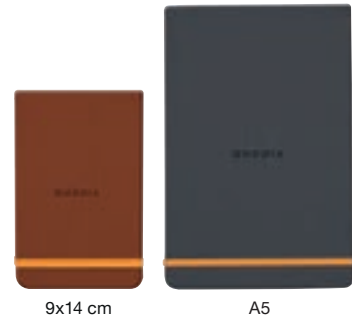

	papier ivoire ivory paper elfenbeinfarbenes Papier	9x 14 L	A5 - 14,8 x 21 L	MINI	
	or - gold - gold	194340C	194370C	1	1
	cuivre - copper - Kupfer	194341C	194371C	1	1
	bronze- bronze - bronze	194342C	194372C	1	1
	titane - titanium - Titan	194343C	194373C	1	1
	argent - silver - silber	194344C	194374C	1	1
	blanc - white - weiß	194345C	194375C	1	1
	noir - black - schwarz	118309C	118349C	1	1
	chocolat - chocolate - schokobraun	194346C	194376C	1	1
	taupe - taupe	194347C	194377C	1	1
	beige - beige	194348C	194378C	1	1
	lie de vin - burgundy - burgund	194349C	194380C	1	1
	nacarat - orangerot	194350C	194381C	1	1
	bois de rose - rosewood - Rosenholz	194351C	194382C	1	1
	touche de rose - rose smoke - Rosendunst	194352C	194383C	1	1
	anis - anise - anis	194353C	194384C	1	1
	sauge - sage - Salbei	194354C	194385C	1	1
	céladon - celadon - celadon	194355C	194386C	1	1
	paon - peacock - Pfau	194356C	194387C	1	1
	eau - aqua - aqua	194357C	194388C	1	1
	turquoise - turquoise - türkis	194358C	194389C	1	1
	bleu nuit - midnight - mitternachtsblau	194359C	194390C	1	1
	saphir - sapphire - saphirblau	194360C	194391C	1	1
	iris - iris	194361C	194392C	1	1
	violet - purple - violett	194362C	194393C	1	1
	lilas - lilac - Lilie	194363C	194394C	1	1
	fuchsia - Fuchsia	194364C	194395C	1	1
	framboise - raspberry - Himbeere	194365C	194397C	1	1
	coquelicot - poppy - Mohn	194366C	194398C	1	1
	corail - coral - Koralle	194367C	194399C	1	1
	tangerine - tangerin	194368C	194400C	1	1
	orange - orange	118308C	118348C	1	1
	jonquille - daffodil - Narzisse	194369C	194401C	1	1

Présentoir/display 32 x A5 - - 194384PC 32



Filmé individuellement - Individually shrink-wrapped - Einzeln in Folie eingeschweißt



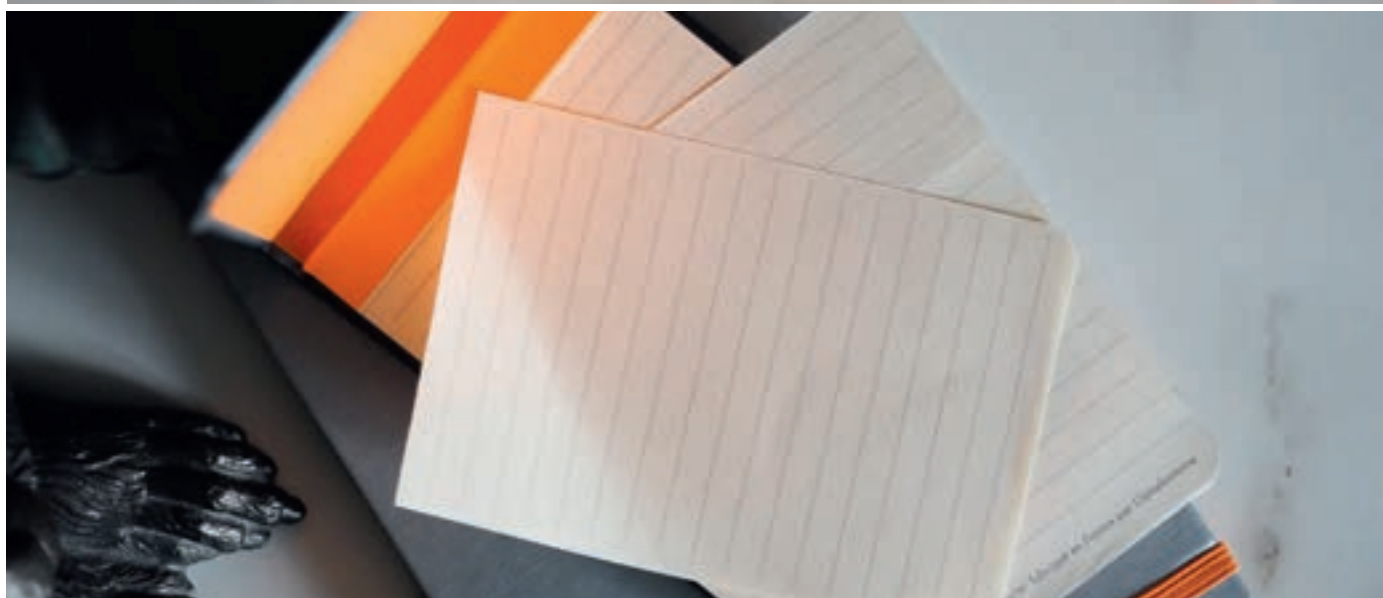

Papier vélin velouté ivoire ou blanc 90 g - Couverture simili cuir 90 g ivory or white brushed vellum paper - Leatherette cover
90 g Velinpapier elfenbein oder weiß - Deckel aus italienischem Kunstleder

Porte-stylo autoadhésif

Self-adhesive pen loop

Selbstklebender Stifthalter



- Simili cuir Italien, logo Rhodia embossé, large passant élastique orange, dos autoadhésif
- Italian leatherette, embossed Rhodia logo, large orange elastic loop, self-adhesive back
- Italienisches Kunstleder, geprägtes Rhodia-Logo, breite orange-farbene Gummizugschleufe, selbstklebende Rückseite

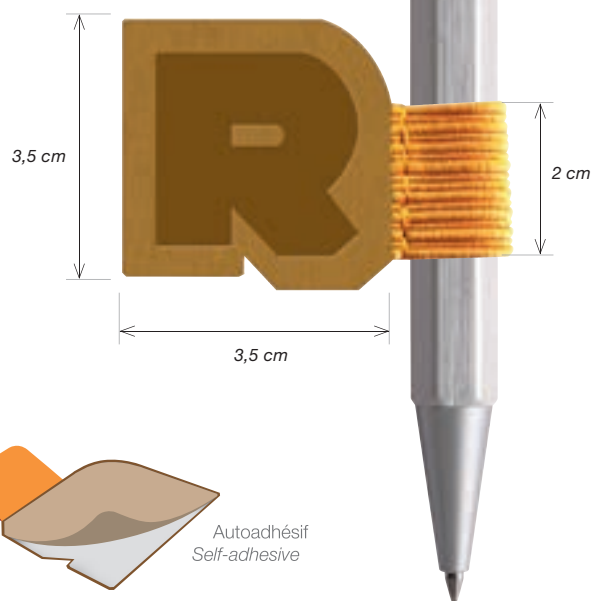

3 x 4 x 0,3		MINI		
or - gold - gold	194182C	1	1	
cuivre - copper - Kupfer	194183C	1	1	
bronze - bronze - bronze	194184C	1	1	
titane - titanium - Titan	194185C	1	1	
argent - silver - silber	194186C	1	1	
blanc - white - weiß	194187C	1	1	
noir - black - schwarz	194188C	1	1	
chocolat - chocolate - schokobraun	194189C	1	1	
taupe - taupe	194190C	1	1	
beige - beige	194191C	1	1	
lie de vin - burgundy - Burgund	194192C	1	1	
nacarat - orangerot	194193C	1	1	
bois de rose - rosewood - Rosenholz	194194C	1	1	
touche de rose - rose smoke - Rosendunst	194195C	1	1	
anis - anise - anis	194197C	1	1	
sauge - sage - Salbei	194198C	1	1	
céladon - celadon - celadon	194199C	1	1	
paon - peacock - Pfau	194200C	1	1	
eau - aqua - aqua	194201C	1	1	
turquoise - turquoise - türkis	194202C	1	1	
bleu nuit - midnight - mitternachtsblau	194203C	1	1	
saphir - sapphire - saphirblau	194204C	1	1	
iris - iris	194205C	1	1	
violet - purple - violett	194207C	1	1	
lilas - lilac - Lilie	194208C	1	1	
fuchsia - Fuchsia	194209C	1	1	
framboise - raspberry - Himbeere	194210C	1	1	
coquelicot - poppy - Mohn	194211C	1	1	
corail - coral - Koralle	194212C	1	1	
tangerine - tangerin	194213C	1	1	
orange - orange	194214C	1	1	
jonquille - daffodil - Narzisse	194215C	1	1	

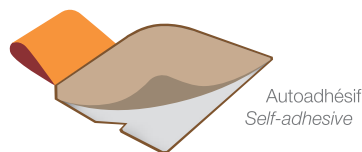

Le porte-stylo autoadhésif permet d'avoir un instrument d'écriture toujours à portée de main. A fixer tout simplement à l'intérieur de la couverture d'un bloc-notes, d'un carnet ou d'un agenda, mais aussi à l'arrière d'un ordinateur portable ou d'une tablette. Il s'adapte à tout type d'outils d'écriture grâce à son large passant élastique orange : stylos à bille, stylos-plumes, crayons à papier ou de couleurs, et autres feutres ou même stylets pour écrans tactiles. Disponible en 32 variantes, il s'accorde tout particulièrement avec tous les carnets Rhodiarama, mais permet aussi bien de personnaliser et égayer les supports les plus classiques.

The self-adhesive pen loop allows you to have a writing instrument always at hand. Simply attach it to the inside cover of a notebook or diary, but also to the back of a laptop or tablet. It fits all types of writing tools thanks to its large orange elastic loop: ballpoint pens, fountain pens, pencils, coloured pencils, felt-tip pens and even touch screen pens. Available in 32 variations, it matches particularly with all Rhodiarama notebooks, but can also be used to personalise and brighten up the most classic of books and pads.

Mit dem selbstklebenden Stifthalter haben Sie Ihr Schreibgerät immer griffbereit. Er wird einfach auf der Innenseite des Einbands eines Notizblocks, Notizbuchs oder Terminkalenders, aber auch auf der Rückseite eines Laptops oder Tablet-PCs befestigt. Dank seiner breiten, orangefarbenen Gummischlaufe passt er sich allen Arten von Schreibgeräten an: Kugelschreiber, Füllfederhalter, Bleistifte oder Buntstifte und andere Filzstifte oder sogar Stifte für Touchscreens. Er ist in 32 Varianten erhältlich und passt besonders gut zu allen Rhodiarama-Notizbüchern, aber auch klassische Schreibgeräte lassen sich damit individuell gestalten und aufpeppen.



Conférencier

Zippered portfolio

Portfolio

- Extérieur et intérieur en simili cuir italien, logo embossé, coutures véritables, fermeture éclair discrète assortie, doublure intérieure en popeline orange, compartiment principal à soufflets, deux poches plates zippées, porte-cartes, porte-crayon
- Italian leatherette outside and inside, embossed logo, genuine stitching, discreet matching zipper, orange poplin inner lining, gusseted main compartment, two flat zippered pockets, cardholder, pencil holder
- Außen und innen italienisches Kunstleder, geprägtes Logo, echte Nähte, passender dezenter Reißverschluss, orangefarbenes Popeline-Innenfutter, Hauptfach mit Falttaschen, zwei flache Taschen mit Reißverschluss, Kartenfach, Stifthalter



petit modèle - small



grand modèle - large

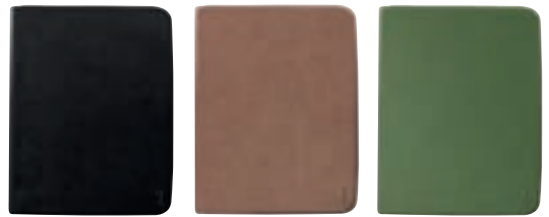

Noir

Taupe

Sauge

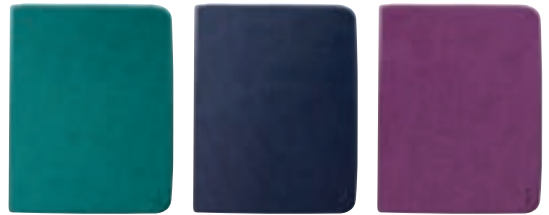

Paon

Bleu nuit

Violet



Coquelicot

Lie de vin

Bois de rose

		petit modèle small - klein	grand modèle large - groß	MINI		
		19,5 x 25,5	25,5 x 34			
	noir - black - schwarz	168100C	20	168116C	10	1
	taupe - taupe	168101C	20	168117C	10	1
	sauge - sage - Salbei	168102C	20	168118C	10	1
	paon - peacock - Pfau	168103C	20	168119C	10	1
	bleu nuit - midnight - mitternachtsblau	168104C	20	168120C	10	1
	violet - purple - violett	168105C	20	168121C	10	1
	coquelicot - poppy - Mohn	168106C	20	168122C	10	1
	lie de vin - burgundy - Burgund	168107C	20	168123C	10	1
	bois de rose - rosewood - Rosenholz	168108C	20	168124C	10	1

Livré dans un coffret en kraft - Delivered in a kraft box - Geliefert in einer Kraftkartonbox





Le compartiment principal à soufflets peut contenir une tablette numérique - Livré sans bloc ou carnet
Gusseted main compartment can hold a digital tablet - Delivered without notebook or pad
Das Hauptfach mit Falttaschen bietet Platz für einen Tablet-PC - Ohne Block oder Notizbuch geliefert

Livret porte-bloc ou carnet

Small portfolio for notepad or book

Block- oder Notizbuchhalter

- Extérieur et intérieur en simili cuir italien, logo embossé, coutures véritables, doublure intérieure en popeline orange, poche plate, porte-crayon
- Italian leatherette outside and inside, embossed logo, genuine stitching, orange poplin inner lining, flat pocket, pencil holder
- Außen- und Innenfutter aus italienischem Kunstleder, geprägtes Logo, echte Nähte, Innenfutter aus orangefarbenem Popelin, flache Tasche, Bleistifthalter

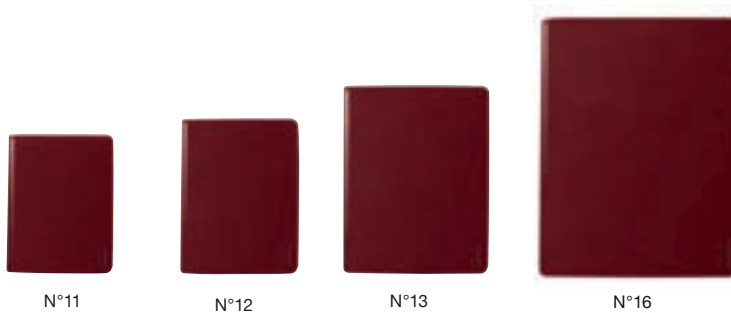

Noir



Taupe

Sauge



Paon

Bleu nuit

		N°11 9,5 x 12,5		N°12 10,5 x 14		N°13 13 x 17		N°16 17,5 x 23,5		MINI	
	noir - black - schwarz	211001C	35	212001C	30	213001C	24	216001C	18	1	1
	taupe - taupe	211002C	35	212002C	30	213002C	24	216002C	18	1	1
	sauge - sage - Salbei	211003C	35	212003C	30	213003C	24	216003C	18	1	1
	paon - peacock - Pfau	211004C	35	212004C	30	213004C	24	216004C	18	1	1
	bleu nuit - midnight - mitternachtsblau	211005C	35	212005C	30	213005C	24	216005C	18	1	1
	violet - purple - violett	211006C	35	212006C	30	213006C	24	216006C	18	1	1
	coquelicot - poppy - Mohn	211007C	35	212007C	30	213007C	24	216007C	18	1	1
	lie de vin - burgundy - Burgund	211008C	35	212008C	30	213008C	24	216008C	18	1	1
	bois de rose - rosewood - Rosenholz	211009C	35	212009C	30	213009C	24	216009C	18	1	1



Violet

Coquelicot



Liev de vin Bois de rose

Livré dans un coffret en kraft - Delivered in a kraft box - Geliefert in einer Kraftkartonbox



Livré sans bloc, carnet, stylo ou accessoires.

Delivered without notepad/book, pen or accessories.



Utilisable avec un bloc ou un carnet - Livré sans bloc, carnet, stylo ou accessoires.
 Can be used with a notepad or a notebook - Delivered without notebook, pad, pen or accessories.
 Verwendbar mit einem Block oder einem Notizbuch - Ohne Block, Notizbuch, Stift oder Zubehör geliefert.

Porte-bloc + bloc

Notepad cover + notepad

Klemmbrett + Block

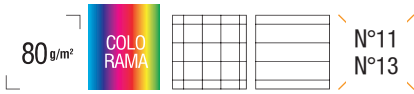

- Extérieur en simili cuir italien coloris assortis, intérieur en simili cuir italien orange, logo embossé, porte-crayon, porte-carte, avec bloc agrafé Orange 5/5 ou ligné
- Assorted colors Italian leatherette outside, orange Italian leatherette inside, embossed logo, pen loop, name-card pocket, 5/5 squared or lined Orange head stapled pad included
- Außen aus farblich passendem italienischem Kunstleder, innen aus orange-farbenem italienischem Kunstleder, geprägtes Logo, Bleistifthalter, Kartenhalter, mit Orange-Heftblock kariert 5/5 oder liniert



N°13

N°12

N°11

couleur argent effet métal brossé
silver color brushed metal effect
silberfarbener gebürsteter Metalleffekt

		8,4 x 11,5 + bloc N°11		9,5 x 13 + bloc N°12		11,5 x 15,8 + bloc N°13 MINI				
		5/5	L	5/5	L	5/5	L			
	argent - silver - silber	118101C	118201C	128101C	128201C	138101C	138201C	1	1	20
	noir - black - schwarz	118119C	218119C	118129C	218129C	118139C	218139C	1	1	20
	chocolat - chocolate - schokobraun	118103C	118203C	128103C	128203C	138103C	138203C	1	1	20
	taupe - taupe	118104C	118204C	128104C	128204C	138104C	138204C	1	1	20
	beige - beige	118105C	118205C	128105C	128205C	138105C	138205C	1	1	20
	anis - anise - anis	118106C	118206C	128106C	128206C	138106C	138206C	1	1	20
	turquoise - turquoise - türkis	118107C	118207C	128107C	128207C	138107C	138207C	1	1	20
	saphir - sapphire - saphirblau	118108C	118208C	128108C	128208C	138108C	138208C	1	1	20
	iris - iris	118109C	118209C	128109C	128209C	138109C	138209C	1	1	20
	violet - purple - violett	118110C	118210C	128110C	128210C	138110C	138210C	1	1	20
	lilas - lilac - Lilie	118111C	118211C	128111C	128211C	138111C	138211C	1	1	20
	framboise - raspberry - Himbeere	118112C	118212C	128112C	128212C	138112C	138212C	1	1	20
	coquelicot - poppy - Mohn	118113C	118213C	128113C	128213C	138113C	138213C	1	1	20
	tangerine - tangerin	118114C	118214C	128114C	128214C	138114C	138214C	1	1	20
	orange - orange	118118C	218118C	118128C	218128C	118138C	218138C	1	1	20
	jonquille - daffodil - Narzisse	118116C	118216C	128116C	128216C	138116C	138216C	1	1	20



Filmé individuellement - Individually shrink-wrapped - Einzel in Folie eingeschweißt



Papier vélin surfon 80 g - Couverture simili cuir | 80 g superfine vellum paper - Leatherette cover | 90 g Velinpapier - Deckel aus italienischem Kunstleder

16 Jamais sans mon porte-bloc! L'accessoire tendance indispensable pour habiller votre bloc Rhodia. À adopter d'urgence!
 couleurs Never without my Rhodiarama cover! Very important trendy accessory for your Rhodia notepad. A must-have!
 colors Nie ohne mein Klemmbrett! Das unverzichtbare Trend-Accessoire, um Ihren Rhodia-Block zu verschönern. Ein
 Farben absolutes Muss!



Papier vélin surfín 80 g - Couverture simili cuir | 80 g superfine vellum paper - Leatherette cover | 90 g Velinpapier - Deckel aus italienischem Kunstleder

RHODIARAMA

Photos non contractuelles - Photos are not contractually binding - Bild vertraglich nicht bindend

Porte-bloc + bloc

Notepad cover + notepad

Klemmbrett + Block



- Extérieur simili cuir italien orange ou noir, intérieur simili cuir italien noir, logo embossé, porte-crayon et porte-carte, contient un bloc agrafé 5/5 ou ligné
- Orange or black Italian leatherette outside, black Italian leatherette inside, embossed logo, pen loop and card holder, 5/5 sq. or lined head stapled pad included
- Außenseite aus italienischem Kunstleder in Orange oder Schwarz, Innenseite aus italienischem Kunstleder in Schwarz, geprägtes Logo, Bleistifthalter und Kartenhalter, enthält einen 5/5 karierten oder linierten Heftblock

	8,4 x 22 + bloc N°8	5/5	L	mini
	orange	118098C	218098C	1
	noir - black - schwarz	118099C	218099C	1
	16 x 16 + Le Carré N°148	5/5	L	mini
	orange	118148C		1
	noir - black - schwarz	118149C		1
	15,5 x 22,3 + bloc N°16	5/5	L	mini
	orange	118168C	218168C	1
	noir - black - schwarz	118169C	218169C	1
	22 x 22 + Le Carré N°210	5/5	L	mini
	orange	118318C		1
	noir - black - schwarz	118319C		1
	22 x 30,8 + bloc N°18	5/5	L	mini
	orange	118188C	218188C	1
	noir - black - schwarz	118189C	218189C	1
	22 x 32,5 + bloc N°19	5/5	L	mini
	orange	118198C	218198C	1
	noir - black - schwarz	118199C	218199C	1

Emballé individuellement - Individually shrink-wrapped - Einzeln in Folie eingeschweißt



N°8



N°148



N°16



N°210



N°18



N°19



porte-carte
card holder
Kartenhalter



porte-crayon
pen loop
Stiftehalter



logo Rhodia embossé
Rhodia logo embossed
Geprägtes Rhodia-Logo

Papier vélin surfín 80 g - Couverture simili cuir | 80 g superfine vellum paper - Leatherette cover | 90 g Velinpapier - Deckel aus italienischem Kunstleder



Revêtu d'une protection sobre et élégante façon cuir, votre bloc Rhodia vous accompagne partout!

An elegant and hard-wearing leatherette protection for your Rhodia notepad.

Mit einem schlichten und eleganten Überzug in Lederoptik versehen, begleitet Sie Ihr Rhodia-Block überall hin!



Photos non contractuelles - Photos are not contractually binding - Bild vertraglich nicht bindend

Papier vélin surfon 80 g - Couverture simili cuir | 80 g superfine vellum paper - Leatherette cover | 90 g Velinpapier - Deckel aus italienischem Kunstleder

RHODIARAMA

Trousse plumier

Zippered hard case pencil box

Federtasche

- Extérieur en simili cuir italien, logo embossé, coutures véritables, doublure intérieure en popeline orange, longue fermeture éclair (utilisable en anse quand fixée par bouton pression), ouverture à plat pour utilisation en tant que plumier
- Italian leatherette outside, embossed logo, genuine stitching, orange poplin inner lining, long zipper (can be used as a handle when fastened with the snap), flat opening for use as a pencil case.
- Außenseite aus italienischem Kunstleder, geprägtes Logo, echte Nähte, Innenfutter aus orangefarbenem Popelin, langer Reißverschluss (kann als Henkel verwendet werden, wenn mit Druckknopf befestigt), flache Öffnung zur Verwendung als Federtasche

23 x 5 x 5 cm		MINI		
	or - gold - gold	319038C	1	24
	cuivre - copper - Kupfer	319039C	1	24
	bronze- bronze - bronze	319040C	1	24
	titane - titanium - Titan	319041C	1	24
	argent - silver - silber	319011C	1	24
	blanc - white - weiß	319042C	1	24
	noir - black - schwarz	319012C	1	24
	chocolat - chocolate - schokobraun	319013C	1	24
	taupe - taupe	319014C	1	24
	beige - beige	319015C	1	24
	lie de vin - burgundy - Burgund	319027C	1	24
	nacarat - orangerot	319028C	1	24
	bois de rose - rosewood - Rosenholz	319029C	1	24
	touche de rose - rose smoke - Rosendunst	319030C	1	24
	anis - anise - anis	319016C	1	24
	sauge - sage - Salbei	319031C	1	24
	céladon - celadon - celadon	319032C	1	24
	paon - peacock - Pfau	319033C	1	24
	eau - aqua - aqua	319034C	1	24
	turquoise - turquoise - türkis	319017C	1	24
	bleu nuit - midnight - mitternachtsblau	319035C	1	24
	saphir - sapphire - saphirblau	319018C	1	24
	iris - iris	319019C	1	24
	violet - purple - violett	319020C	1	24
	lilas - lilac - Lilie	319021C	1	24
	fuchsia - Fuchsia	319036C	1	24
	framboise - raspberry - Himbeere	319022C	1	24
	coquelicot - poppy - Mohn	319023C	1	24
	corail - coral - Koralle	319037C	1	24
	tangerine - tangerin	319024C	1	24
	orange - orange	319025C	1	24
	jonquille - daffodil - Narzisse	319026C	1	24
Présentoirs/displays x 32		319038PC	32	



Filmé individuellement - Individually shrink-wrapped - Einzeln in Folie eingeschweißt

RHODIARAMA

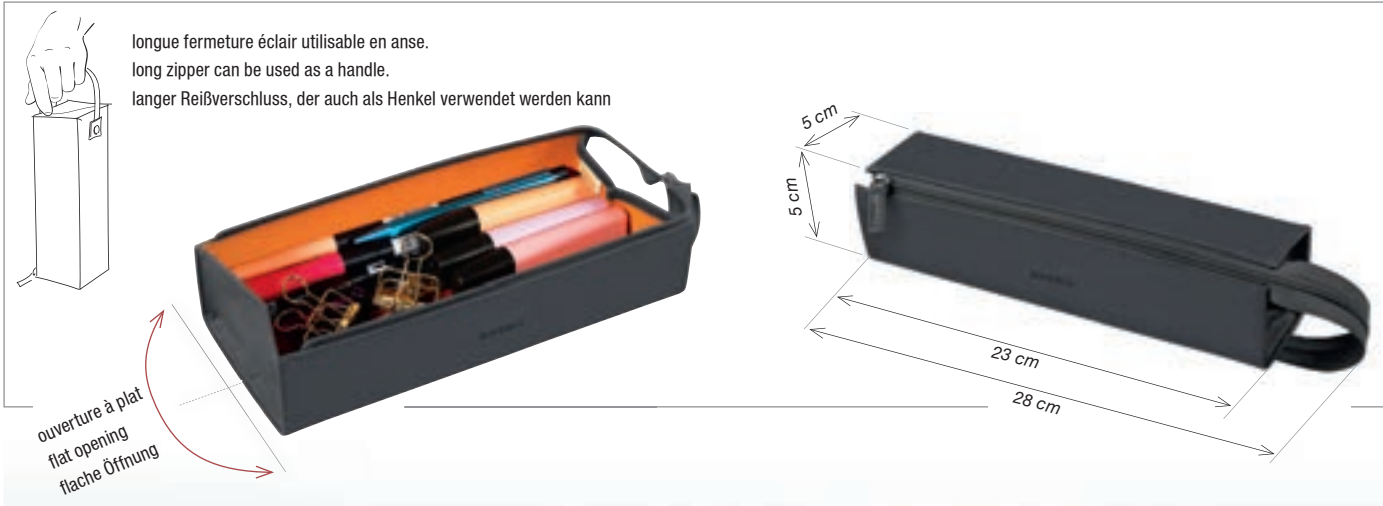

Photos non contractuelles - Photos are not contractually binding - Bild vertraglich nicht bindend

Trousse ronde

Round pencil case

Rundes Federmäppchen

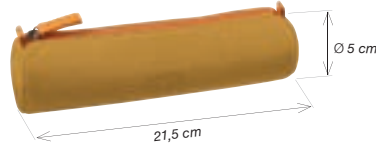

- Extérieur en simili cuir italien, logo embossé, coutures véritables orange, fermeture éclair orange, tirette en simili cuir orange, intérieur jersey ivoire
- Italian leatherette outside, embossed logo, orange zipper, orange leatherette puller, ivory jersey inner lining
- Außenseite aus italienischem Kunstleder, geprägtes Logo, echte orangefarbene Nähte, orangefarbener Reißverschluss, orangefarbene Reißverschlusslasche aus Kunstleder, Innenseite aus elfenbeinfarbenem Jersey

	21,5 x Ø 5		MINI		
	or - gold - gold	319043C	1	1	24
	cuivre - copper - Kupfer	319044C	1	1	24
	bronze- bronze - bronze	319045C	1	1	24
	titane - titanium - Titan	319046C	1	1	24
	argent - silver - silber	318891C	1	1	24
	blanc - white - weiß	319047C	1	1	24
	noir - black - schwarz	318892C	1	1	24
	chocolat - chocolate - schokobraun	318893C	1	1	24
	taupe - taupe	318894C	1	1	24
	beige - beige	318895C	1	1	24
	lie de vin - burgundy - Burgund	319000C	1	1	24
	nacarat - orangerot	319001C	1	1	24
	bois de rose - rosewood - Rosenholz	319002C	1	1	24
	touche de rose - rose smoke - Rosendunst	319003C	1	1	24
	anis - anise - anis	318896C	1	1	24
	saugé - sage - Salbei	319004C	1	1	24
	céladon - celadon - celadon	319005C	1	1	24
	paon - peacock - Pfau	319006C	1	1	24
	eau - aqua - aqua	319007C	1	1	24
	turquoise - turquoise - türkis	318897C	1	1	24
	bleu nuit - midnight - mitternachtsblau	319008C	1	1	24
	saphir - sapphire - saphirblau	318898C	1	1	24
	iris - iris	318899C	1	1	24
	violet - purple - violett	318990C	1	1	24
	lilas - lilac - Lilie	318991C	1	1	24
	fuchsia - Fuchsia	319009C	1	1	24
	framboise - raspberry - Himbeere	318992C	1	1	24
	coquelicot - poppy - Mohn	318993C	1	1	24
	corail - coral - Koralle	319010C	1	1	24
	tangerine - tangerin	318994C	1	1	24
	orange - orange	318890C	1	1	24
	jonquille - daffodil - Narzisse	318996C	1	1	24
	Présentoirs/displays x 32	318891PC			32



Filmé individuellement - Individually shrink-wrapped - Einzeln in Folie eingeschweißt



Photos non contractuelles - Photos are not contractually binding - Bild vertraglich nicht bindend

RHODIARAMA

Pochette Zippée

Zipped pouch

Reißverschlusstäschchen



- pochette zippée en simili cuir italien, logo Rhodia embossé, tirette en simili cuir cousu
- Italian leatherette zipped pouch, embossed Rhodia logo, foam padding, leatherette puller
- Italienisches Kunstleder Reißverschlusstäschchen, geprägtes Logo, Schaumstoff-Polsterung



S 11x17 cm



M 16x22 cm



L 21x28 cm

3 formats disponibles
3 sizes available
3 Formate erhältlich

	S 11 x 17	M 16 x 22	L 21 x 28	MINI	📦
or - gold - gold	116517C NEW	116617C NEW	116717C NEW	1	1
cuirre - copper - Kupfer	116518C NEW	116618C NEW	116718C NEW	1	1
bronze- bronze - bronze	116519C NEW	116619C NEW	116719C NEW	1	1
titane - titanium - Titan	116520C NEW	116620C NEW	116720C NEW	1	1
argent - silver - silber	116521C NEW	116621C NEW	116721C NEW	1	1
blanc - white - weiß	116522C NEW	116622C NEW	116722C NEW	1	1
noir - black - schwarz	116523C NEW	116623C NEW	116723C NEW	1	1
chocolat - chocolate - Schokobraun	116524C NEW	116624C NEW	116724C NEW	1	1
taupe - taupe	116525C NEW	116625C NEW	116725C NEW	1	1
beige - beige	116526C NEW	116626C NEW	116726C NEW	1	1
lie de vin - burgundy - Burgund	116527C NEW	116627C NEW	116727C NEW	1	1
nacarat - orangerot	116528C NEW	116628C NEW	116728C NEW	1	1
bois de rose - rosewood - Rosenholz	116529C NEW	116629C NEW	116729C NEW	1	1
touche de rose - rose smoke - Rosendunst	116530C NEW	116630C NEW	116730C NEW	1	1
anis - anise green - anisgrün	116531C NEW	116631C NEW	116731C NEW	1	1
sauge - sage - Salbei	116532C NEW	116632C NEW	116732C NEW	1	1
céladon - celadon - celadon	116533C NEW	116633C NEW	116733C NEW	1	1
paon - peacock - Pfau	116534C NEW	116634C NEW	116734C NEW	1	1
eau - aqua - aqua	116535C NEW	116635C NEW	116735C NEW	1	1
turquoise - turquoise blue - türkis	116536C NEW	116636C NEW	116736C NEW	1	1
bleu nuit - midnight - mittnachtsblau	116537C NEW	116637C NEW	116737C NEW	1	1
saphir - sapphire blue - saphirblau	116538C NEW	116638C NEW	116738C NEW	1	1
iris - iris	116539C NEW	116639C NEW	116739C NEW	1	1
violet - purple - violett	116540C NEW	116640C NEW	116740C NEW	1	1
lilas - lilac - Lilie	116541C NEW	116641C NEW	116741C NEW	1	1
fuchsia - Fuchsie	116542C NEW	116642C NEW	116742C NEW	1	1
framboise - raspberry - himbeerrot	116543C NEW	116643C NEW	116743C NEW	1	1
coquelicot - poppy - Mohn	116544C NEW	116644C NEW	116744C NEW	1	1
corail - coral - Koralle	116545C NEW	116645C NEW	116745C NEW	1	1
tangerine - tangerin - Mandarine	116546C NEW	116646C NEW	116746C NEW	1	1
orange - orange	116547C NEW	116647C NEW	116747C NEW	1	1
jonquille - daffodil yellow - Narzisse	116548C NEW	116648C NEW	116748C NEW	1	1



Filmé individuellement - Individually shrink-wrapped - Einzel in Folie eingeschweißt



Rangez votre tablette, vos écouteurs, les indispensables chargeurs et conservez vos objets précieux en sécurité dans une pochette zippée Rhodiarama !

Keep your tablet, headphones, indispensable chargers and other precious belongings safe in a Rhodiarama zipped pouch!

Bewahren Sie Ihr Tablet, Ihre Kopfhörer, Ihre Ladegeräte und andere wertvolle Gegenstände sicher in einer Rhodiarama-Reißverschluss tasche auf!



RHODIARAMA

Photos non contractuelles - Photos are not contractually binding - Bild vertraglich nicht bindend

- Célestin*
- Faon*
- Eau*
- Turquoise*
- Bleu nuit*
- Saphir*
- Tris*
- Viollet*
- Lilas*
- Fuchsia*
- Framboise*
- Cognac/rot*
- Corail*
- Tangerine*
- Orange*
- Forgiville*



Trousse cuir ePURE

Rhodia leather pencil case

Lederfedermäppchen ePURE

NOIR
BLACK
SCHWARZ

- Trousse plate en cuir souple noir, tirette métallique, logo Rhodia embossé
- Black genuine leather pencil case, metallic puller, embossed Rhodia logo
- *Flaches Federmäppchen aus weichem, schwarzem Leder mit Metallreißverschluss, geprägtes Rhodia-Logo*

	22 x 8,5		
	noir - black - schwarz	118449C	4





Photos non contractuelles - Photos are not contractually binding - Bild vertraglich nicht bindend

RHODIARAMA

Affiches, nuancier et PLV

Posters, swatch book and POS advertising

Poster, Farbpalette und POS

	français French Französisch	anglais English Englisch	
La vie est plus belle - Life is beautiful - Das Leben ist wunderbar!	250047C	250048C	1
Goûts et couleurs - Feed your creativity	250051C	250052C	1



FR - 250047C
GB - 250048C



FR - 250051C
GB - 250052C

A5 - 14,8 x 21	
nuancier triptyque Rhodiarama	999939C 1
Rhodiarama swatch book - Rhodiarama-Musterbuch	

15,5 x 20 x 15,5	
présentoir Rhodiarama + 50 dépliant	116134C 1
display + 50 leaflets - Display + 50 Prospekte	
recharge 50 dépliant Rhodiarama	116135C 50
50 leaflets refill - 50er Nachfüllpack Prospekte	



A5

ne bascule pas, ne s'envole pas
will not fall over or blow away
kippt nicht, hebt nicht ab

ne se déforme pas
sturdy and tear-resistant
verformt sich nicht

recyclable
recyclable
recyclbar

se place et se déplace facilement
easy to install and easy to move
lässt sich leicht platzieren und verschieben

adhère sans colle sur toutes les surfaces lisses
will stick - without glue - on any flat, smooth surface
haftet ohne Klebstoff auf allen glatten Oberflächen

résiste à l'eau et au vent
rain & wind resistant
regen- und windbeständig



999939C

32 couleurs / 32 colors



collection Rhodiarama - 32 couleurs de carnets, cahiers et accessoires



*La vie est plus belle
en Rhodiarama !*



RHODIARAMA

Photos non contractuelles - Photos are not contractually binding - Bild vertraglich nicht bindend



RHODIARAMA

Design unicolore

One-color design
Einfarbiges Design



RHODIARAMA

Photos non contractuelles - Photos are not contractually binding - Bildverfügbarkeit nicht bindend

Support pour téléphone mobile

Mobile phone stand

Handyhalter

- Recto et verso en simili cuir italien, logo Rhodia embossé, deux parties à assembler
- Italian leatherette front and back, embossed Rhodia logo, two parts to be assembled
- Vorder- und Rückseite aus italienischem Kunstleder, geprägtes Rhodia-Logo, zweiteilig zum Zusammenstecken

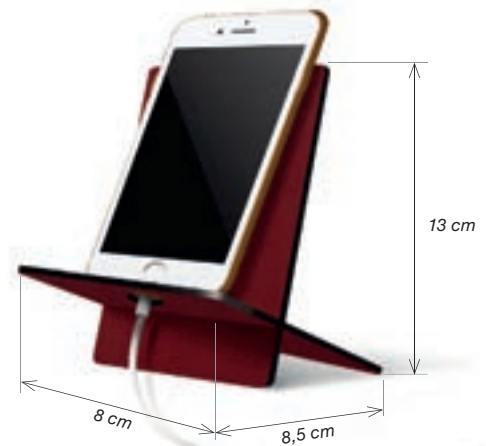

8 x 8,5 x 13		MINI	
	or - gold - gold	194402C	1 1
	cuivre - copper - Kupfer	194403C	1 1
	bronze - bronze - Bronze	194404C	1 1
	titane - titanium - Titan	194405C	1 1
	argent - silver - silber	194407C	1 1
	noir - black - schwarz	194409C	1 1
	chocolat - chocolate - Schokobraun	194410C	1 1
	taupe - taupe	194411C	1 1
	beige - beige	194412C	1 1
	lie de vin - burgundy - Burgund	194413C	1 1
	nacarat - orangerot	194414C	1 1
	bois de rose - rosewood - Rosenholz	194415C	1 1
	touche de rose - rose smoke - Rosendunst	194416C	1 1
	anis - anise green - anisgrün	194417C	1 1
	sauge - sage - Salbei	194418C	1 1
	céladon - celadon - celadon	194419C	1 1
	paon - peacock - Pfau	194420C	1 1
	eau - aqua - aqua	194421C	1 1
	turquoise - turquoise blue - türkis	194422C	1 1
	bleu nuit - midnight - mitternachtsblau	194423C	1 1
	saphir - sapphire blue - saphirblau	194424C	1 1
	iris - iris	194425C	1 1
	violet - purple - violett	194426C	1 1
	lilas - lilac - Lilie	194427C	1 1
	fuchsia - Fuchsie	194428C	1 1
	framboise - raspberry - himbeerrot	194429C	1 1
	coquelicot - poppy - Mohn	194430C	1 1
	corail - coral - Koralle	194431C	1 1
	tangerine - tangerin - Mandarine	194432C	1 1
	orange - orange	194433C	1 1
	jonquille - daffodil yellow - Narzisse	194435C	1 1



Filmé individuellement - Individually shrink-wrapped - Einzel in Folie eingeschweißt

Malin et pratique ! Ne plus garder le téléphone en main pour passer un appel, regarder une vidéo ou participer à une réunion virtuelle. Chic avec son design épuré en simili cuir premium, il est aussi ultra-léger, facile à monter et démonter, et vous suivra partout ! Permet la recharge grâce à l'ouverture pour le passage d'un câble. Les dimensions conviennent à la plupart des téléphones mobiles d'aujourd'hui.

A clever and practical stand that will take your phone out of your hand when you make a call, watch a video or a film or take part in a virtual meeting. Chic with its sleek premium leatherette design, it is also ultra-light, easy to assemble and disassemble, and will follow you everywhere! It allows you to recharge your phone thanks to the opening for a cable. The dimensions fit most of today's cell phones.

*Clever und praktisch! Halten Sie das Telefon nicht mehr in der Hand, um einen Anruf zu tätigen, ein Video anzusehen oder an einem virtuellen Meeting teilzunehmen.
Mit seinem schlichten Design aus Premium-Kunstleder sieht es nicht nur schick aus, sondern ist auch ultraleicht, einfach auf- und abzubauen und wird Sie überall hin begleiten! Ermöglicht das Aufladen dank der Öffnung für die Durchführung eines Kabels. Die Abmessungen eignen sich für die meisten aktuellen Handymodelle.*

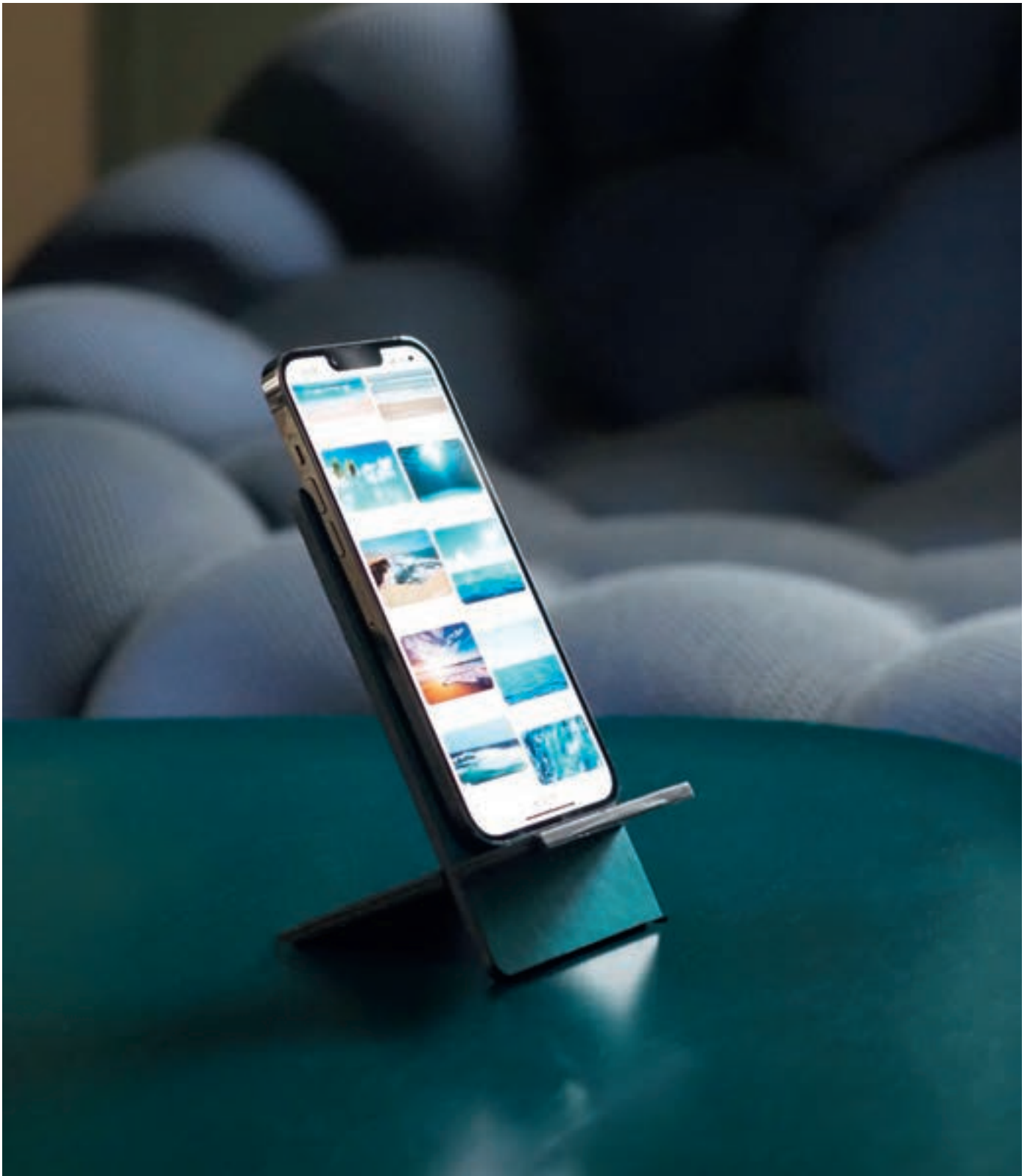

Photos non contractuelles - Photos are not contractually binding - Bild vertraglich nicht bindend

RHODIARAMA

Vide-poche réversible

Reversible tidy

Umkehrbarer Taschenleerer

- Recto/verso en simili cuir italien, logo Rhodia embossé, piqûres sellier orange, 4 aimants
- Italian leatherette front and back, embossed Rhodia logo, orange saddle stitching, 4 magnets
- Vorder- und Rückseite aus italienischem Kunstleder, geprägtes Rhodia-Logo, orangefarbene Sattelstiche, 4 Magnete

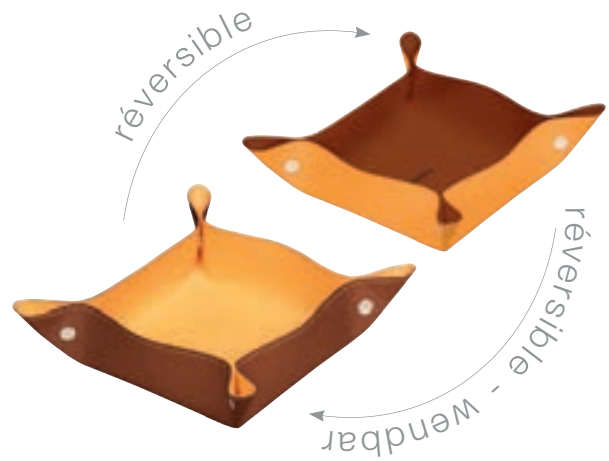

12 x 12 x 4,5		MINI		
	or - gold - gold	194583C	2	2 10
	cuivre - copper - Kupfer	194584C	2	2 10
	bronze - bronze - bronze	194585C	2	2 10
	titane - titanium - Titan	194586C	2	2 10
	argent - silver - silber	318851C	2	2 10
	noir - black - schwarz	118850C	2	2 50
	chocolat - chocolate - Schokobraun	318853C	2	2 10
	taupe - taupe	318854C	2	2 10
	beige - beige	318855C	2	2 10
	lie de vin - burgundy - Burgund	194587C	2	2 10
	nacarat - orangerot	194588C	2	2 10
	bois de rose - rosewood - Rosenholz	194589C	2	2 10
	touche de rose - rose smoke - Rosendunst	194590C	2	2 10
	anis - anise green - anisgrün	318856C	2	2 10
	sauge - sage - Salbei	194591C	2	2 10
	céladon - celadon - celadon	194592C	2	2 10
	paon - peacock - Pfau	194593C	2	2 10
	eau - aqua - aqua	194594C	2	2 10
	turquoise - turquoise blue - türkis	318857C	2	2 10
	bleu nuit - midnight - mitternachtsblau	194595C	2	2 10
	saphir - sapphire blue - saphirblau	318858C	2	2 10
	iris - iris	318859C	2	2 10
	violet - purple - violett	318950C	2	2 10
	lilas - lilac - Lilie	318951C	2	2 10
	fuchsia - Fuchsie	194597C	2	2 10
	framboise - raspberry - himbeerrot	318952C	2	2 10
	coquelicot - poppy - Mohn	318953C	2	2 10
	corail - coral - Koralle	194598C	2	2 10
	tangerine - tangerin - Mandarine	318954C	2	2 10
	jonquille - daffodil yellow - Narzisse	318956C	2	2 10

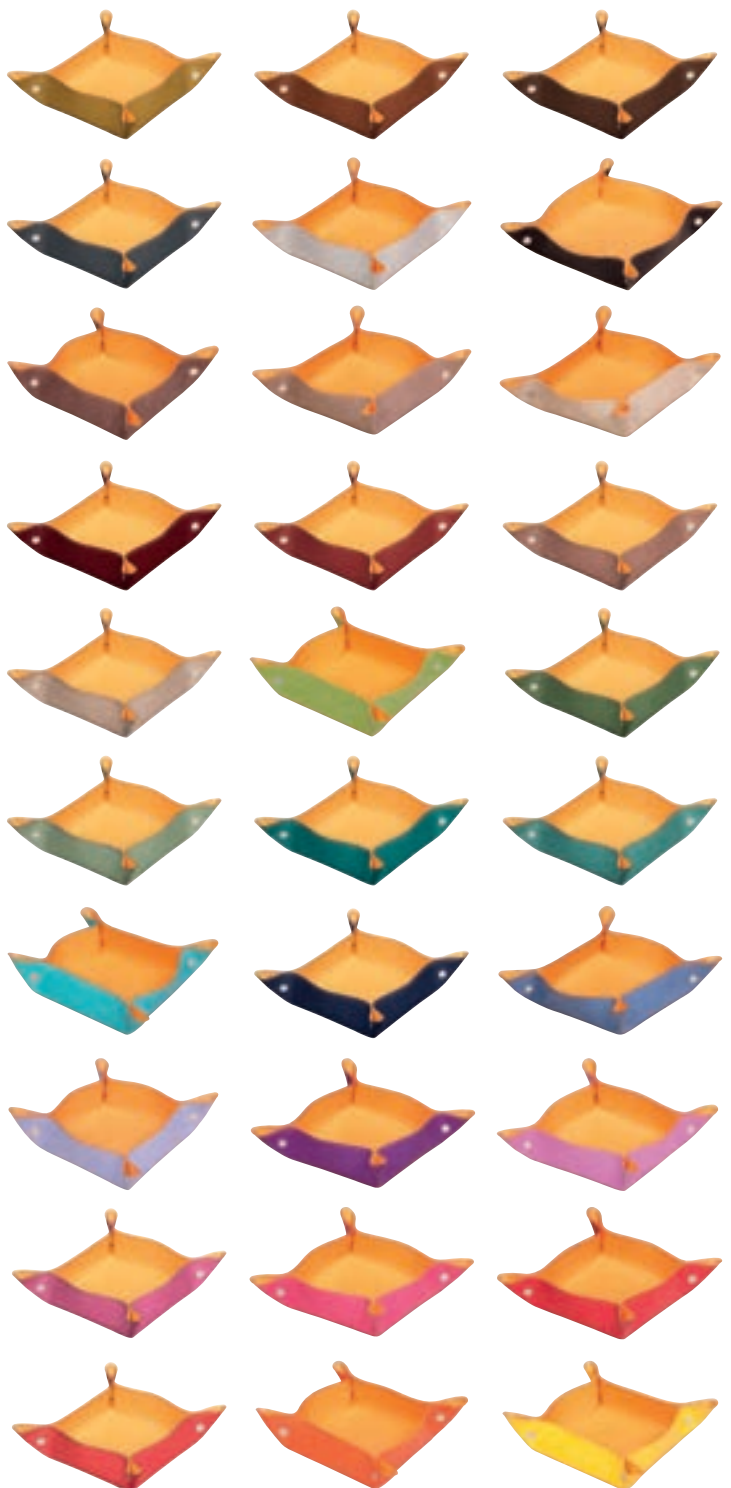

Filmé individuellement - Individually shrink-wrapped - Einzeln in Folie eingeschweißt



aimants
magnets
Magneten



réversible
reversible
wendbar



Plumier

Pencil box

Federtasche

- Extérieur en simili cuir italien, logo Rhodia embossé, piqûres sellier orange
- Italian leatherette, embossed Rhodia logo, orange saddle stitching
- Außenseite aus italienischem Kunstleder, geprägtes Rhodia-Logo, orangefarbene Sattelstiche

	21 x 5,5 x 3		MINI		
	or - gold - gold	194507C	1	1	10
	cuire - copper - Kupfer	194508C	1	1	10
	bronze - bronze - bronze	194509C	1	1	10
	titane - titanium - Titan	194510C	1	1	10
	argent - silver - silber	318871C	1	1	10
	noir - black - schwarz	118876C	1	1	10
	chocolat - chocolate - Schokobraun	318873C	1	1	10
	taupe - taupe	318874C	1	1	10
	beige - beige	318875C	1	1	10
	lie de vin - burgundy - Burgund	194511C	1	1	10
	nacarat - orangerot	194512C	1	1	10
	bois de rose - rosewood - Rosenholz	194513C	1	1	10
	touche de rose - rose smoke - Rosendunst	194514C	1	1	10
	anis - anise green - anisgrün	318876C	1	1	10
	sauge - sage - Salbei	194515C	1	1	10
	céladon - celadon - celadon	194516C	1	1	10
	paon - peacock - Pfau	194517C	1	1	10
	eau - aqua - aqua	194518C	1	1	10
	turquoise - turquoise blue - türkis	318877C	1	1	10
	bleu nuit - midnight - mitternachtsblau	194519C	1	1	10
	saphir - sapphire blue - saphirblau	318878C	1	1	10
	iris - iris	318879C	1	1	10
	violet - purple - violett	319780C	1	1	10
	lilas - lilac - Lilie	319781C	1	1	10
	fuchsia - Fuchsie	194520C	1	1	10
	framboise - raspberry - himbeerrot	319782C	1	1	10
	coquelicot - poppy - Mohn	319783C	1	1	10
	corail - coral - Koralle	194521C	1	1	10
	tangerine - tangerin - Mandarine	319784C	1	1	10
	orange - orange	118870C	1	1	10
	jonquille - daffodil yellow - Narzisse	319786C	1	1	10

Filmé individuellement - Individually shrink-wrapped - Einzeln in Folie eingeschweißt





intérieur orange
orange inside
innen orange



Photos non contractuelles - Photos are not contractually binding - Bild vertraglich nicht bindend

RHODIARAMA

Pot à crayons

Pencil holder

Stiftehalter

- Extérieur en simili cuir italien, logo Rhodia embossé, piqûres sellier orange
- Italian leatherette, embossed Rhodia logo, orange saddle stitching
- Außenseite aus italienischem Kunstleder, geprägtes Rhodia-Logo, orangefarbene Sattelstiche



quatre compartiments
divided into four compartments
in vier Abschnitte unterteilt

	8 x 8 x 11		MINI		
	or - gold - gold	194522C	1	1	12
	cuivre - copper - Kupfer	194523C	1	1	12
	bronze - bronze - bronze	194524C	1	1	12
	titane - titanium - Titan	194525C	1	1	12
	argent - silver - silber	318811C	1	1	12
	noir - black - schwarz	118816C	1	1	12
	chocolat - chocolate - Schokobraun	318813C	1	1	12
	taupe - taupe	318814C	1	1	12
	beige - beige	318815C	1	1	12
	lie de vin - burgundy - Burgund	194526C	1	1	12
	nacarat - orangerot	194527C	1	1	12
	bois de rose - rosewood - Rosenholz	194528C	1	1	12
	touche de rose - rose smoke - Rosendunst	194529C	1	1	12
	anis - anise green - anisgrün	318816C	1	1	12
	sauge - sage - Salbei	194530C	1	1	12
	céladon - celadon - celadon	194531C	1	1	12
	paon - peacock - Pfau	194532C	1	1	12
	eau - aqua - aqua	194533C	1	1	12
	turquoise - turquoise blue - türkis	318817C	1	1	12
	bleu nuit - midnight - mitternachtsblau	194534C	1	1	12
	saphir - sapphire blue - saphirblau	318818C	1	1	12
	iris - iris	318819C	1	1	12
	violet - purple - violett	318910C	1	1	12
	lilas - lilac - Lilie	318911C	1	1	12
	fuchsia - Fuchsie	194535C	1	1	12
	framboise - raspberry - himbeerrot	318912C	1	1	12
	coquelicot - poppy - Mohn	318913C	1	1	12
	corail - coral - Koralle	194537C	1	1	12
	tangerine - tangerin - Mandarine	318914C	1	1	12
	orange - orange	118810C	1	1	12
	jonquille - daffodil yellow - Narzisse	318916C	1	1	12



Filmé individuellement - Individually shrink-wrapped - Einzeln in Folie eingeschweißt



Photos non contractuelles - Photos are not contractually binding - Bild vertraglich nicht bindend

RHODIARAMA

Porte-courrier

Letter holder

Briefhalter

- Extérieur en simili cuir italien, logo Rhodia embossé, piqûres sellier orange
- Italian leatherette, embossed Rhodia logo, orange saddle stitching
- Italienisches Kunstleder, geprägtes Rhodia-Logo, oran5gefärbene Sattelstiche

25 x 10 x 14		MINI		
	or - gold - gold	194599C	1	4
	cuiivre - copper - Kupfer	194600C	1	4
	bronze- bronze - bronze	194601C	1	4
	titane - titanium - Titan	194602C	1	4
	argent - silver - silber	318841C	1	4
	noir - black - schwarz	118846C	1	4
	chocolat - chocolate - Schokobraun	318843C	1	4
	taupe - taupe	318844C	1	4
	beige - beige	318845C	1	4
	lie de vin - burgundy - Burgund	194603C	1	4
	nacarat - orangerot	194604C	1	4
	bois de rose - rosewood - Rosenholz	194605C	1	4
	touche de rose - rose smoke - Rosendunst	194607C	1	4
	anis - anise green - anisgrün	318846C	1	4
	sauge - sage - Salbei	194608C	1	4
	céladon - celadon - celadon	194609C	1	4
	paon - peacock - Pfau	194610C	1	4
	eau - aqua - aqua	194611C	1	4
	turquoise - turquoise blue - türkis	318847C	1	4
	bleu nuit - midnight - mitternachtsblau	194612C	1	4
	saphir - sapphire blue - saphirblau	318848C	1	4
	iris - iris	318849C	1	4
	violet - purple - violett	318940C	1	4
	lilas - lilac - Lilie	318941C	1	4
	fuchsia - Fuchsie	194613C	1	4
	framboise - raspberry - himbeerrot	318942C	1	4
	coquelicot - poppy - Mohn	318943C	1	4
	corail - coral - Koralle	194614C	1	4
	tangerine - tangerin - Mandarine	318944C	1	4
	orange - orange	118840C	1	4
	jonquille - daffodil yellow - Narzisse	318946C	1	4



avec séparateur
with divider
mit Trennwand

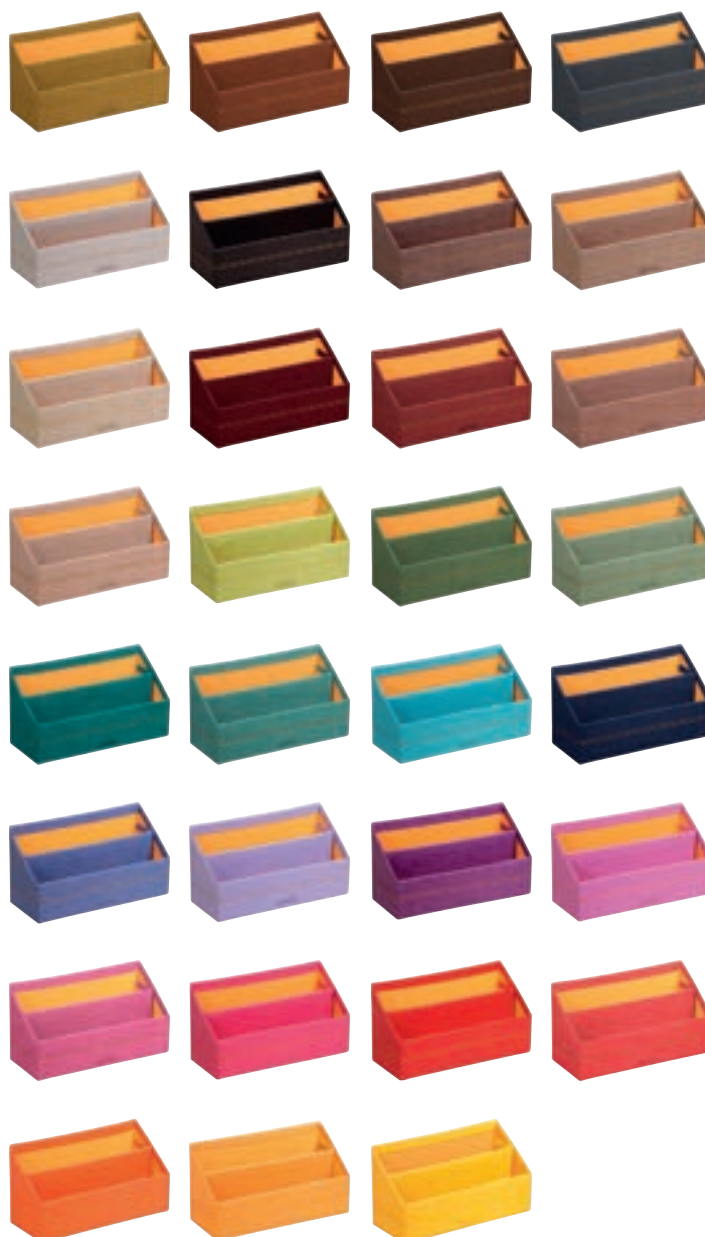

Filmé individuellement - Individually shrink-wrapped - Einzeln in Folie eingeschweißt



Porte-revues

Magazine rack

Stehsammler

- Extérieur en simili cuir italien, logo Rhodia embossé, piqûres sellier orange, porte-étiquette en métal brossé
- Italian leatherette, embossed Rhodia logo, orange saddle stitching, brushed metal label holder
- Außenseite aus italienischem Kunstleder, geprägtes Rhodia-Logo, orangefarbene Sattelstiche, Etikettenhalter aus gebürstetem Metall

10 x 25 x 31		MINI		
	or - gold - gold	194538C	1	1 4
	cuivre - copper - Kupfer	194539C	1	1 4
	bronze- bronze - bronze	194540C	1	1 4
	titane - titanium - Titan	194541C	1	1 4
	argent - silver - silber	318831C	1	1 4
	noir - black - schwarz	118836C	1	1 4
	chocolat - chocolate - Schokobraun	318833C	1	1 4
	taupe - taupe	318834C	1	1 4
	beige - beige	318835C	1	1 4
	lie de vin - burgundy - Burgund	194542C	1	1 4
	nacarat - orangerot	194543C	1	1 4
	bois de rose - rosewood - Rosenholz	194544C	1	1 4
	touche de rose - rose smoke - Rosendunst	194545C	1	1 4
	anis - anise green - anisgrün	318836C	1	1 4
	sauge - sage - Salbei	194546C	1	1 4
	céladon - celadon - celadon	194547C	1	1 4
	paon - peacock - Pfau	194548C	1	1 4
	eau - aqua - aqua	194549C	1	1 4
	turquoise - turquoise blue - türkis	318837C	1	1 4
	bleu nuit - midnight - mitternachtsblau	194550C	1	1 4
	saphir - sapphire blue - saphirblau	318838C	1	1 4
	iris - iris	318839C	1	1 4
	violet - purple - violett	318930C	1	1 4
	lilas - lilac - Lilie	318931C	1	1 4
	fuchsia - Fuchsie	194551C	1	1 4
	framboise - raspberry - himbeerrot	318932C	1	1 4
	coquelicot - poppy - Mohn	318933C	1	1 4
	corail - coral - Koralle	194552C	1	1 4
	tangerine - tangerin - Mandarine	318934C	1	1 4
	orange - orange	118830C	1	1 4
	jonquille - daffodil yellow - Narzisse	318936C	1	1 4



porte-étiquette
métallique
metallic label
holder



Filmé individuellement - Individually shrink-wrapped - Einzeln in Folie eingeschweißt



porte-étiquette métallique
metal label holder
Etikettenhalter aus Metall

Photos non contractuelles - Photos are not contractually binding - Bild vertraglich nicht bindend

RHODIARAMA

Sous-main souples

Soft desk pads

Weiche Schreibtischunterlagen

- Recto et verso en simili cuir italien, logo Rhodia embossé, piqûres sellier orange
- Italian leatherette front and back, embossed Rhodia logo, orange saddle stitching
- Vorder- und Rückseite aus italienischem Kunstleder, geprägtes Rhodia-Logo, orangefarbene Sattelstiche



3 formats disponibles
3 sizes available
3 Formate erhältlich

S : 60 x 35 cm
M : 80 x 40 cm
L : 90 x 43 cm

16
couleurs
colors
Farben



patte de fermeture en simili cuir assorti
avec bouton métallique
metal button closure leatherette fastener
passende Verschlusslasche aus Kunstleder
mit Metallknopf

		S 60 x 35	M 80 x 40	L 90 x 43	MINI	📦
🟡	or - gold - gold	194230C	194264C	194307C	1	1
🟤	cuirre - copper - Kupfer	194231C	194265C	194308C	1	1
🟢	bronze- bronze - bronze	194232C	194266C	194309C	1	1
🟠	titane - titanium - Titan	194233C	194267C	194310C	1	1
🟡	argent - silver - silber	194234C	194268C	194311C	1	1
⚫	noir - black - schwarz	194235C	194269C	194312C	1	1
🟤	taupe - taupe	194237C	194270C	194313C	1	1
🟠	lie de vin - burgundy - Burgund	194238C	194271C	194314C	1	1
🟡	nacarat - orangerot	194239C	194272C	194315C	1	1
🟢	bois de rose - rosewood - Rosendunst	194240C	194273C	194316C	1	1
🟠	sauge - sage - Salbei	194241C	194274C	194317C	1	1
🟡	céladon - celadon - celadon	194242C	194275C	194318C	1	1
🟢	paon - peacock - Pfau	194243C	194276C	194319C	1	1
🟠	eau - aqua - aqua	194244C	194277C	194320C	1	1
🟡	bleu nuit - midnight - mitternachtsblau	194245C	194278C	194321C	1	1
🟢	coquelicot - poppy - Mohn	194246C	194279C	194322C	1	1



Livré dans un coffret en kraft - Delivered in a kraft box - Geliefert in einer Kraftkarton-Box



verso en simili cuir italien orange
Italian leatherette back orange
Rückseite aus italienischem Kunstleder in Orange

Photos non contractuelles - Photos are not contractual binding - Bild vertraglich nicht bindend

RHODIARAMA

Sous-main rigide

Hardback desk pad

Feste Schreibtischunterlage

- Recto en simili cuir italien, logo Rhodia embossé, piqûres sellier orange
- Italian leatherette, embossed Rhodia logo, orange saddle stitching
- Vorderseite aus italienischem Kunstleder, geprägtes Rhodia-Logo, orangefarbene Sattelstiche

60 x 40		MINI		
	or - gold - gold	194475C	1	1 10
	cuirre - copper - Kupfer	194476C	1	1 10
	bronze- bronze - bronze	194477C	1	1 10
	titane - titanium - Titan	194478C	1	1 10
	argent - silver - silber	318801C	1	1 10
	noir - black - schwarz	118806C	1	1 10
	chocolat - chocolate - Schokobraun	318803C	1	1 10
	taupe - taupe	318804C	1	1 10
	beige - beige	318805C	1	1 10
	lie de vin - burgundy - Burgund	194479C	1	1 10
	nacarat - orangerot	194480C	1	1 10
	bois de rose - rosewood - Rosenholz	194481C	1	1 10
	touche de rose - rose smoke - Rosendunst	194482C	1	1 10
	anis - anise green - anisgrün	318806C	1	1 10
	sauge - sage - Salbei	194483C	1	1 10
	céladon - celadon - celadon	194484C	1	1 10
	paon - peacock - Pfau	194485C	1	1 10
	eau - aqua - aqua	194486C	1	1 10
	turquoise - turquoise blue - türkis	318807C	1	1 10
	bleu nuit - midnight - mitternachtsblau	194487C	1	1 10
	saphir - sapphire blue - saphirblau	318808C	1	1 10
	iris - iris	318809C	1	1 10
	violet - purple - violett	318900C	1	1 10
	lilas - lilac - Lilie	318901C	1	1 10
	fuchsia - Fuchsie	194488C	1	1 10
	framboise - raspberry - himbeerrot	318902C	1	1 10
	coquelicot - poppy - Mohn	318903C	1	1 10
	corail - coral - Koralle	194489C	1	1 10
	tangerine - tangerin - Mandarine	318904C	1	1 10
	orange - orange	118800C	1	1 10
	jonquille - daffodil yellow - Narzisse	318906C	1	1 10

Filmé individuellement - Individually shrink-wrapped - Einzeln in Folie eingeschweißt

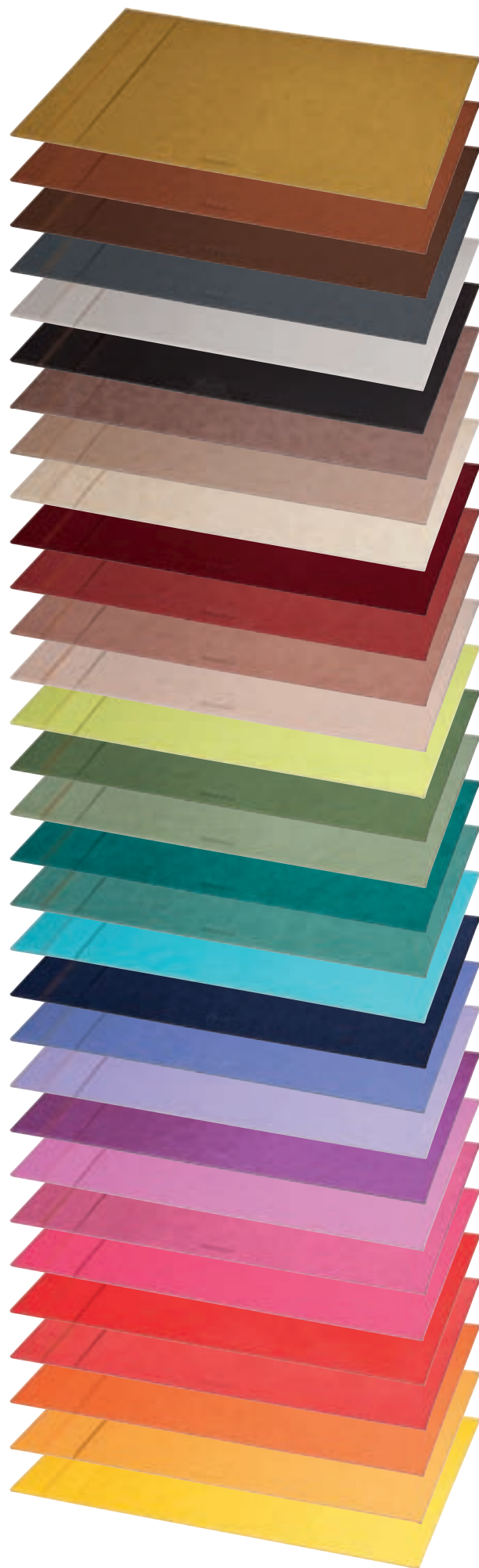

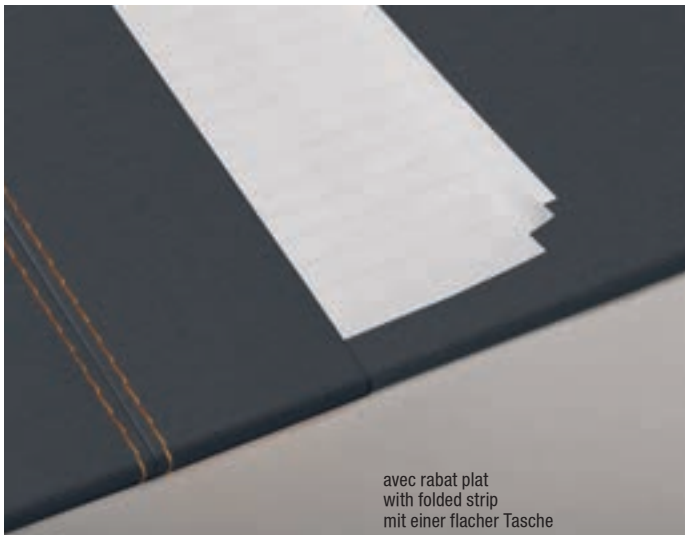

avec rabat plat
with folded strip
mit einer flacher Tasche

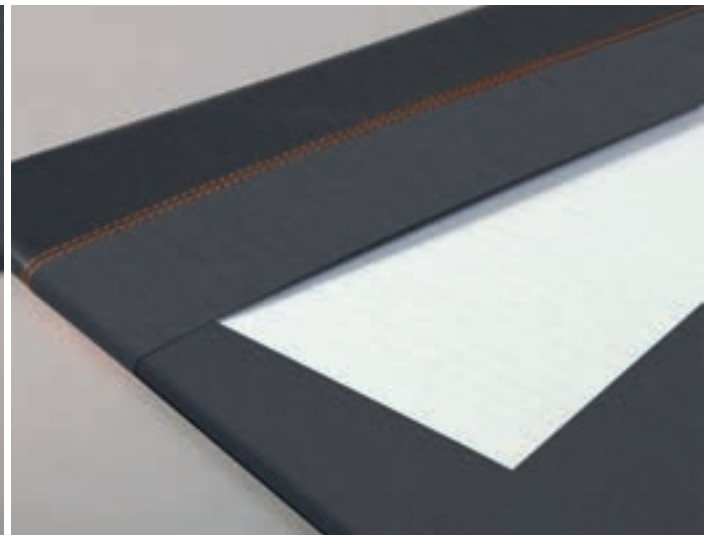

Photos non contractuelles - Photos are not contractually binding - Bild vertraglich nicht bindend

Corbeille

Waste bin

Papierkorb

- Extérieur en simili cuir italien, logo Rhodia embossé, piqûres sellier orange
- Italian leatherette, embossed Rhodia logo, orange saddle stitching
- Italienisches Kunstleder, geprägtes Rhodia-Logo, orangefarbene Sattelstiche



	24 x 24 x 32		MINI		
	or - gold - gold	194615C	1	1	3
	cuivre - copper - Kupfer	194616C	1	1	3
	bronze - bronze - bronze	194617C	1	1	3
	titane - titanium - Titan	194618C	1	1	3
	argent - silver - silber	318821C	1	1	3
	noir - black - schwarz	118826C	1	1	3
	chocolat - chocolate - Schokobraun	318823C	1	1	3
	taupe - taupe	318824C	1	1	3
	beige - beige	318825C	1	1	3
	lie de vin - burgundy - Burgund	194619C	1	1	3
	nacarat - orangerot	194620C	1	1	3
	bois de rose - rosewood - Rosenholz	194621C	1	1	3
	touche de rose - rose smoke - Rosendunst	194622C	1	1	3
	anis - anise green - anisgrün	318826C	1	1	3
	sauge - sage - Salbei	194623C	1	1	3
	céladon - celadon - celadon	194624C	1	1	3
	paon - peacock - Pfau	194625C	1	1	3
	eau - aqua - aqua	194626C	1	1	3
	turquoise - turquoise blue - türkis	318827C	1	1	3
	bleu nuit - midnight - mitternachtsblau	194627C	1	1	3
	saphir - sapphire blue - saphirblau	318828C	1	1	3
	iris - iris	318829C	1	1	3
	violet - purple - violett	318920C	1	1	3
	lilas - lilac - Lilie	318921C	1	1	3
	fuchsia - Fuchsie	194628C	1	1	3
	framboise - raspberry - himbeerrot	318922C	1	1	3
	coquelicot - poppy - Mohn	318923C	1	1	3
	corail - coral - Koralle	194629C	1	1	3
	tangerine - tangerin - Mandarine	318924C	1	1	3
	orange - orange	118820C	1	1	3
	jonquille - daffodil yellow - Narzisse	318926C	1	1	3



Filmé individuellement - Individually shrink-wrapped - Einzel in Folie eingeschweißt



Photos non contractuelles - Photos are not contractually binding - Bild vertraglich nicht bindend

RHODIARAMA

Trieur 4 tiroirs

4 drawers storage box

Aufbewahrungsbox mit 4 Schubladen

- Extérieur en simili cuir italien, logo Rhodia embossé, piqûres sellier orange, boutons en métal
- Italian leatherette outside, embossed Rhodia logo, orange saddle stitching, metallic knobs
- Außenseite aus italienischem Kunstleder, geprägtes Rhodia-Logo, orangefarbene Sattlerstiche, Metallknöpfe



24,8 x 32,7 x 22,8		MINI			
	or - gold - gold	194568C	1	1	2
	cuivre - copper - Kupfer	194569C	1	1	2
	bronze - bronze - bronze	194570C	1	1	2
	titane - titanium - Titan	194571C	1	1	2
	argent - silver - silber	318861C	1	1	2
	noir - black - schwarz	118866C	1	1	2
	chocolat - chocolate - Schokobraun	318863C	1	1	2
	taupe - taupe	318864C	1	1	2
	beige - beige	318865C	1	1	2
	lie de vin - burgundy - Burgund	194572C	1	1	2
	nacarat - orangerot	194573C	1	1	2
	bois de rose - rosewood - Rosenholz	194574C	1	1	2
	touche de rose - rose smoke - Rosendunst	194575C	1	1	2
	anis - anise green - anisgrün	318866C	1	1	2
	sauge - sage - Salbei	194576C	1	1	2
	céladon - celadon - celadon	194577C	1	1	2
	paon - peacock - Pfau	194578C	1	1	2
	eau - aqua - aqua	194579C	1	1	2
	turquoise - turquoise blue - türkis	318867C	1	1	2
	bleu nuit - midnight - mitternachtsblau	194580C	1	1	2
	saphir - sapphire blue - saphirblau	318868C	1	1	2
	iris - iris	318869C	1	1	2
	violet - purple - violett	318960C	1	1	2
	lilas - lilac - Lilie	318961C	1	1	2
	fuchsia - Fuchsie	194581C	1	1	2
	framboise - raspberry - himbeerrot	318962C	1	1	2
	coquelicot - poppy - Mohn	318963C	1	1	2
	corail - coral - Koralle	194582C	1	1	2
	tangerine - tangerin - Mandarine	318964C	1	1	2
	orange - orange	118860C	1	1	2
	jonquille - daffodil yellow - Narzisse	318966C	1	1	2

boutons métalliques
metal knobs
Metallknöpfe



Filmé individuellement - Individually shrink-wrapped - Einzeln in Folie eingeschweißt



piqûres sellier orange
orange saddle stitching
orangefarbene Sattelstiche

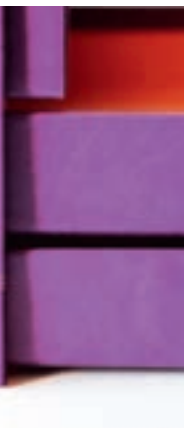

logo Rhodia embossé
embossed Rhodia logo
Geprägtes Rhodia-Logo



boutons métalliques
metal knobs
Metallknöpfe



Set de 5 boîtes gigognes

Set of 5 nested boxes

Set aus 5 Boxen

- Extérieur en simili cuir italien, logo Rhodia embossé, piqûres sellier orange
- Italian leatherette, embossed Rhodia logo, orange saddle stitching
- Italienisches Kunstleder, geprägtes Rhodia-Logo, orangefarbene Sattelstiche

small / klein - 10 x 15 x 10
 carré / quadratisch - 16 x 16 x 11
 carré / quadratisch - 20 x 20 x 11
 medium / mittel - 38 x 24 x 13
 large / groß - 44 x 34 x 16



			MINI		
	or - gold - gold	194553C	1	1	2
	cuivre - copper - Kupfer	194554C	1	1	2
	bronze - bronze - bronze	194555C	1	1	2
	titane - titanium - Titan	194556C	1	1	2
	argent - silver - silber	318881C*	1	1	2
	noir - black - schwarz	118886C	1	1	2
	chocolat - chocolate - Schokobraun	318883C	1	1	2
	taupe - taupe	318884C	1	1	2
	beige - beige	318885C*	1	1	2
	lie de vin - burgundy - Burgund	194560C	1	1	2
	nacarat - orangerot	194561C	1	1	2
	bois de rose - rosewood - Rosenholz	194562C	1	1	2
	touche de rose - rose smoke - Rosendunst	194563C	1	1	2
	anis - anise green - anisgrün	318886C*	1	1	2
	sauge - sage - Salbei	194564C	1	1	2
	céladon - celadon - celadon	194565C	1	1	2
	paon - peacock - Pfau	194566C	1	1	2
	eau - aqua - aqua	194567C	1	1	2
	turquoise - turquoise blue - türkis	318887C	1	1	2
	bleu nuit - midnight - mitternachtsblau	194557C	1	1	2
	saphir - sapphire blue - saphirblau	318888C*	1	1	2
	iris - iris	318889C*	1	1	2
	violet - purple - violett	318980C*	1	1	2
	lilas - lilac - Lilie	318981C*	1	1	2
	fuchsia - Fuchsie	194558C	1	1	2
	framboise - raspberry - himbeerrot	318982C*	1	1	2
	coquelicot - poppy - Mohn	318983C	1	1	2
	corail - coral - Koralle	194559C	1	1	2
	tangerine - tangerin - Mandarine	318984C*	1	1	2
	orange - orange	118880C	1	1	2
	jonquille - daffodil yellow - Narzisse	318986C*	1	1	2

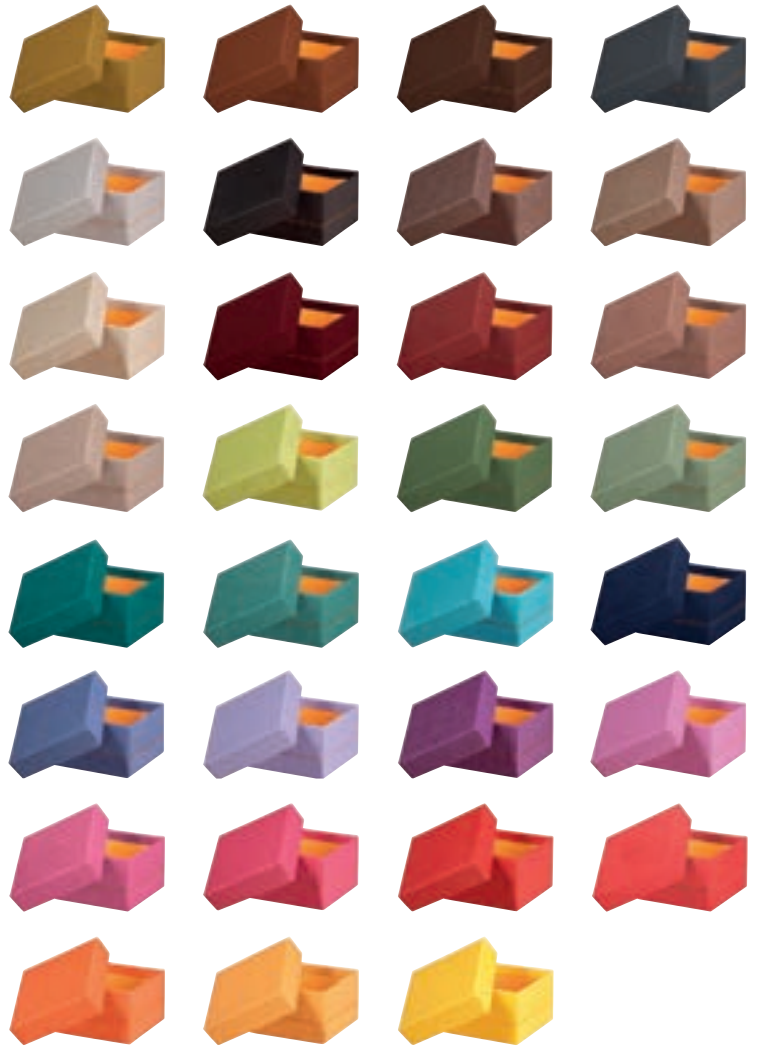

Set de 5 boîtes filmé - Wrapped set of 5 boxes - Foliiertes Set aus 5 Boxen



Photos non contractuelles - Photos are not contractually binding - Bild vertraglich nicht bindend

RHODIARAMA



Papiers d'exception Art & création Calligraphie

Exceptional papers - Drawing and sketching - Calligraphy
Außergewöhnliche Papiere - Zeichnen und Skizzieren - Kalligraphie



Photos non contractuelles - Photos et couleurs d'illustration non contractuelles. Rhodia est une marque déposée de Rhodia. © 2019 Rhodia. Tous droits réservés.

RHODIA TOUCH

rhodia touch

À chaque art son papier, à chaque papier sa subtilité!

La collection Rhodia Touch offre aux calligraphes, urban sketchers, designers, architectes, illustrateurs ou aquarelistes, des carnets, cahiers et blocs pertinents et pensés spécialement pour eux.

Depuis toujours, nous maîtrisons l'art du papier.

Fabriqués avec le plus grand soin au sein de nos manufactures en France et aux Pays-Bas, les incomparables papiers beaux-arts Clairefontaine au cœur des produits Rhodia Touch en font les supports de choix de tous les amoureux de papiers d'exception.

Ce savoir-faire papetier, conjugué au succès international avéré et à la réputation sans faille de la marque Clairefontaine dans le domaine des beaux-arts, constituent les précieux labels qualité de cette gamme.

For every art its paper, for each paper its subtlety!

Rhodia Touch is a collection of convenient notebooks and artbooks designed especially for calligraphers, urban sketchers, designers, architects, illustrators and watercolorists.

We have always been experts in the art of papermaking, and it is precisely because our fine arts papers are crafted with the greatest care in our very own paper mills in France and the Netherlands, that Rhodia Touch articles will be favored by all paper connoisseurs.

This range carries the hallmark of excellence, reflecting both our papermaking expertise and the Clairefontaine brand's proven track record and outstanding reputation in fine arts.

Jeder Kunst ihr Papier, jedem Papier seine Subtilität!

Die Rhodia Touch-Kollektion bietet Kalligrafen, Stadtplanern, Designern, Architekten, Illustratoren oder Aquarellisten relevante und speziell für sie entworfene Notizbücher, Hefte und Blöcke.

Seit jeher beherrschen wir die Kunst des Papiermachens.

Das unvergleichliche Clairefontaine-Kunstdruckpapier, das in unseren Manufakturen in Frankreich und den Niederlanden mit größter Sorgfalt hergestellt wird, ist das Herzstück der Rhodia Touch-Produkte und macht sie zur ersten Wahl für alle, die außergewöhnliches Papier lieben.

Dieses Know-how in der Papierherstellung, der nachgewiesene internationale Erfolg und der makellose Ruf der Marke Clairefontaine im Bereich der bildenden Künste sind die wertvollen Qualitätssiegel dieser Produktreihe.



Réglures

En exclusivité, Rhodia vous présente deux nouvelles réglures irrésistibles, à la fois esthétiques et ultra-pratiques. Pour celles et ceux qui préfèrent allier l'agréable à l'utile !

Cross

De délicates petites croix composent cette réglure originale et élégante, qui autorise confort et spontanéité dans la création. Cette grille géométrique sobre et harmonieuse est un support idéal pour vous aider sans vous gêner.

Le plus : ce quadrillage gracile sait se faire oublier au scanner, au photocopieur ou lorsque photographié ou filmé.

Delicate little crosses make up this original and elegant ruling, which allows comfort and spontaneity in the creation. This simple and harmonious geometric grid is an ideal support to help you without disturbing you.

The little extra: the finesse of this light grid allows it to be forgotten by the scanner, copier or when photographed or filmed.

Feine kleine Kreuze bilden diese originelle und elegante Lineatur, die Komfort und Spontaneität bei der Gestaltung ermöglicht. Dieses schlichte und harmonische geometrische Raster ist eine ideale Unterstützung, um Ihnen zu helfen, ohne Sie zu behindern.

Der Clou: Dieses grazile Raster ist beim Scannen, Kopieren oder Drucken nicht sichtbar.



Rulings

New and exclusive! Introducing two irresistible rulings, both aesthetic and ultra-practical.

For those who prefer to combine the pleasant with the useful!

Cross'n'Dot

Une réglure novatrice tout en retenue et raffinement, pour marier le plaisir et l'aisance de la création sur une subtile dentelle alternant tous les 5 mm petites croix ouvertes et petits points discrets.

Le plus : cette matrice délicate sait se rendre quasiment imperceptible au scanner, au photocopieur ou lorsque photographiée ou filmée.

An innovative, clean and refined ruling to combine the pleasure and ease of creation on a subtle lace alternating every 5 mm delicate small open crosses and small discreet dots.

The little extra: this graceful matrix can make itself almost imperceptible to the scanner, copier or when photographed or filmed.

Eine innovative, zurückhaltende und raffinierte Lineatur, um Freude und Einfachheit beim Gestalten auf einer subtilen Ebene zu erleichtern, die alle 5 mm zwischen kleinen offenen Kreuzen und kleinen unauffälligen Stichen wechselt.

Der Vorteil: Diese zarte Matrix ist beim Scannen, Kopieren, Fotografieren oder Filmen kaum wahrnehmbar.



Aquarelle \ nom féminin

(italien *acquarello*, du latin *aquarius*, relatif à l'eau)

1. Peinture délayée à l'eau, légère, transparente, appliquée le plus souvent sur du papier blanc.

2. Œuvre obtenue à l'aide d'une telle peinture.

L'aquarelle apparaît, en Europe, au XVe s., et devient un genre autonome vers la seconde moitié du XVIIIe s.)

Watercolor \ feminine name

(Italian *acquarello*, from Latin *aquarius*, relating to water)

1. A paint diluted with water, light, transparent, usually applied on white paper.

2. Work obtained with such a paint. (Watercolor appeared in Europe in the 15th century and became an independent genre in the second half of the 18th century)

Aquarell \ weiblicher Name

(italienisch *acquarello*, von lateinisch *aquarius*, das sich auf das Wasser bezieht)

1. Eine mit Wasser verdünnte, leichte, transparente Farbe, die gewöhnlich auf weißes Papier aufgetragen wird.

2. Die mit einer solchen Farbe hergestellten Arbeiten. (Das Aquarell kam in Europa im 15. Jahrhundert auf und wurde in der zweiten Hälfte des 18. Jahrhunderts zu einer eigenständigen Gattung)

Traditionnellement, les papiers beaux-arts étaient tous faits à base de coton, ce qui leur garantissait la meilleure stabilité dans le temps. De nos jours, les techniques ont considérablement perfectionné les papiers à base de cellulose de bois, leur conférant les mêmes qualités de conservation. Toutefois, les fibres de coton étant creuses, les papiers à base de coton ont une meilleure capacité d'absorption, particulièrement intéressante en aquarelle. Le papier Fontaine 100 % pur coton choisi pour la gamme aquarelle Touch répond ainsi aux attentes des aquarellistes les plus exigeants : absorption, planéité du papier mouillé, possibilité de repentir* y compris sur le demi-satiné.

*possibilité d'effacer une trace de peinture.

Traditionally, fine art papers were all made from cotton, which guaranteed them the best stability over time. Nowadays, techniques have considerably improved the wood cellulose based papers, giving them the same conservation qualities. However, since cotton fibers are hollow, cotton-based papers have a better absorption capacity, which is particularly interesting in watercolor. The Fontaine 100 % pure cotton paper chosen for the Touch watercolor range meets the expectations of the most demanding watercolorists: absorption, flatness of the wet paper, possibility of repentance* even on the semi-satin.

*possibility of erasing a trace of paint.

Traditionell bestanden alle Kunstdruckpapiere aus Baumwolle, was ihnen die beste Stabilität im Laufe der Zeit garantierte. Heutzutage haben die Techniken die auf Holzzellstoff basierenden Papiere erheblich verbessert, so dass sie die gleichen Konservierungseigenschaften aufweisen. Da die Baumwollfasern jedoch hohl sind, haben Papiere auf Baumwollbasis ein besseres Absorptionsvermögen, was besonders für Aquarelle interessant ist. Das Fontaine-Papier aus 100 % reiner Baumwolle, das für die Aquarellserie Touch ausgewählt wurde, erfüllt die Erwartungen der anspruchsvollsten Aquarellisten: Absorption, Flachheit des nassen Papiers, Möglichkeit der Retusche* sogar auf dem halbsatinierten Papier.

*Möglichkeit, eine Farbspur zu löschen.



rhodia touch



Watercolor Book - grain satiné

Watercolor Book - hot-pressed

Watercolor Book - satiniert gekörnt



Papier aquarelle Fontaine grain satiné 100 % pur coton
300 g/m² fabriqué aux Pays-bas

- Brochure cousue rembordée rigide
- Couverture toile noire imprimée, fermeture à élastique
- Embossage logo Rhodia Touch au recto
- 40 pages non microperforées
- Ruban marque-page et pochette à soufflet
- Pages de garde noires

140 lb Fontaine 100% cotton hot-pressed watercolor paper made in the Netherlands

- Hardback artbook
- Black printed fabric hardcover, elastic closure
- Rhodia Touch logo embossed on front cover
- 20 non microperforated sheets
- Ribbon bookmark and expanding inner pocket
- Black front and back pages

Satiniert gekörntes Fontaine Aquarellpapier 300 g/m² aus 100 % reine Baumwolle, hergestellt in den Niederlanden

- Genähte Broschüre mit festem Umschlag
- Bedruckter schwarzer Leineneinband, Gummizugverschluss
- Prägung Rhodia Touch-Logo auf der Vorderseite
- 20 nicht mikroperforierte Blätter
- Lesezeichenband und Faltentasche
- Schwarze Deckseiten



Format - Size	Uni - Blank - Blanko	MINI	
A6 paysage - landscape - Querformat	116154C	2	1
A5 paysage - landscape - Querformat	116155C	2	1
A4 paysage - landscape - Querformat	116156C	2	1
A6 portrait - Hochformat	116157C	2	1
A5 portrait - Hochformat	116158C	2	1
A4 portrait - Hochformat	116159C	2	1
15 x 15	116160C	2	1
21 x 21	116161C	2	1



fermeture à élastique noir
black elastic closure
schwarzer Gummizugverschluss

Filmé individuellement - Individually shrink-wrapped - Einzeln in Folie eingeschweißt

Fabriqué aux Pays-Bas par Schut, le papier aquarelle Fontaine grain satiné est un papier 100 % coton à base de gélatine naturelle. Son grain satiné, pressé à chaud, offre une texture lisse particulièrement adaptée à la réalisation d'œuvres aquarelles détaillées et précises. Il se prête également très bien au mélange de techniques.

Made in the Netherlands by Schut, Fontaine hot-pressed watercolor paper is a 100 % cotton paper made from natural gelatin. Its satin grain, hot pressed, offers a smooth texture particularly adapted to the realization of detailed and precise watercolor works. It's also a perfect mixed media surface which gives brightness and shine to pigments.

Das in den Niederlanden von Schut hergestellte satiniert gekörnte Fontaine Aquarellpapier ist ein Papier aus 100 % Baumwolle auf der Basis von natürlicher Gelatine. Seine satinierte Körnung, die heiß gepresst wird, bietet eine glatte Textur, die sich besonders für detaillierte und präzise Aquarellarbeiten eignet. Es eignet sich auch sehr gut zum Mischen von Techniken.



Photos non contractuelles - Photos are not contractually binding - Bild vertraglich nicht bindend

RHODIA TOUCH

rhodia touch

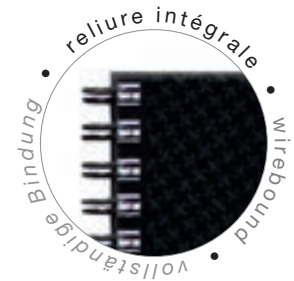

Watercolor Book - grain satiné

Watercolor Book - hot-pressed

Watercolor Book - satiniert gekörnt



Papier aquarelle Fontaine grain satiné 100 % pur coton
300 g/m² fabriqué aux Pays-bas

- Reliure intégrale rigide
- Couverture toile noire imprimée
- Embossage logo Rhodia Touch au recto
- 40 pages non microperforées
- Pages de garde noires

140 lb Fontaine 100% cotton hot-pressed watercolor paper made in the Netherlands

- Hardback wirebound artbook
- Black printed fabric hardcover
- Rhodia Touch logo embossed on front cover
- 20 non microperforated sheets
- Black front and back pages



A4

A5

A6

Satiniert gekörntes Fontaine Aquarellpapier 300 g/m²
aus 100 % reiner Baumwolle, hergestellt in den
Niederlanden

- Integraler fester Umschlag
- Bedruckter schwarzer Leineneinband
- Prägung Rhodia Touch-Logo auf der Vorderseite
- 20 nicht mikroperforierte Blätter
- Schwarze Deckseiten



Format - Size	Uni - Blank - Blanko	MINI	📦
A6 paysage - landscape - Querformat	116162C	2	1
A5 paysage - landscape - Querformat	116163C	2	1
A4 paysage - landscape - Querformat	116164C	2	1
A6 portrait - Hochformat	116165C	2	1
A5 portrait - Hochformat	116166C	2	1
A4 portrait - Hochformat	116167C	2	1
15 x 15	116168C	2	1
21 x 21	116169C	2	1



PEFC® 10-31-714



Filmé individuellement - Individually shrink-wrapped - Einzeln in Folie eingeschweißt

Fabriqué aux Pays-Bas par Schut, le papier aquarelle Fontaine grain satiné est un papier 100 % coton à base de gélatine naturelle. Son grain satiné, pressé à chaud, offre une texture lisse particulièrement adaptée à la réalisation d'œuvres aquarelles détaillées et précises. Il se prête également très bien au mélange de techniques.

Made in the Netherlands by Schut, Fontaine hot-pressed watercolor paper is a 100 % cotton paper made from natural gelatin. Its satin grain, hot pressed, offers a smooth texture particularly adapted to the realization of detailed and precise watercolor works. It's also a perfect mixed media surface which gives brightness and shine to pigments.

Das in den Niederlanden von Schut hergestellte satiniert gekörnte Fontaine Aquarellpapier ist ein Papier aus 100 % Baumwolle auf der Basis von natürlicher Gelatine. Seine satinierte Körnung, die heiß gepresst wird, bietet eine glatte Textur, die sich besonders für detaillierte und präzise Aquarellarbeiten eignet. Es eignet sich auch sehr gut zum Mischen von Techniken.



rhodia touch

Watercolor Book - grain fin

Watercolor Book - cold-pressed

Watercolor Book - fein gekörnt



Papier aquarelle Fontaine 100 % coton grain fin 300 g/m² fabriqué aux Pays-bas

- Brochure cousue rembordée rigide
- Couverture toile noire imprimée, fermeture à élastique
- Embossage logo Rhodia Touch au recto
- 40 pages non microperforées
- Ruban marque-page et pochette à soufflet
- Pages de garde noires

140 lb Fontaine 100 % cotton cold-pressed watercolor paper made in the Netherlands

- Hardback artbook
- Black printed fabric hardcover, elastic closure
- Rhodia Touch logo embossed on front cover
- 20 non microperforated sheets
- Ribbon bookmark and expanding inner pocket
- Black front and back pages

Fein gekörntes Fontaine Aquarellpapier 300 g/m² aus 100 % Baumwolle, hergestellt in den Niederlanden

- Genähte Broschüre mit festem Umschlag
- Bedruckter schwarzer Leineneinband, Gummizugverschluss
- Prägung Rhodia Touch-Logo auf der Vorderseite
- 20 nicht mikroperforierte Blätter
- Lesezeichenband und Faltentasche
- Schwarze Deckseiten



Format - Size	Uni - Blank - Blanko	MINI	
A6 paysage - landscape - Querformat	116136C	2	1
A5 paysage - landscape - Querformat	116137C	2	1
A4 paysage - landscape - Querformat	116138C	2	1
A6 portrait - Hochformat	116139C	2	1
A5 portrait - Hochformat	116140C	2	1
A4 portrait - Hochformat	116141C	2	1
15 x 15	116142C	2	1
21 x 21	116143C	2	1



fermeture à élastique noir
black elastic closure
schwarzer Gummizugverschluss

Filmé individuellement - Individually shrink-wrapped - Einzel in Folie eingeschweißt

Fabriqué aux Pays-Bas par Schut, le papier aquarelle Fontaine 100 % coton grain fin est de qualité professionnelle. Son grain fin, régulier et subtile, facile à utiliser, offre une large polyvalence. Très résistant au grattage, il a une excellente capacité d'absorption, permet le repentir. Il est sans azurant optique, sans acide et de pH neutre.

Made in the Netherlands by Schut, Fontaine 100 % cotton cold-pressed watercolor paper is a professional quality paper. Its fine grain, regular and subtle, easy to use, offers a wide versatility. Very resistant to scratching, it has an excellent absorption capacity, allows repentance. It is free of optical brightener, acid and neutral pH.

Das in den Niederlanden von Schut hergestellte feinkörnige Fontaine Aquarellpapier aus 100 % Baumwolle ist von professioneller Qualität. Seine feine, gleichmäßige und subtile Körnung, die einfach zu verwenden ist, bietet eine große Vielseitigkeit. Es ist besonders kratzfest, besitzt eine ausgezeichnete Saugfähigkeit, ermöglicht das Retuschieren. Es ist frei von optischen Aufhellern, säurefrei und pH-neutral.



rhodia touch

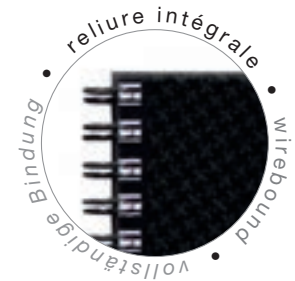

Watercolor Book - grain fin

Watercolor Book - cold-pressed

Watercolor Book - fein gekörnt



Papier aquarelle Fontaine 100 % coton grain fin 300 g/m² fabriqué aux Pays-bas

- Reliure intégrale rigide
- Couverture toile noire imprimée
- Embossage logo Rhodia Touch au recto
- 40 pages non microperforées
- Pages de garde noires

140 lb Fontaine 100 % cotton cold-pressed watercolor paper made in the Netherlands

- Hardback wirebound artbook
- Black printed fabric hardcover
- Rhodia Touch logo embossed on front cover
- 20 non microperforated sheets
- Black front and back pages

Fein gekörntes Fontaine Aquarellpapier 300 g/m² aus 100 % Baumwolle, hergestellt in den Niederlanden

- Integraler fester Einband
- Bedruckter schwarzer Leineneinband
- Prägung Rhodia Touch-Logo auf der Vorderseite
- 20 nicht mikroperforierte Blätter
- Schwarze Deckseiten



Format - Size	Uni - Blank	MINI	📦
A6 paysage - landscape - Querformat	116144C	2	1
A5 paysage - landscape - Querformat	116145C	2	1
A4 paysage - landscape - Querformat	116146C	2	1
A6 portrait - Hochformat	116147C	2	1
A5 portrait - Hochformat	116148C	2	1
A4 portrait - Hochformat	116149C	2	1
15 x 15	116150C	2	1
21 x 21	116151C	2	1



Filmé individuellement - Individually shrink-wrapped - Einzeln in Folie eingeschweißt

Fabriqué aux Pays-Bas par Schut, le papier aquarelle Fontaine 100 % coton grain fin est de qualité professionnelle. Son grain fin, régulier et subtile, facile à utiliser, offre une large polyvalence. Très résistant au grattage, il a une excellente capacité d'absorption, permet le repentir. Il est sans azurant optique, sans acide et de pH neutre.

Made in the Netherlands by Schut, Fontaine 100 % cotton cold-pressed watercolor paper is a professional quality paper. Its fine grain, regular and subtle, easy to use, offers a wide versatility. Very resistant to scratching, it has an excellent absorption capacity, allows repentance. It is free of optical brightener, acid and neutral pH.

Das in den Niederlanden von Schut hergestellte feinkörnige Fontaine Aquarellpapier aus 100 % Baumwolle ist von professioneller Qualität. Seine feine, gleichmäßige und subtile Körnung, die einfach zu verwenden ist, bietet eine große Vielseitigkeit. Es ist besonders kratzfest, besitzt eine ausgezeichnete Saugfähigkeit, ermöglicht das Retuschieren. Es ist frei von optischen Aufhellern, säurefrei und pH-neutral.





rhodia touch



Watercolor Book - grain fin

Watercolor Book - cold-pressed

Watercolor Book - fein gekörnt



Papier aquarelle Fontaine 100 % coton grain fin 300 g/m² fabriqué aux Pays-bas

- Carnet rigide double accordéon
- Couverture toile noire imprimée, fermeture à élastique
- Embossage logo Rhodia Touch au recto
- A6 : 32 pages (16 x 2) / A5 : 24 pages (12 x 2)

140 lb Fontaine 100 % cotton cold-pressed watercolor paper made in the Netherlands

- Hardback double accordion artbook
- Black printed fabric hardcover, elastic closure
- Rhodia Touch logo embossed on front cover
- A6 : 16 sheets (8 x 2) / A5 : 12 sheets (6 x 2)

Fein gekörntes Fontaine Aquarellpapier 300 g/m² aus 100 % Baumwolle, hergestellt in den Niederlanden

- Doppelakkordeon-Skizzenbuch mit festem Umschlag
- Bedruckter schwarzer Leineneinband, Gummizugverschluss
- Prägung Rhodia Touch-Logo auf der Vorderseite
- A6 : 16 Blatt (8 x 2) / A5 : 12 Blatt (6 x 2)

Format - Size	Uni - Blank - blanko	MINI	
A6 portrait - Hochformat	116152C	2	1
A5 portrait - Hochformat	116153C	2	1

Filmé individuellement - Individually shrink-wrapped - Einzeln in Folie eingeschweißt

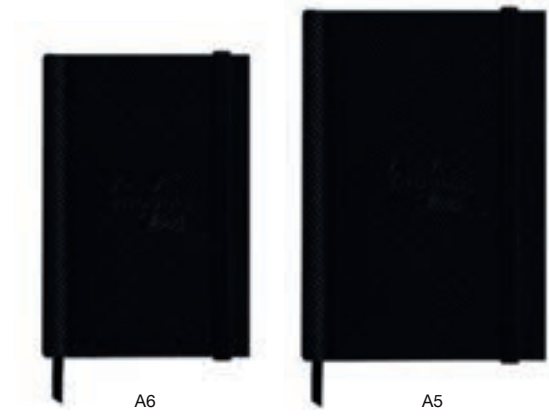

fermeture à élastique noir
black elastic closure
schwarzer Gummizugverschluss

Fabriqué aux Pays-Bas par Schut, le papier aquarelle Fontaine 100 % coton grain fin est de qualité professionnelle. Son grain fin, régulier et subtile, facile à utiliser, offre une large polyvalence. Très résistant au grattage, il a une excellente capacité d'absorption, permet le repentir. il est sans azurant optique, sans acide et de pH neutre.

Made in the Netherlands by Schut, Fontaine 100 % cotton cold-pressed watercolor paper is a professional quality paper. Its fine grain, regular and subtle, easy to use, offers a wide versatility. Very resistant to scratching, it has an excellent absorption capacity, allows repentance. It is free of optical brightener, acid and neutral pH.

Das in den Niederlanden von Schut hergestellte feinkörnige Fontaine Aquarellpapier aus 100 % Baumwolle ist von professioneller Qualität. Seine feine, gleichmäßige und subtile Körnung, die einfach zu verwenden ist, bietet eine große Vielseitigkeit. Es ist besonders kratzfest, besitzt eine ausgezeichnete Saugfähigkeit, ermöglicht das Retuschieren. Es ist frei von optischen Aufhellern, säurefrei und pH-neutral.



rhodia touch



Mixed Media Pad

Mixed Media sketchpad

skizzenblock Multitechnik



Papier multi-techniques Clairefontaine Paint'On extra-blanc 250 g/m² fabriqué en France

- Bloc encollé entoilé en-tête
- Couverture enveloppante carte Maya noire 270 g/m²
- Embossage logo Rhodia Touch au recto
- 20 feuillets microperforés détachables

115 lb extra white Clairefontaine Paint'On mixed media paper made in France

- Glued at the top, canvas-backed pad
- Maya black 126 lb card cover
- Rhodia Touch logo embossed on front cover
- 20 detachable microperforated sheets

Clairefontaine Paint'On Multitechnik-Papier extraweiß 250 g/m², hergestellt in Frankreich

- Geklebter und an Kopfende gespannter Block
- Vollständiger Umschlag aus schwarzem Maya-Karton 270 g/m²
- Prägung des Rhodia Touch-Logos auf der Vorderseite
- 20 mikroperforierte, abtrennbare Blätter

Format - Size	Uni - Blank - Blanko	MINI	
A6+portrait - Hochformat	116186C	2	1
A5+ portrait - Hochformat	116187C	2	1
A4+ portrait - Hochformat	116188C	2	1
A3+ paysage - landscape Querformat	116189C		

Filmé individuellement - Individually shrink-wrapped - Einzeln in Folie eingeschweißt

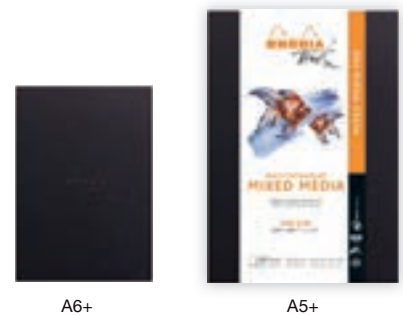

A6+

A5+



A4+



A3+



Fabriqué en France, le papier multi-techniques Clairefontaine Paint'On extra-blanc 100 % cellulose a un grain très léger qui se prête particulièrement aux travaux de détails. Son fort grammage et sa bonne capacité d'absorption le dédient aussi bien aux techniques sèches (crayon, feutre, stylo) qu'aux techniques humides (gouache, acrylique).

Made in France, Clairefontaine Paint'On extra white 100 % cellulose mixed media paper has a very light grain that is particularly suitable for detailed and precise work. Its high weight and good absorption capacity make it suitable for both dry techniques (pencil, felt pen, pen) and wet techniques (gouache, acrylic).

Das in Frankreich hergestellte Multitechnikpapier Clairefontaine Paint'On extraweiß aus 100 % Zellulose besitzt eine sehr leichte Körnung, die sich besonders für Detailarbeiten eignet. Seine hohe Grammat und seine gute Saugfähigkeit eignen sich sowohl für Trockentechniken (Bleistift, Filzstift, Kugelschreiber) als auch für Nasstechniken (Gouache, Acryl).



rhodia touch



Mixed Media Book

Mixed Media artbook

skizzenback Multitechnik



Papier multi-techniques Clairefontaine Paint'On extra-blanc 250 g/m² fabriqué en France

- Brochure cousue rembourée rigide
- Couverture toile noire imprimée, fermeture à élastique
- Embossage logo Rhodia Touch au recto
- 40 pages non microperforées
- Ruban marque-page et pochette à soufflet
- Pages de garde noires

115 lb extra white Clairefontaine Paint'On mixed media paper made in France

- Hardback artbook
- Black printed fabric hardcover, elastic closure
- Rhodia Touch logo embossed on front cover
- 20 non microperforated sheets
- Ribbon bookmark and expanding inner pocket
- Black front and back pages

Clairefontaine Paint'On Multitechnik-Papier extraweiß 250 g/m², hergestellt in Frankreich

- Genähte Broschüre mit festem Einband
- Bedruckter schwarzer Leineneinband, Umschlag Gummizugverschluss
- Prägung Rhodia Touch-Logo auf der Vorderseite
- 20 nicht mikroperforierte blätter
- Lesezeichenband und Faltentasche
- Schwarze Deckseiten

Format - Size	Uni - Blank - Blanco	MINI	📦
A6 paysage - landscape - Querformat	116170C	2	1
A5 paysage - landscape - Querformat	116171C	2	1
A4 paysage - landscape - Querformat	116172C	2	1
A6 portrait - Hochformat	116173C	2	1
A5 portrait - Hochformat	116174C	2	1
A4 portrait - Hochformat	116175C	2	1
15 x 15	116176C	2	1
21 x 21	116177C	2	1

Filmé individuellement - Individually shrink-wrapped - Einzeln in Folie eingeschweißt

Fabriqué en France, le papier multi-techniques Clairefontaine Paint'On extra-blanc 100 % cellulose a un grain très léger qui se prête particulièrement aux travaux de détails. Son fort grammage et sa bonne capacité d'absorption le dédient aussi bien aux techniques sèches (crayon, feutre, stylo) qu'aux techniques humides (gouache, acrylique).

Made in France, Clairefontaine Paint'On extra white 100 % cellulose mixed media paper has a very light grain that is particularly suitable for detailed and precise work. Its high weight and good absorption capacity make it suitable for both dry techniques (pencil, felt pen, pen) and wet techniques (gouache, acrylic).

Das in Frankreich hergestellte Multitechnikpapier Clairefontaine Paint'On extraweiß aus 100 % Zellulose besitzt eine sehr leichte Körnung, die sich besonders für Detailarbeiten eignet. Seine hohe Grammat und seine gute Saugfähigkeit eignen sich sowohl für Trockentechniken (Bleistift, Filzstift, Kugelschreiber) als auch für Nasstechniken (Gouache, Acryl).



A6

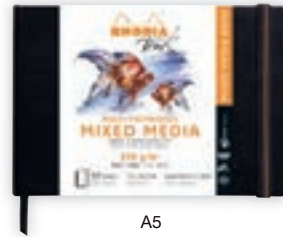

A5



A4



15x15 cm



21x21 cm

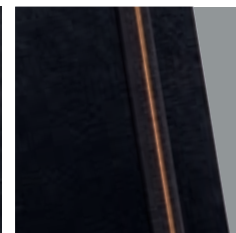
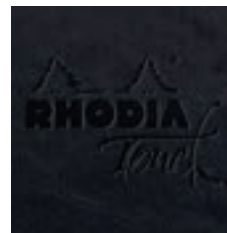

fermeture à élastique bicolore
two-colored elastic closure
zweifarbigiger Gummizugverschluss



© soofang

Photos non contractuelles - Photos are not contractually binding - Bild vertraglich nicht bindend.

RHODIA TOUCH

rhodia touch

Mixed Media Book

Mixed Media artBook

SkizzenBuch Multitechnik



Papier multi-techniques Clairefontaine Paint'On extra-blanc 250 g/m² fabriqué en France

- Couverture rigide à reliure intégrale
- Couverture toile noire imprimée, fermeture à élastique
- Embossage logo Rhodia Touch au recto
- 64 pages non microperforées
- Ruban marque-page et pochette à soufflet
- Pages de garde noires

115 lb extra white Clairefontaine Paint'On mixed media paper made in France

- Hardback wirebound artbook
- Black printed fabric hardcover, elastic closure
- Rhodia Touch logo embossed on front cover
- 32 non microperforated sheets
- Ribbon bookmark and expanding inner pocket
- Black front and back pages

Clairefontaine Paint'On Multitechnik-Papier extraweiß 250 g/m², hergestellt in Frankreich

- fester Umschlag mit durchgehender Bindung
- Bedruckter schwarzer Leineneinband, Gummizugverschluss
- Prägung Rhodia Touch-Logo auf der Vorderseite
- 32 nicht mikroperforierte Blätter
- Lesezeichenband und Faltentasche
- Schwarze Deckseiten

Format - Size	Uni - Blank - Blanko	MINI	📦
A6 paysage - landscape - Querformat	116178C	2	1
A5 paysage - landscape - Querformat	116179C	2	1
A4 paysage - landscape - Querformat	116180C	2	1
A6 portrait - Hochformat	116181C	2	1
A5 portrait - Hochformat	116182C	2	1
A4 portrait - Hochformat	116183C	2	1
15 x 15	116184C	2	1
21 x 21	116185C	2	1

Filmé individuellement - Individually shrink-wrapped - Einzeln in Folie eingeschweißt

Fabriqué en France, le papier multi-techniques Clairefontaine Paint'On extra-blanc 100 % cellulose a un grain très léger qui se prête particulièrement aux travaux de détails. Son fort grammage et sa bonne capacité d'absorption le dédient aussi bien aux techniques sèches (crayon, feutre, stylo) qu'aux techniques humides (gouache, acrylique).

Made in France, Clairefontaine Paint'On extra white 100 % cellulose mixed media paper has a very light grain that is particularly suitable for detailed and precise work. Its high weight and good absorption capacity make it suitable for both dry techniques (pencil, felt pen, pen) and wet techniques (gouache, acrylic).

Das in Frankreich hergestellte Multitechnikpapier Clairefontaine Paint'On extraweiß aus 100 % Zellulose besitzt eine sehr leichte Körnung, die sich besonders für Detailarbeiten eignet. Seine hohe Grammat und seine gute Saugfähigkeit eignen sich sowohl für Trockentechniken (Bleistift, Filzstift, Kugelschreiber) als auch für Nasstechniken (Gouache, Acryl).



A6



A5

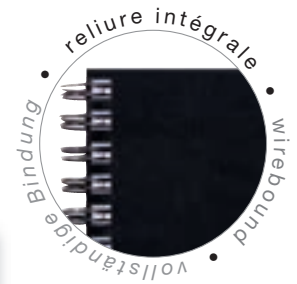

A4



15x15 cm



21x21 cm

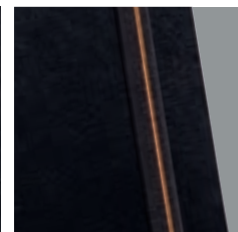
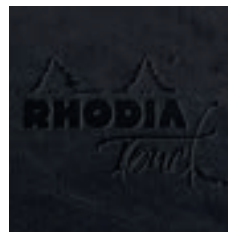

fermeture à élastique bicolore
two-colored elastic closure
zweifarbiges Gummizugverschluss



© ceekaygue

Photos non contractuelles - Photos are not contractually binding - Bild vertraglich nicht bindend

RHODIA TOUCH

rhodia touch

Marker Pad

Marker Pad

Markerblock



Papier Clairefontaine Layout blanc extra lisse 100 g/m² fabriqué aux Pays-bas

- Bloc encollé entoilé en-tête
- Couverture enveloppante carte Maya noire 270 g/m²
- Embossage logo Rhodia Touch au recto
- 50 feuillets microperforés détachables

45 lb Clairefontaine extra smooth white Layout paper made in the Netherlands

- Glued at the top, canvas-backed pad
- Maya black 126 lb card cover
- Rhodia Touch logo embossed on front cover
- 50 detachable microperforated sheets

Clairefontaine Layoutpapier weiß extraglatt 100 g/m² hergestellt in den Niederlanden

- Geklebter und am Kopfende gespannter Block
- Einband aus schwarzem Maya-Karton 270 g/m²
- Rhodia Touch geprägtes Logo auf der Vorderseite
- 50 mikroperforierte, abtrennbare Blätter

Format - Size - Format	Uni - Blank - Blanko	MINI		
A5+ portrait - Querformat	116100C	2	1	32
A4+ portrait - Querformat	116101C	2	1	16



A5+



A4



Filmé individuellement - Individually shrink-wrapped - Einzeln in Folie eingeschweißt



Fabriqué par Schut aux Pays-Bas, le papier Layout Clairefontaine 100 g/m² est dédié à la colorisation aux marqueurs à alcool. Très blanc et très lisse, il résiste parfaitement à la pénétration des encres. Les mélanges et les dégradés de couleurs se font aisément, sans craindre que l'encre ne transperce le papier. Il se gomme facilement et convient aussi pour le travail à la plume.

Made by Schut in the Netherlands, the Layout Clairefontaine 100 gsm paper is dedicated to colorization with alcohol markers. Very white and very smooth, it resists perfectly to the penetration of inks. Mixing and gradation of colors is easy, without fear that the ink will penetrate the paper. It is easily erased and is also suitable for pen and ink work.

Das von Schut in den Niederlanden hergestellte Layout-Papier 100 g/m² von Clairefontaine ist speziell für das Kolorieren mit Alkoholmarkern gedacht. Das Papier ist sehr weiß und glatt und widersteht dem Durchdringen von Tinte. Farbmischungen und -abstufungen lassen sich problemlos vornehmen, ohne dass man befürchten muss, dass die Tinte durch das Papier dringt. Es lässt sich leicht radieren und eignet sich auch für die Arbeit mit Federkielen.



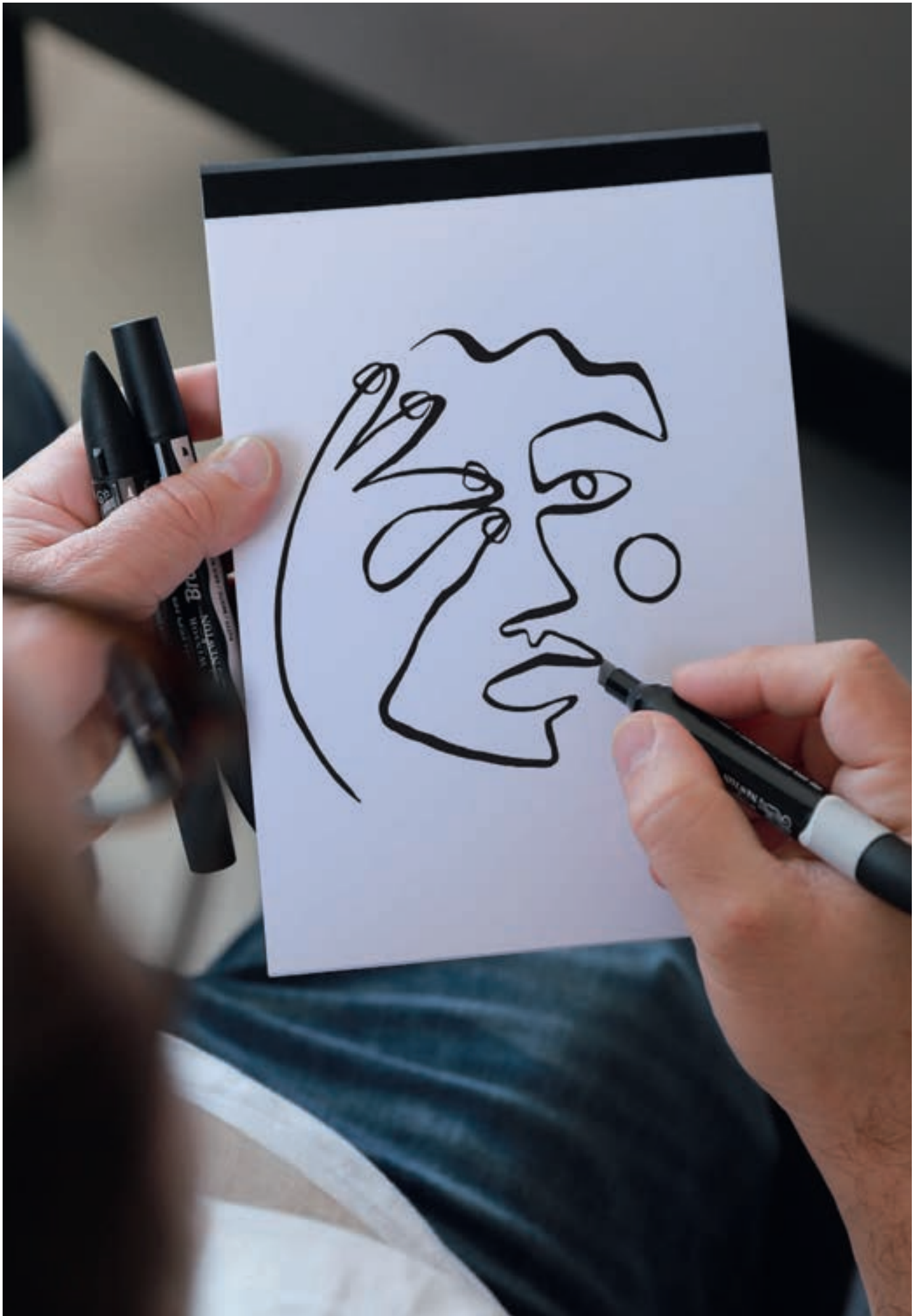

rhodia touch

White Maya® Pad

White Maya® Pad

Block White Maya®

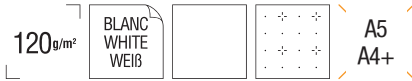

Papier Clairefontaine Maya® blanc lisse 120 g/m² fabriqué en France

- Bloc agrafé en-tête
- Couverture enveloppante rainée carte Maya noire 270 g/m²
- Embossage logo Rhodia Touch au recto
- 50 feuillets microperforés détachables
- Existe en uni et cross'n'dot

55 lb Clairefontaine smooth white Maya® paper made in France

- Head stapled pad
- Maya black 126 lb scored cover
- Rhodia Touch logo embossed on front cover
- 50 detachable microperforated sheets
- Comes in blank and cross'n'dot

Clairefontaine weißes glattes Maya®-Papier 120 g/m² hergestellt in Frankreich

- Am Kopfende gehefteter Block
- Gerillter, schwarzer Einband aus Maya-Karton 270 g/m²
- Rhodia Touch-Logoprägung auf der Vorderseite
- 50 mikroperforierte, abtrennbare Blätter
- Erhältlich in blanko und cross'n'dot.

Format - Size	Uni - Blank	Cross 'n' Dot	MINI		
A5 portrait - Hochformat	116102C	116103C	2	1	40
A4+ portrait - Hochformat	116104C	116105C	2	1	20

Filmé individuellement - Individually shrink-wrapped - Einzeln in Folie eingeschweißt



A5

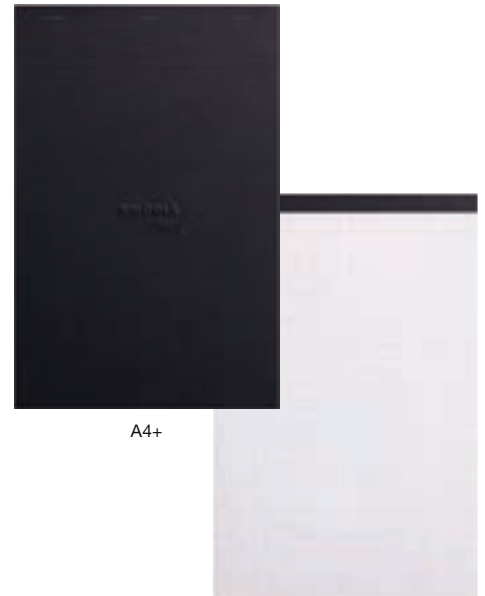
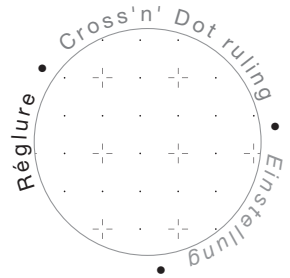

A4+



Fabriqué en France, Maya est un papier Clairefontaine lisse sur le recto et le verso, qui se prête parfaitement à l'art. Sa surface convient pour les dessins précis au crayon, feutre et encre. Les coloris, teintés dans la masse, sont résistants à la lumière, que ce soit le blanc, idéal pour faire ressortir l'éclat des couleurs, ou le gris ou le noir, pour jouer sur les contrastes. Fabriqué à base de colle végétale.

Made in France, Maya is a Clairefontaine paper that is smooth on the front and back and is perfect for art. Its surface is suitable for precise drawings with pencil, felt pen and ink. The deep dyed colors are resistant to light, whether white, ideal to bring out the brilliance of colors, or gray or black, to play on the contrasts. Vegan friendly.

Das in Frankreich hergestellte Maya-Papier ist ein auf Vorder- und Rückseite glattes Clairefontaine-Papier, das sich hervorragend für Kunstwerke eignet. Seine Oberfläche eignet sich für präzise Zeichnungen mit Bleistift, Filzstift und Tinte. Die Farben sind voll durchgefärbt und lichtbeständig. Weiß ist ideal, um die Leuchtkraft der Farben hervorzuheben, Grau oder Schwarz sind ideal, um mit Kontrasten zu spielen. Hergestellt auf der Basis von pflanzlichem Klebstoff.





rhodia touch

Grey Maya® Pad

Grey Maya® Pad

Block Grey Maya®

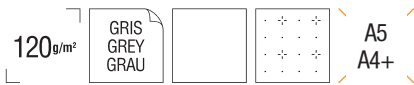

Papier Maya® gris lisse 120 g/m²

- Bloc agrafé en-tête
- Couverture enveloppante rainée carte Maya noire 270 g/m²
- Embossage logo Rhodia Touch au recto
- 50 feuillets microperforés détachables
- Existe en uni et cross'n'dot

55 lb smooth grey Maya® paper

- Head stapled pad
- Maya black 126 lb scored cover
- Rhodia Touch logo embossed on front cover
- 50 detachable microperforated sheets
- Comes in blank and cross'n'dot

Graues, glattes Maya®-Papier 120 g/m²

- Am Kopfende gehefteter Block
- Gerillter Einband aus schwarzem Maya-Karton 270 g/m²
- Rhodia Touch geprägtes Logo auf der Vorderseite
- 50 mikroperforierte, abtrennbare Blätter
- Erhältlich in Blanko und cross'n'dot

Format - Size	Uni - Blank	Cross 'n' Dot	MINI		
A5 portrait - Hochformat	116106C	116107C	2	1	40
A4+ portrait - Hochformat	116108C	116109C	2	1	20

Filmé individuellement - Individually shrink-wrapped - Einzeln in Folie eingeschweißt



A5

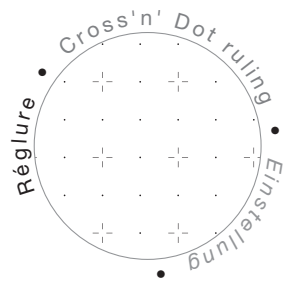

A4+



Fabriqué en France, Maya est un papier Clairefontaine lisse sur le recto et le verso, qui se prête parfaitement à l'art. Sa surface convient pour les dessins précis au crayon, feutre et encre. Les coloris, teintés dans la masse, sont résistants à la lumière, que ce soit le blanc, idéal pour faire ressortir l'éclat des couleurs, ou le gris ou le noir, pour jouer sur les contrastes. Fabriqué à base de colle végétale.

Made in France, Maya is a Clairefontaine paper that is smooth on the front and back and is perfect for art. Its surface is suitable for precise drawings with pencil, felt pen and ink. The deep dyed colors are resistant to light, whether white, ideal to bring out the brilliance of colors, or gray or black, to play on the contrasts. Vegan friendly.

Das in Frankreich hergestellte Maya-Papier ist ein auf Vorder- und Rückseite glattes Clairefontaine-Papier, das sich hervorragend für Kunstwerke eignet. Seine Oberfläche eignet sich für präzise Zeichnungen mit Bleistift, Filzstift und Tinte. Die Farben sind voll durchgefärbt und lichtbeständig. Weiß ist ideal, um die Leuchtkraft der Farben hervorzuheben, Grau oder Schwarz sind ideal, um mit Kontrasten zu spielen. Hergestellt auf der Basis von pflanzlichem Klebstoff.



© mishiechua

Photos non contractuelles - Photos are not contractually binding - Bild vertraglich nicht bindend

RHODIA TOUCH

rhodia touch

Black Maya® Pad

Black Maya® Pad

Block Black Maya®

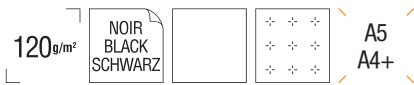

- Papier Clairefontaine Maya® noir lisse 120 g/m² fabriqué en France
- Bloc agrafé en-tête
 - Couverture enveloppante rainée carte Maya noire 270 g/m²
 - Embossage logo Rhodia Touch au recto
 - 50 feuillets microperforés détachables
 - Existe en uni et cross

- 55 lb Clairefontaine smooth black Maya® paper made in France
- Head stapled pad
 - Maya black 126 lb scored cover
 - Rhodia Touch logo embossed on front cover
 - 50 detachable microperforated sheets
 - Comes in blank and cross

Glattes schwarzes Clairefontaine Maya® Papier 120 g/m², hergestellt in Frankreich

- am Kopfende gehefteter Block
- gerilltes schwarzes Deckblatt aus Maya-Karton 270 g/m²
- Prägung Rhodia Touch-Logo auf der Vorderseite
- 50 mikroperforierte, abtrennbare Blätter
- Erhältlich in blanko und cross

Format - Size	Uni - Blank - Blanko	Cross	MINI		
A5 portrait / Hochformat	116110C	116111C	2	1	40
A4+ portrait / Hochformat	116112C	116113C	2	1	20

Filmé individuellement - Individually shrink-wrapped - Einzeln in Folie eingeschweißt



A5+

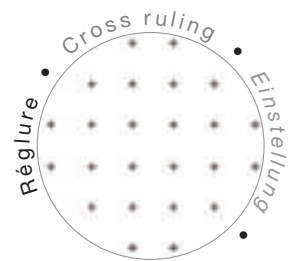

A4+



Fabriqué en France, Maya est un papier Clairefontaine lisse sur le recto et le verso, qui se prête parfaitement à l'art. Sa surface convient pour les dessins précis au crayon, feutre et encre. Les coloris, teintés dans la masse, sont résistants à la lumière, que ce soit le blanc, idéal pour faire ressortir l'éclat des couleurs, ou le gris ou le noir, pour jouer sur les contrastes. Fabriqué à base de colle végétale.

Made in France, Maya is a Clairefontaine paper that is smooth on the front and back and is perfect for art. Its surface is suitable for precise drawings with pencil, felt pen and ink. The deep dyed colors are resistant to light, whether white, ideal to bring out the brilliance of colors, or gray or black, to play on the contrasts.

Das in Frankreich hergestellte Clairefontaine-Papier Maya ist auf der Vorder- und Rückseite glatt und eignet sich hervorragend für Kunstwerke. Seine Oberfläche eignet sich für präzise Zeichnungen mit Bleistift, Filzstift und Tinte. Die Farben sind voll durchgefärbt und lichtbeständig. Sowohl Weiß, das ideal ist, um die Leuchtkraft der Farben hervorzuheben, als auch Grau oder Schwarz, um mit Kontrasten zu spielen. Hergestellt auf der Basis von pflanzlichem Klebstoff.





© starstray

Photos non contractuelles - Photos are not contractually binding - Bild vertraglich nicht bindend

RHODIA TOUCH

rhodia touch

Bristol book

Bristol sketchbook

Skizzenbuch Bristol



Papier Clairefontaine Bristol blanc extra lisse 205 g/m² fabriqué en France

- Brochure cousue souple dos carré collé
- Couverture en simili cuir italien, fermeture à élastique
- Embossage logo Rhodia Touch au recto
- 64 pages non microperforées
- Ruban marque-page

91 lb Clairefontaine extra smooth white Bristol paper made in France

- Softback artbook
- Italian leatherette softcover, elastic closure
- Rhodia Touch logo embossed on front cover
- 32 non microperforated sheets
- Ribbon bookmark

Extraglattes weißes Clairefontaine Bristol Papier 205 g/m², hergestellt in Frankreich

- weiche genähte Broschüre mit geklebtem Rücken
- Umschlag aus italienischem Kunstleder, Gummizugverschluss
- Prägung Rhodia Touch-Logo auf der Vorderseite
- 64 nicht mikroperforierte Seiten
- Lesezeichenband

Format - Size	Uni - Blank - Blanko	MINI			
A5 paysage - landscape - Querformat	116114C	2	1	20	40
A4 portrait / Hochformat	116115C	2	1	10	20

Filmé individuellement - Individually shrink-wrapped - Einzeln in Folie eingeschweißt



A5



A4



fermeture à élastique bicolore
two-colored elastic closure
zweifarbiger Gummizugverschluss

Fabriqué en France, Bristol est un papier Clairefontaine extra-lisse et extra-blanc 100 % cellulose, idéal pour le dessin technique et la plume. Dans sa version 205 g/m², il accepte des charges d'encre plus importantes. Il supporte aussi les corrections répétées par grattage ou gommage sans pelucher. Fabriqué à base de colle végétale.

Made in France, Bristol is an extra smooth and extra white Clairefontaine paper 100% cellulose, ideal for technical drawing and pen. In its 205 gsm version, it accepts higher ink loads. It also supports repeated corrections by scratching or gumming without fluffing. Vegan friendly.

Das in Frankreich hergestellte Bristol ist ein extraglattes und extraweißes Clairefontaine-Papier aus 100 % Zellulose, das sich ideal für technische Zeichnungen und Federzeichnungen eignet. In seiner 205 g/m² Version nimmt es höhere Tintenlasten auf. Es widersteht auch wiederholten Korrekturen durch Kratzen oder Radieren, ohne zu fusseln. Hergestellt auf der Basis von pflanzlichem Klebstoff.





© dzarull_jeffry

Photos non contractuelles - Photos are not contractually binding - Bild vertraglich nicht bindend

RHODIA TOUCH

rhodia touch

Carb'on® Book

Carb'on® Book

Notizbuch Carb'on®



Papier Clairefontaine Carb'On® noir 120 g/m² fabriqué aux Pays-bas

- Brochure cousue rembourée rigide
- Couverture en simili cuir italien, fermeture à élastique
- Embossage logo Rhodia Touch au recto
- 112 pages non microperforées
- Ruban marque-page

55 lb Clairefontaine Carb'On® black paper made in the Netherlands

- Hardback book
- Italian leatherette hardcover, elastic closure
- Rhodia Touch logo embossed on front cover
- 56 non microperforated sheets
- Ribbon bookmark

Clairefontaine schwarzes Carb'On®-Papier 120 g/m² hergestellt in den Niederlanden

- Genähte Broschüre mit festem Einband
- Einband aus italienischem Kunstleder, Gummizugverschluss
- Rhodia Touch-Logoprägung auf der Vorderseite
- 56 nicht mikroperforierte Blätter
- Lesezeichenband

Format - Size	Uni - Blank - Blanko	MINI		
A5 paysage - landscape - Querformat	116116C	2	1	16
21 x 21	116117C	2	1	10
A4+ portrait - Hochformat	116118C	2	1	12

Filmé individuellement - Individually shrink-wrapped - Einzeln in Folie eingeschweißt



A5



21x21 cm



A4



PEFC® 10-31-714

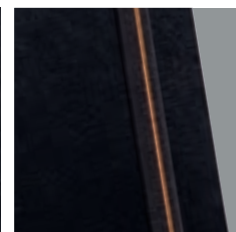
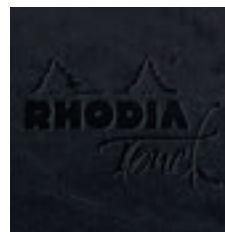

fermeture à élastique bicolore
two-colored elastic closure
Zweifarbiger Gummizugverschluss

Fabriqué par Schut aux Pays-Bas, Carb'On® est un papier Clairefontaine noir teinté dans la masse, très résistant à la lumière. Son grain fin lui permet de supporter les techniques sèches : dessin au crayon, feutre, craie, sanguine, pastel et marqueur pigmenté ; il se prête également aux rehauts à l'encre blanche ou à la gouache. Fabriqué à base de colle végétale.

Manufactured by Schut in the Netherlands, Carb'On® is a black Clairefontaine deep died paper, very resistant to light. Its fine grain allows it to withstand dry techniques: pencil, felt pen, chalk, red chalk, pastel and pigmented marker drawings; it is also suitable for highlights in white ink or gouache. Vegan friendly.

Carb'On® wird von Schut in den Niederlanden hergestellt und ist ein schwarzes, voll durchgefärbtes Clairefontaine-Papier mit hoher Lichtbeständigkeit. Dank seiner feinen Körnung eignet es sich für Trockentechniken: Bleistift-, Filzstift-, Kreide-, Rötel-, Pastell- und Pigmentmarkerzeichnungen; es eignet sich auch für das Übermalen mit weißer Tinte oder Gouache. Hergestellt auf der Basis von pflanzlichem Klebstoff.



rhodia touch

Calligrapher Pad

Calligrapher Pad

Block Calligrapher



Papier Clairefontaine Simili Japon naturel 130 g/m² fabriqué aux Pays-bas

- Bloc encollé entoilé en-tête
- Couverture enveloppante carte Maya noire 270 g/m²
- Embossage logo Rhodia Touch au recto
- 50 feuillets microperforés détachables

60 lb Clairefontaine natural Simili Japan paper made in the Netherlands

- Glued at the top, canvas-backed pad
- Maya black 126 lb card cover
- Rhodia Touch logo embossed on front cover
- 50 detachable microperforated sheets

Natürliches Clairefontaine-Papier Simili Japan 130 g/m², hergestellt in den Niederlanden

- Am Kopfende geklebter und gespannter Block
- Integraler Umschlag aus schwarzem Maya-Karton 270 g/m²
- Prägung Rhodia Touch-Logo auf der Vorderseite
- 50 mikroperforierte, abtrennbare Blätter

Format - Size	Uni - Blank - Blanko	MINI		
A5+ portrait - Hochformat	116122C	2	1	20
A4+ portrait - Hochformat	116123C	2	1	10



A5+

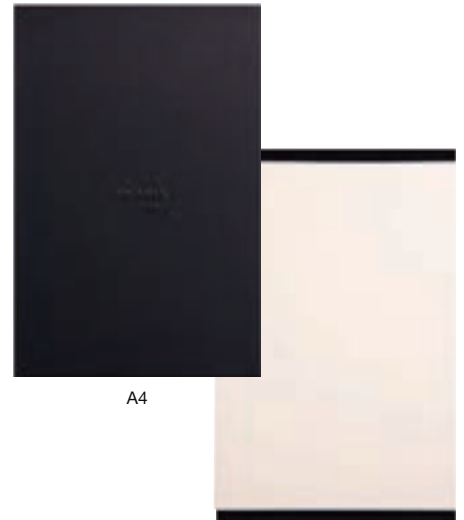

A4



Filmé individuellement - Individually shrink-wrapped - Einzeln in Folie eingeschweißt

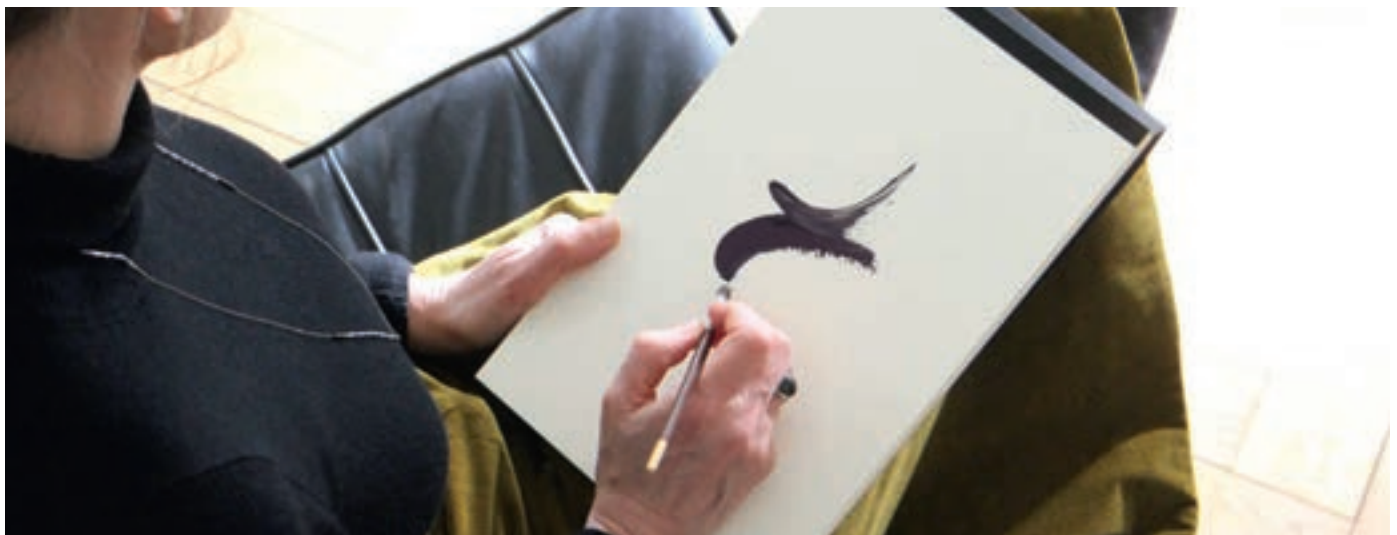

RHODIA TOUCH

Fabriqué par Schut aux Pays-Bas, le papier Simili Japon Clairefontaine 100 % pure cellulose ivoire a une belle teinte chaude et lumineuse. De par sa surface très fine et lisse, il est particulièrement adapté à l'impression des détails les plus fins. Grâce à son encollage interne et légèrement en surface, ce papier convient parfaitement pour la gravure en relief (taille d'épargne, linogravure) ou les techniques à plat comme la sérigraphie et le monotype. Il accroche bien l'encre et les détails. Dans sa version 130 g/m², il est adapté aux techniques d'épargne, de sérigraphie et de monotype, tandis que dans sa version 250 g/m², il est également parfait pour la taille douce. C'est une belle alternative aux papiers japonais. Le Simili Japon permet de garantir la pérennité des œuvres : sans acide, au pH neutre, avec une réserve alcaline pour résister au vieillissement. Fabriqué à base de colle végétale.

Made by Schut in the Netherlands, Clairefontaine's 100% pure cellulose ivory paper has a beautiful warm and luminous hue. Due to its very fine and smooth surface, it is particularly suitable for printing the finest details. Thanks to its internal sizing and slightly on the surface, this paper is perfectly suited for relief engraving (relief printing, linocut) or flat techniques such as screen printing and monotype. It holds ink and details well. In its 130 gsm version, it is suitable for relief, screen and monotype techniques, while in its 250 gsm version, it is also perfect for intaglio. It is a nice alternative to Japanese papers. The Simili Japon guarantees the durability of the works: acid-free, pH neutral, with an alkaline reserve to resist aging. Vegan friendly.

Das von Schut in den Niederlanden hergestellte Clairefontaine-Papier Simili Japan aus 100 % reiner elfenbeinfarbener Zellulose hat einen schönen, warmen und leuchtenden Farbton. Durch seine sehr feine und glatte Oberfläche eignet es sich besonders für den Druck von feinsten Details. Dank seiner inneren und leicht oberflächlichen Leimung eignet sich dieses Papier hervorragend für den Hochdruck (Kupferstich, Linolschnitt) oder für Flachdrucktechniken wie Siebdruck und Monotypie. Es nimmt Tinte und Details gut auf. In der Version 130 g/m² eignet es sich für Kupferstich-, Siebdruck- und Monotypietechniken, während es in der Version 250 g/m² auch hervorragend für den Tiefdruck geeignet ist. Es ist eine schöne Alternative zu Japanpapier. Das Papier Simili Japon ermöglicht es, die Langlebigkeit der Werke zu gewährleisten: säurefrei, pH-neutral und mit einer alkalischen Reserve, um der Alterung standzuhalten. Hergestellt auf der Basis von pflanzlichem Klebstoff.



rhodia touch

Calligrapher Book

Calligrapher Book

Notizbuch Calligrapher



Papier Clairefontaine Simili Japon naturel 250 g/m2
fabriqué en France

- Brochure cousue rembourée rigide
- Couverture en simili cuir italien, fermeture à élastique
- Embossage logo Rhodia Touch au recto
- 64 pages non microperforées
- Ruban marque-page

115 lb natural Clairefontaine Simili Japan paper
made in France

- Hardback artbook
- Italian leatherette hardcover, elastic closure
- Rhodia Touch logo embossed on front cover
- 32 non microperforated sheets
- Ribbon bookmark

*In Frankreich hergestelltes natürliches 250 g/m2
Clairefontaine-Papier Simili Japan.*

- *Genähte Broschüre mit festem Umschlag*
- *Umschlag aus italienischem Kunstleder, Gummizugverschluss*
- *Prägung Rhodia Touch-Logo auf der Vorderseite*
- *32 nicht mikroperforierte Bätter*
- *Lesezeichenband*

Format - Size - Format	Uni - Blank - Blanko	MINI		
A5 paysage - landscape - Querformat	116124C	2	1	32
A4 portrait / Hochformat	116125C	2	1	12

Filmé individuellement - Individually shrink-wrapped - Einzeln in Folie eingeschweißt



A5



A4

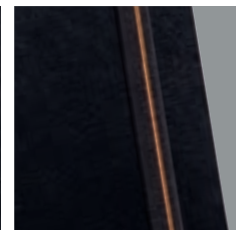
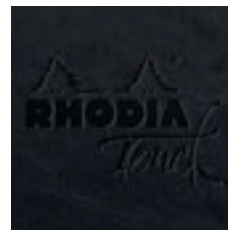
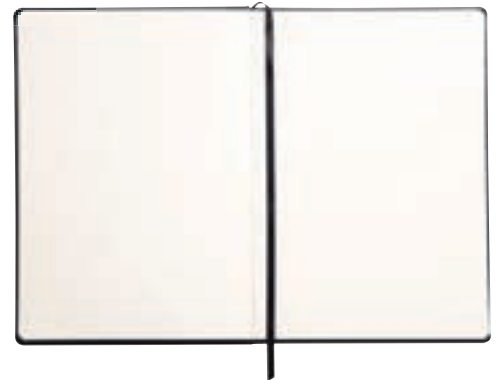

fermeture à élastique bicolore
two-colored elastic closure
zweifarbigiger Gummizugverschluss



RHODIA TOUCH

Fabriqué par Schut aux Pays-Bas, le papier Simili Japon Clairefontaine 100 % pure cellulose ivoire a une belle teinte chaude et lumineuse. De par sa surface très fine et lisse, il est particulièrement adapté à l'impression des détails les plus fins. Grâce à son encollage interne et légèrement en surface, ce papier convient parfaitement pour la gravure en relief (taille d'épargne, linogravure) ou les techniques à plat comme la sérigraphie et le monotype. Il accroche bien l'encre et les détails. Dans sa version 130 g/m², il est adapté aux techniques d'épargne, de sérigraphie et de monotype, tandis que dans sa version 250 g/m², il est également parfait pour la taille douce. C'est une belle alternative aux papiers japonais. Le Simili Japon permet de garantir la pérennité des œuvres : sans acide, au pH neutre, avec une réserve alcaline pour résister au vieillissement. Fabriqué à base de colle végétale.

Made by Schut in the Netherlands, Clairefontaine's 100% pure cellulose ivory paper has a beautiful warm and luminous hue. Due to its very fine and smooth surface, it is particularly suitable for printing the finest details. Thanks to its internal sizing and slightly on the surface, this paper is perfectly suited for relief engraving (relief printing, linocut) or flat techniques such as screen printing and monotype. It holds ink and details well. In its 130 gsm version, it is suitable for relief, screen and monotype techniques, while in its 250 gsm version, it is also perfect for intaglio. It is a nice alternative to Japanese papers. The Simili Japon guarantees the durability of the works: acid-free, pH neutral, with an alkaline reserve to resist aging. Vegan friendly.

Das von Schut in den Niederlanden hergestellte Clairefontaine-Papier Simili Japan aus 100 % reiner elfenbeinfarbener Zellulose hat einen schönen, warmen und leuchtenden Farbton. Durch seine sehr feine und glatte Oberfläche eignet es sich besonders für den Druck von feinsten Details. Dank seiner inneren und leicht oberflächlichen Leimung eignet sich dieses Papier hervorragend für den Hochdruck (Kupferstich, Linolschnitt) oder für Flachdrucktechniken wie Siebdruck und Monotypie. Es nimmt Tinte und Details gut auf. In der Version 130 g/m² eignet es sich für Kupferstich-, Siebdruck- und Monotypietechniken, während es in der Version 250 g/m² auch hervorragend für den Tiefdruck geeignet ist. Es ist eine schöne Alternative zu Japanpapier. Das Papier Simili Japan ermöglicht es, die Langlebigkeit der Werke zu gewährleisten: säurefrei, pH-neutral und mit einer alkalischen Reserve, um der Alterung standzuhalten. Hergestellt auf der Basis von pflanzlichem Klebstoff.



© emmanuelhenninger

rhodia touch

Pen & inkwash book



Papier Clairefontaine Lavis technique blanc 200 g/m² fabriqué aux Pays-bas

- Brochure cousue rembourée rigide
- Couverture en simili cuir italien, fermeture à élastique
- Embossage logo Rhodia Touch au recto
- 64 pages non microperforées
- Ruban marque-page

90 lb white Clairefontaine Pen & inkwash paper made in the Netherlands

- Hardback art book
- Italian leatherette hardcover, elastic closure
- Rhodia Touch logo embossed on front cover
- 32 non microperforated sheets
- Ribbon bookmark

Clairefontaine Weißes Lavis Technik-Papier 200 g/m² hergestellt in den Niederlanden

- Genähte Broschüre mit festem Umschlag
- Einband aus italienischem Kunstleder, Gummizugverschluss
- Rhodia Touch-Logoprägung auf der Vorderseite
- 32 nicht mikroperforierte Blätter
- Lesezeichenband

Format - Size	Uni - Blank - Blanko	MINI		
A5 paysage - landscape - Querformat	116126C	2	1	20
21 x 21	116127C	2	1	10
A4 portrait - Hochformat	116128C	2	1	14

Filmé individuellement - Individually shrink-wrapped - Einzeln in Folie eingeschweißt



A5



21 x 21 cm



A4

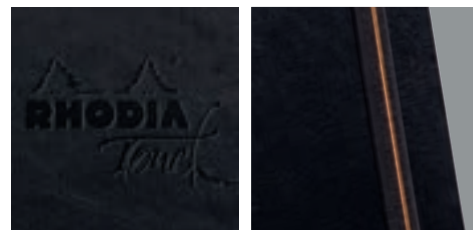
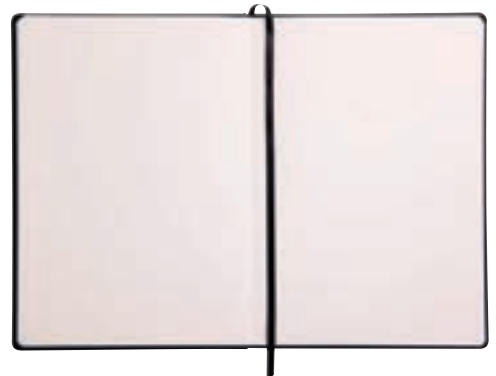

fermeture à élastique bicolore
two-colored elastic closure
zweifarbiger Gummizugverschluss

Fabriqué par Schut aux Pays-Bas, le Lavis technique Clairefontaine, d'une blancheur naturelle et à la surface quasi-lisse, accepte les tracés au crayon ou à la plume mais également les lavis à l'encre plus ou moins dilués et superposés. Fabriqué à base de colle végétale.

Made by Schut in the Netherlands, Clairefontaine 200 gsm Pen & inkwash paper, with its natural whiteness and almost smooth surface, can be used for pencil or pen tracings as well as ink washes, more or less diluted and layered. Vegan friendly.

Das von Schut in den Niederlanden hergestellte Clairefontaine Lavis Technik-Papier mit seinem natürlichen Weiß und seiner fast glatten Oberfläche eignet sich für Bleistift- und Federzeichnungen, aber auch für mehr oder weniger stark verdünnte und überlagerte Tintenwaschungen. Hergestellt auf der Basis von pflanzlichem Klebstoff.



rhodia touch

Étui rouleau 2 en 1



2-in-1 sleeve roll

2-in-1-Rollen-Etui

- Simili cuir italien, logo Rhodia Touch embossé
- Format ouvert : 23 x 32 cm
- Poche à outils compartimentée avec rabat de protection
- Contient une trousse amovible (attaches velcros) - format 22 x 7,5 cm
- Fermeture par lanière

- Italian leatherette, embossed Rhodia Touch logo
- Open size: 23 x 32 cm
- Compartmentalized tool pocket with protection flap
- Includes a removable flat case (with velcros fasteners) - format 22 x 7,5 cm
- Leatherette strap closure

- *Italienisches Kunstleder, Rhodia Touch geprägtes Logo*
- *Offenes Format: 23 x 32 cm*
- *Unterteilte Utensilientasche mit Abdecklasche.*
- *Enthält ein herausnehmbares Federmäppchen (Klettverschlüsse)*
- *Format 22 x 7,5 cm*
- *Riemenverschluss*

23 x 32	MINI		
noir - black - schwarz	116129C	2	1 24

Filmé individuellement - Individually shrink-wrapped
Einzeln in Folie eingeschweißt



logo Rhodia Touch embossé
embossed Rhodia Touch logo
Rhodia Touch geprägtes Logo



trousse amovible
removable flat case
herausnehmbares Federmäppchen

fermeture par lanière
leatherette strap closure
Riemenverschluss



Trousse 2 en 1 pour artiste

2-in-1 case for artists

2-in-1-Künstlermäppchen

- Toile noire imprimée, logo Rhodia Touch embossé
- Format ouvert : 45 x 30 cm
- Poche à outils compartimentée avec rabat de protection
- Contient une trousse amovible (attaches velcros) format 30 x 8 cm
- Fermeture par lanière

- Black printed fabric, embossed Rhodia Touch logo
- Open size: 45 x 30 cm
- Compartmentalized tool pocket with protection flap
- Includes a removable flat case (with velcros fasteners) format 30 x 8 cm
- strap closure

- Bedruckte schwarze Leinwand, geprägtes Rhodia Touch-Logo
- Format offen: 45 x 30 cm
- Unterteilte Utensilientasche mit Abdeckklappe.
- Enthält ein herausnehmbares Federmäppchen (Klettverschlüsse) Format 30 x 8 cm.
- Riemenverschluss

45x30		MINI	
noir - black - schwarz	116192C	2	1

Filmé individuellement - Individually shrink-wrapped
- Einzeln in Folie eingeschweißt



logo Rhodia Touch embossé
embossed Rhodia Touch logo
Rhodia Touch geprägtes Logo



fermeture par lanière
leatherette strap closure
Riemenverschluss

trousse amovible
removable flat case
herausnehmbares Federmäppchen



rhodia touch

CARTON À DESSIN

Art folder

Kunstmappe

- Simili cuir italien, logo Rhodia Touch embossé
- 3 rabats
- Fermeture par élastique

- Italian leatherette, embossed Rhodia Touch logo
- 3 flaps
- elastic closure

- *Italienisches Kunstleder, geprägtes Rhodia Touch-Logo*
- *3 Klappen*
- *Gummizugverschluss*

		MINI	
32x45	116193C	2	1
52x72	116194C	2	1

Filmé individuellement - Individually shrink-wrapped - Einzeln in Folie eingeschweißt

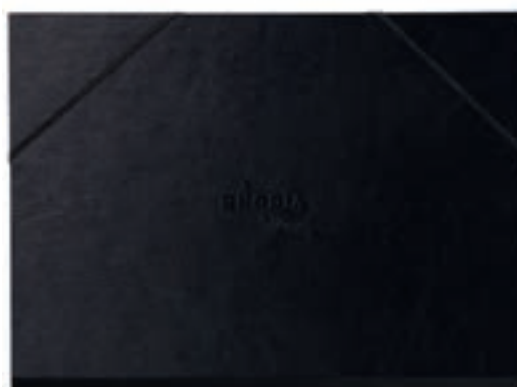
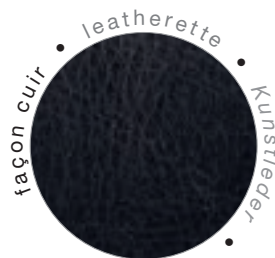

32x45



52x72





rhodia touch

PLV et affiche

POS advertising and poster

POS-Werbung und Poster



15,5 x 20 x 15,5		
présentoir + nuancier + 50 dépliantes display + swatch book + 50 leaflets Display + Musterbuch + 50 Prospekte	116132C	1
recharge 50 dépliantes 50 leaflets refill Nachfüllpack 50 Prospekte	116131C	50
nuancier papiers Touch paper swatch book Papier-Musterbuch	RCDIVERS36	1

affiche / poster 40 x 60	français French französisch	anglais English englisch	
Rhodia Touch - Watercolor book	250079C NEW	250080C NEW	1
Rhodia Touch - Mixed media book	250081C NEW	250082C NEW	1



affiche / poster 40 x 60	français French françaisch	anglais English englisch	🏠
Rhodia Touch - Black Maya Pad	250053C	250054C	1
Rhodia Touch - Pen & Inkwash book 1	250055C	250056C	1
Rhodia Touch - Pen & Inkwash book 2	250057C	250058C	1
Rhodia Touch - Grey Maya Pad	250059C	250060C	1
Rhodia Touch - Bristol book 1	250061C	250062C	1
Rhodia Touch - Bristol book 2	250063C	250064C	1
Rhodia Touch - Bristol book 3	250065C	250066C	1
Rhodia Touch - Pen & Inkwash book 3	250067C	250068C	1
Rhodia Touch - Pen & Inkwash book 4	250069C	250070C	1
Rhodia Touch - Pen & Inkwash book 5	250071C	250072C	1

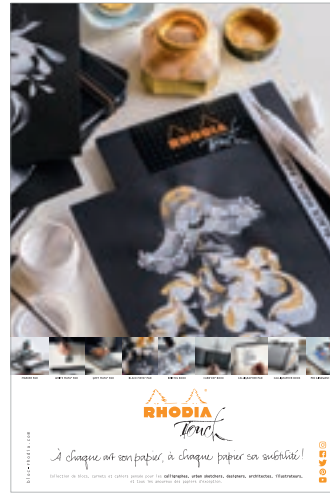

FR - 250053C
GB - 250054C

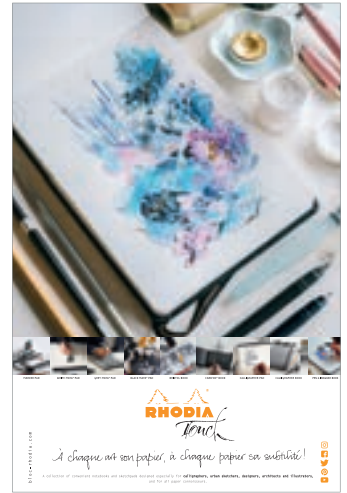

FR - 250055C
GB - 250056C

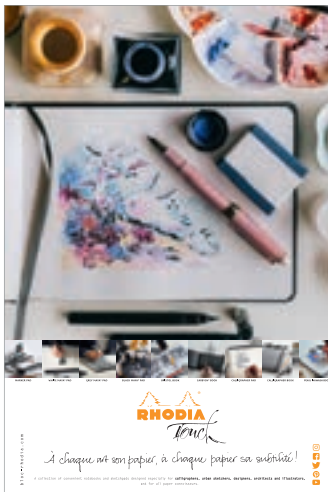

FR - 250057C
GB - 250058C

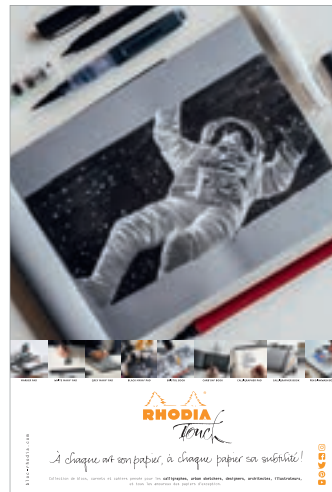

FR - 250059C
GB - 250060C

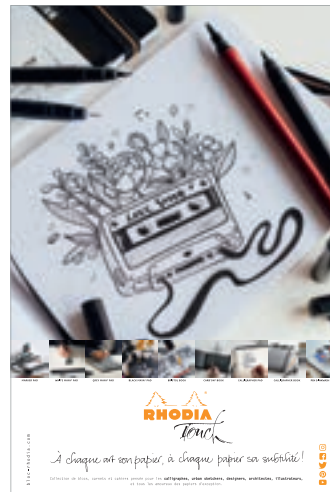

FR - 250061C
GB - 250062C



FR - 250063C
GB - 250064C

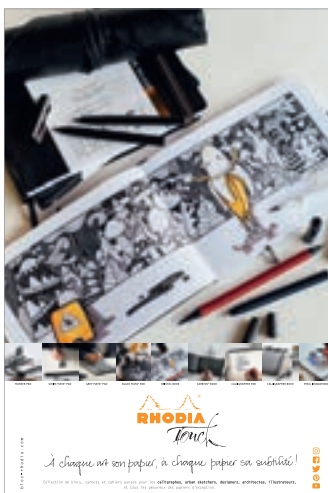

FR - 250065C
GB - 250066C

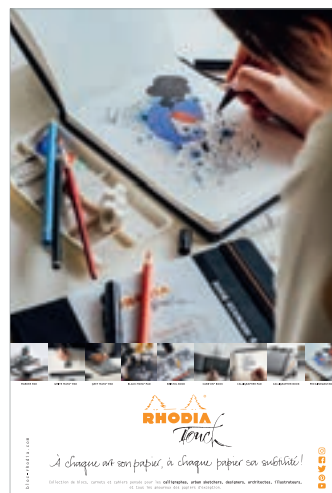

FR - 250067C
GB - 250068C

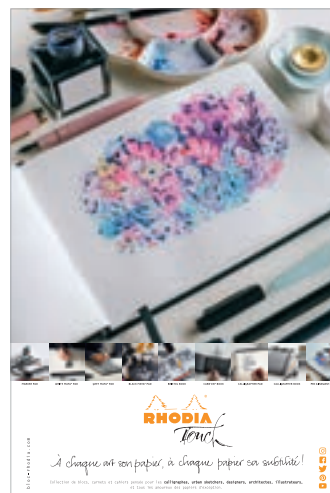

FR - 250069C
GB - 250070C

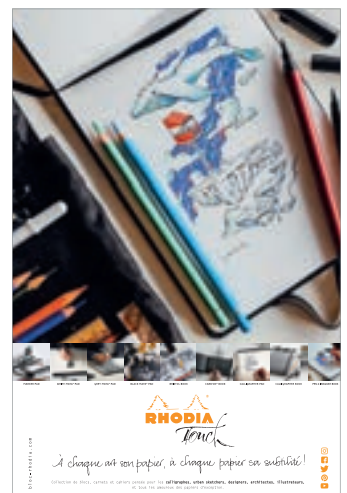

FR - 250071C
GB - 250072C

rhodia x PAScribe



CO-BRANDING

Beautiful writing comes more easily on paper which helps you to express yourself. I specifically chose these Clairefontaine papers because of how the nibs and inks interacted with them. It was such a joyful experience, I was compelled to share it with you. I wanted you to feel what I felt when the nib, the ink and the paper worked together. Apart from it being a physical experience, this interaction of three things is very much like a spirit-mind-body interaction/conjunction. Breathe, take your time to write, touch the lines top and bottom. Let the writing be a meditation. Send someone a stunning letter in light ink on dark paper. Share the magic.

PA Scribe

« Bien pratiquer la calligraphie est plus facile sur un papier qui vous aide à vous exprimer. J'ai choisi ces papiers Clairefontaine pour la façon dont les plumes et les encres interagissent avec eux. Ce fut une expérience si joyeuse que je me devais de la partager avec vous. Je voulais que vous ressentiez ce que j'ai ressenti quand la plume, l'encre et le papier travaillent ensemble. En plus d'être une expérience physique, cette interaction ressemble beaucoup à celle qui existe entre le corps et l'esprit. Respirez, prenez le temps d'écrire, touchez les lignes, en haut et en bas, que l'écriture soit une méditation. Envoyez à quelqu'un une lettre remarquable à l'encre claire sur papier foncé. Partagez la magie. »

« Das richtige Üben der Kalligraphie ist am einfachsten auf einem Papier, das Ihnen volle Ausdruckskraft verleiht. Ich habe diese Clairefontaine-Papiere aufgrund der Art und Weise ausgewählt, wie die Federn und Tinten mit ihnen interagieren. Dies war eine so wundervolle Erfahrung, dass ich sie unbedingt mit Ihnen teilen musste. Ich möchte, dass Sie spüren, wie ich mich gefühlt habe, als Feder, Tinte und Papier zusammenwirkten. Dieses Zusammenspiel ist nicht nur eine körperliche Erfahrung, sondern ähnelt auch sehr der Wechselwirkung zwischen Körper und Geist. Atmen Sie durch, nehmen Sie sich Zeit zum Schreiben, berühren Sie die Zeilen, nach oben und nach unten, lassen Sie das Schreiben zur Meditation werden. Schicken Sie jemandem einen bemerkenswerten Brief mit heller Tinte auf dunklem Papier. Teilen Sie die Magie. »

PAScribe bloc de pratique de la calligraphie et de correspondance

PAScribe Carb'On® Pad

Block PAScribe Carb'On®

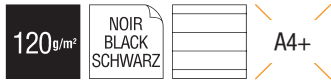

- Papier Clairefontaine Carb'On® noir 120 g/m² fabriqué aux Pays-bas
- Bloc agrafé en-tête. Sole cartonnée
 - Couverture enveloppante rainée carte Maya noire 270 g/m²
 - 60 feuillets microperforés détachables
 - Réglure horizontale noire lignée 6 mm recto/verso
 - Épaisseur de ligne 0,5 pt

- 55 lb Clairefontaine Carb'On® black paper made in the Netherlands
- Head stapled notepad. Stiff back cover
 - Maya black 126 lb scored cover
 - 60 detachable microperforated sheets
 - Horizontal 6 mm black lined ruling on both sides
 - Line thickness 0,5 pt

- Clairefontaine schwarzes Carb'On®-Papier 120 g/m², hergestellt in den Niederlanden
- Am Kopfende gehefteter Block. Kartonierte Sohle
 - Gerillter Einband mit schwarzem Maya-Karton 270 g/m²
 - 60 mikroperforierte, abtrennbare Blätter
 - Horizontale Linierung schwarz liniert 6 mm Vorder- und Rückseite
 - Linienstärke 0,5 pt

Format - Size	Ligné - Liniert 6 mm	MINI		
A4+ portrait - Hochformat	19005C	1	1	20

Filmé individuellement - Individually shrink-wrapped - Einzeln in Folie eingeschweißt



Fondée par le célèbre calligraphe Paul Antonio, PAScribe est la marque dédiée aux médias sociaux de son studio Paul Antonio Scribe. C'est aussi le support privilégié des outils et matériels utilisés par Paul dans son atelier et lors de ses voyages. Paul a reçu une formation de scribe, de doreur et d'artiste héraldique. Il a ensuite étudié l'illustration archéologique avec une spécialisation en systèmes d'écritures anciennes. Ses hiéroglyphes égyptiens illustrés sont conservés au Metropolitan Museum, NYC.

PAScribe was founded by Paul Antonio as the social media brand for Paul Antonio Scribe. It is also the arm of tools and materials used by Paul in his studio and on his travels. Paul trained as Scribe, Gilder and Heraldic Artist. He went on to study Archaeological Illustration with a specialism in Ancient Writing Systems. His illustrated Egyptian hieroglyphs are housed in the Metropolitan Museum, NYC.

PAScribe wurde von dem berühmten Kalligrafen Paul Antonio gegründet und ist die spezielle Marke für soziale Medien seines Studios Paul Antonio Scribe. Sie ist außerdem das bevorzugte Medium für die Arbeitsgeräte und Materialien, die Paul in seinem Atelier und auf seinen Reisen verwendet. Paul wurde als Scribe, Vergolder und Heraldikkünstler ausgebildet. Anschließend studierte er archäologische Illustration mit einer Spezialisierung auf antike Schriftsysteme. Seine illustrierten ägyptischen Hieroglyphen werden im Metropolitan Museum, NYC, aufbewahrt.



Le papier noir Carb'On® 120 g/m² teinté dans la masse, d'un noir très profond, est idéal pour les travaux en contraste. Ce papier au double grain se prête parfaitement bien à la calligraphie, que ce soit sur le recto lisse ou le verso au grain très fin. Sa porosité, parfaite pour accueillir toutes les encres, permet également leur séchage rapide. Sans acide au pH neutre, il est résistant à la lumière. Fabriqué à base de colle végétale.

This Carb'On® black 55 lb deep dyed paper with its strong dark shade is perfect for contrast works. This double-surface paper is ideal for calligraphy, whether on the smooth front or the very fine-grained back side. Its porosity, perfect for all inks, also allows fast drying. Acid free with pH neutral. Vegan friendly.

Das voll durchgefärbte, schwarze Carb'On®-Papier 120 g/m² ist ideal für Kontrastarbeiten. Dieses Papier mit doppelter Körnung eignet sich hervorragend für Kalligrafie, sowohl auf der glatten Vorderseite als auch auf der feinkörnigen Rückseite. Seine Porosität ist perfekt für die Aufnahme aller Tinten und ermöglicht auch deren schnelles Trocknen. Das säurefreie und pH-neutrale Material ist lichtbeständig. Hergestellt auf der Basis von pflanzlichem Klebstoff.



© PAScribe

Calligraphy practice & correspondence pad

PAScribe Grey Maya® Pad

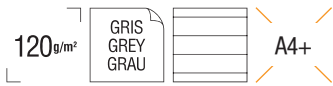

- Papier Clairefontaine Maya® gris lisse 120 g/m² fabriqué en France
- Bloc agrafé en-tête. Sole cartonnée
- Couverture enveloppante rainée carte Maya grise 270 g/m²
- 60 feuillets microperforés détachables
- Réglure horizontale grise lignée 6 mm recto/verso
- Épaisseur de ligne 0,1 pt

- 55 lb Clairefontaine smooth grey Maya® paper made in France
- Head stapled notepad. Stiff back cover
- Maya grey 126 lb scored cover
- 60 detachable microperforated sheets
- Horizontal 6 mm grey lined ruling on both sides
- Line thickness 0,1 pt

Clairefontaine graues glattes Maya®-Papier 120 g/m² hergestellt in Frankreich

- Am Kopfende gehefteter Block. Kartonierte Sohle
- Gerillter Einband aus grauem Maya-Karton 270 g/m²
- 60 mikroperforierte, abtrennbare Blätter
- Horizontale Linierung grau liniert 6 mm Vorder- und Rückseite
- Liniestärke 0,1 pt.

Format - Size	Ligné - Liniert 6 mm	MINI		
A4+ portrait - Hochformat	19006C	1	1	20

Filmé individuellement - Individually shrink-wrapped - Einzeln in Folie eingeschweißt

Paul est également scribe au bureau de la Couronne au Royaume-Uni, écrivant certaines des lois du pays. Paul travaille dans des formes calligraphiques traditionnelles ou contemporaines, pour des commandes, et il voyage à l'étranger pour enseigner son art.

Paul is also a Crown Office Scribe for the UK handwriting some of the country's laws. Paul works in both traditional and contemporary calligraphic forms for commissions, and he travels internationally teaching his craft.

Paul ist außerdem Schriftführer im britischen Kronbüro und schreibt einige der Gesetze des Landes. Paul arbeitet in traditionellen und zeitgenössischen kalligrafischen Formen, für Aufträge, und er reist ins Ausland, um seine Kunst zu lehren.



Le papier Maya® gris lisse 120 g/m² teinté dans la masse est fait à base de cellulose. Parfaitement lisse sur les deux faces, il se prête particulièrement bien à la calligraphie, sa surface permettant un séchage rapide de l'encre. Sans acide, au pH neutre. Fabriqué à base de colle végétale.

This 55 lb smooth grey Maya® paper is a deep dyed paper made of cellulose. Perfectly smooth on both sides, it is particularly suitable for calligraphy, its surface allowing also quick drying of the ink. Acid free with pH neutral. Vegan friendly.

Das glatte graue Maya®-Papier 120 g/m² ist voll durchgefärbt und wird auf Zellulosebasis hergestellt. Es ist auf beiden Seiten vollkommen glatt und eignet sich besonders gut für die Kalligrafie, da seine Oberfläche ein schnelles Trocknen der Tinte ermöglicht. Säurefrei und pH-neutral. Hergestellt auf der Basis von pflanzlichem Klebstoff.



© PAScribe

Photos non contractuelles - Photos are not contractually binding - Bild vertraglich nicht bindend

CO-BRANDING

collection Orange botanique



CO-BRANDING



Nouveau

Des fleurs, des textures, une touche d'orange - découvrez Orange Botanique !

Toutes les collections Rhodia cultivent révérencieusement l'histoire et les valeurs d'une marque héritage, qui n'en néglige pas pour autant de respirer l'air du temps, d'être à l'écoute des tendances ou de se nourrir des divers courants de la création contemporaine. Pour Rhodia, s'inspirer plus singulièrement du regard et du talent des jeunes créateurs, c'est enrichir la tradition tout en pariant sur l'avenir.

Avec Orange Botanique, la marque célèbre sur papier le mariage des textures et des motifs des tissus chers à la styliste alsacienne Elisa Walter, dans une farandole d'articles de papeterie tout en fleurs et toucher textile. Son œil de designer et sa patte d'illustratrice subliment cette collection et lui instillent ce petit supplément de grâce qu'offrent les bouquets précieux que l'on compose soi-même.

New

Flowers, textures, a hint of orange - discover Orange Botanique !

Every Rhodia collection reverently upholds the history and values of a heritage brand, while always remaining highly contemporary, aware of the latest trends and drawing on various spheres of contemporary creation. For Rhodia, being inspired by the eye and talent of young designers means enriching tradition while focusing on the future.

With Orange Botanique, the brand celebrates the marriage of the fabric textures and patterns beloved by Alsace-born stylist Elisa Walter on paper, through an array of floral stationery items with a textile feel. Her eye for design and flair for illustration enhance this collection, suffusing it with that little added charm that comes with the gift of a special hand-tied posy.

Neu

Blumen, Texturen, ein Hauch von Orange - entdecken Sie Orange Botanique!

Alle Rhodia-Kollektionen zeichnen sich durch die Geschichte und die Werte einer Traditionsmarke aus, ohne dabei den Zeitgeist zu vernachlässigen, Trends zu verfolgen oder sich von den verschiedenen Strömungen der zeitgenössischen Kreation inspirieren zu lassen.

Für Rhodia bedeutet die Inspiration durch das Auge und das Talent junger Designer, die Tradition zu bereichern und gleichzeitig auf die Zukunft zu setzen.

Mit Orange Botanique zelebriert die Marke die Verbindung von Texturen und Stoffmustern, die der elsässischen Designerin Elisa Walter am Herzen liegt, auf Papier in einer ganzen Fülle von Schreibwaren, die ganz aus Blumen und textiler Haptik bestehen. Ihr Auge als Designerin und ihre Fingerfertigkeit als Illustratorin veredeln diese Kollektion und verleihen ihr das gewisse Extra an Schönheit, das selbst zusammengestellte, kostbare Sträuße bieten.

collection Orange botanique



- ① **Bloc entoilé** / canvas-backed pad / *Kopfende gespannter Block*
- ② **Goalbook souple** / Softcover Goalbook / *Goalbook mit flexiblem Umschlag*
- ③ **Carnet à reliure intégrale cachée**
Hidden wirebound book / *Notizbuch mit versteckter Doppelspiralbindung*
- ④ **Carnet piqûre textile** / Sewn spine notebook / *Notizbuch mit Textilheftung*
- ⑤ **Carnet souple** / Softcover notebook / *Notizbuch mit flexiblem Umschlag*
- ⑥ **Carnet rembordé rigide** / Hardcover notebook / *Notizbuch mit festem Umschlag*
- ⑦ **Trousse** / Pencil case / *Federmäppchen*

NEW



- ⑧ **Support de téléphone** / Mobile phone stand / *Telefonständer*
- ⑨ **Chemise à élastiques** / Elasticated folder / *Mappe mit Gummizug*
- ⑩ **Classeur à levier** / Level arch file / *Hebelordner*
- ⑪ **Pot à crayons** / Pencil holder / *Stiftebox*
- ⑫ **Porte-courrier** / Letter holder / *Briefständer*
- ⑬ **Porte-revues** / Magazine rack / *Zeitschriftenständer*
- ⑭ **Sous-main rigide** / Hardback desk pad / *Feste Schreibtischunterlage*

collection Orange botanique

1 Bloc entoilé

Canvas-backed pad

Kopfende gespannter Block

120031C  - 1

A5 ligné, 70 feuillets microperforés, couverture pelliculée soft touch

A5 lined, 70 microperforated sheets, soft touch cover

A5 liniert, 70 mikroperforierte Blätter, laminiertes Soft-Touch-Umschlag

Intérieur / Inside / Innen



1

Papier ivoire / Ivory paper / Elfenbein Papier



Intérieur / Inside / Innen

2



2 Goalbook souple

Softcover Goalbook

Goalbook mit flexiblem Umschlag

120035C  - 1

A5 dot, 240 pages, simili cuir

A5 dot, 120 sheets, leatherette

A5 dot, 120 Blätt, Kunstleder

3 Carnet à reliure intégrale cachée

Hidden wirebound book

Notizbuch mit versteckter Doppelspiralbindung

120032C  - 1

A5 ligné, 120 pages, couverture pelliculée soft touch

A5 lined, 60 sheets, soft touch cover

A5 liniert, 60 Blätt, Soft-Touch-Umschlag

Intérieur / Inside / Innen



3

Dos / Back / Umschlagrücken



Intérieur / Inside / Innen



4



4 Carnet piqûre textile

Sewn spine notebook

Notizbuch mit Textilheftung

120027C 7,5x12 - 48 pages/24 sheets/24 Blatt - 1

120028C 9x14 - 64 pages/32 sheets/32 Blatt - 1

120029C 11x17 - 64 pages/32 sheets/32 Blatt - 1

120030C A5 - 64 pages/32 sheets/32 Blatt - 1

Carnets lignés, couverture pelliculée soft touch

Lined notebooks, soft touch cover

Linierte Notizbücher, Soft-Touch-Umschlag

5 Carnet souple

Softcover notebook

Notizbuch mit flexiblem Umschlag

120034C - 1

A5 ligné, 160 pages, simili cuir

A5 lined, 80 sheets, leatherette

A5 liniert, 80 Blätter, Kunstleder

6 Carnet rembordé rigide

Hardcover notebook

Notizbuch mit festem Umschlag

120033C - 1

A5 ligné, 192 pages, simili cuir

A5 lined, 96 sheets, leatherette

A5 liniert, 96 Blätter, Kunstleder

Intérieur / Inside / Innen

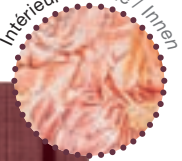

Intérieur / Inside / Innen

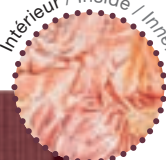

5

6



collection Orange botanique



7 Trousse

Pencil case

Federmäppchen

120041C - 1

20 x 5 x 2,5 cm, simili cuir,
intérieur coton imprimé

20 x 5 x 2,5 cm, leatherette,
printed cotton inside

20 x 5 x 2,5 cm, Kunstleder,
innen bedruckte Baumwolle



7

8 Support de téléphone

Mobile phone stand

Telefonständer

120040C - 1

8 x 8,5 x 13 cm, recto en simili cuir, verso imprimé

8 x 8,5 x 13 cm, leatherette, printed back

8 x 8,5 x 13 cm, Kunstleder, bedruckte Rückseite

Verso / back / Rückseite



8



Intérieur / Inside / Innen



9

9 Chemise à élastiques

Elasticated folder

Mappe mit Gummizug

120026C - 1

24 x 32 cm, 3 rabats, carte pelliculée soft touch

24 x 32 cm, 3 flaps, soft touch cover

24 x 32 cm, 3 Klappen, Soft-Touch-Umschlag

Intérieur / Inside / Innen



10

10 Classeur à levier

Level arch file

Hebelordner

120025C - 1

A4 - 21 x 29,7 cm, dos 7 cm, pelliculage mat, intérieur imprimé

A4 - 21 x 29,7 cm, 7 cm spine, mat lamination, printed inside

A4 - 21 x 29,7 cm, Rücken 7 cm, matte Laminierung, innen bedruckt

11 Pot à crayons

Pencil holder
Stiftebox

120036C  - 1

8 x 8 x 11 cm, 4 compartiments, simili cuir, intérieur imprimé

8 x 8 x 11 cm, 4 compartiments, leatherette, printed inside

8 x 8 x 11 cm, 4 Fächer, Kunstleder, innen bedruckt

12 Porte-courrier

Letter holder
Briefständer

120037C  - 1

25 x 10 x 14 cm, 2 compartiments, simili cuir, intérieur imprimé

25 x 10 x 14 cm, 2 compartiments, leatherette, printed inside

25 x 10 x 14 cm, 2 Fächer, Kunstleder, innen bedruckt

13 Porte-revues

Magazine rack
Zeitschriftenständer

120038C  - 1

10 x 25 x 31 cm, simili cuir, intérieur imprimé, porte-étiquette en métal brossé

10 x 25 x 31 cm, leatherette, printed inside, metallic label holder

10 x 25 x 31 cm, Kunstleder, innen bedruckt, Metall-Etikettenhalter

14 Sous-main rigide

Hardback desk pad
Feste Schreibtischunterlage

120039C  - 1

60 x 40 cm, simili cuir

60 x 40 cm, leatherette

60 x 40 cm, Kunstleder

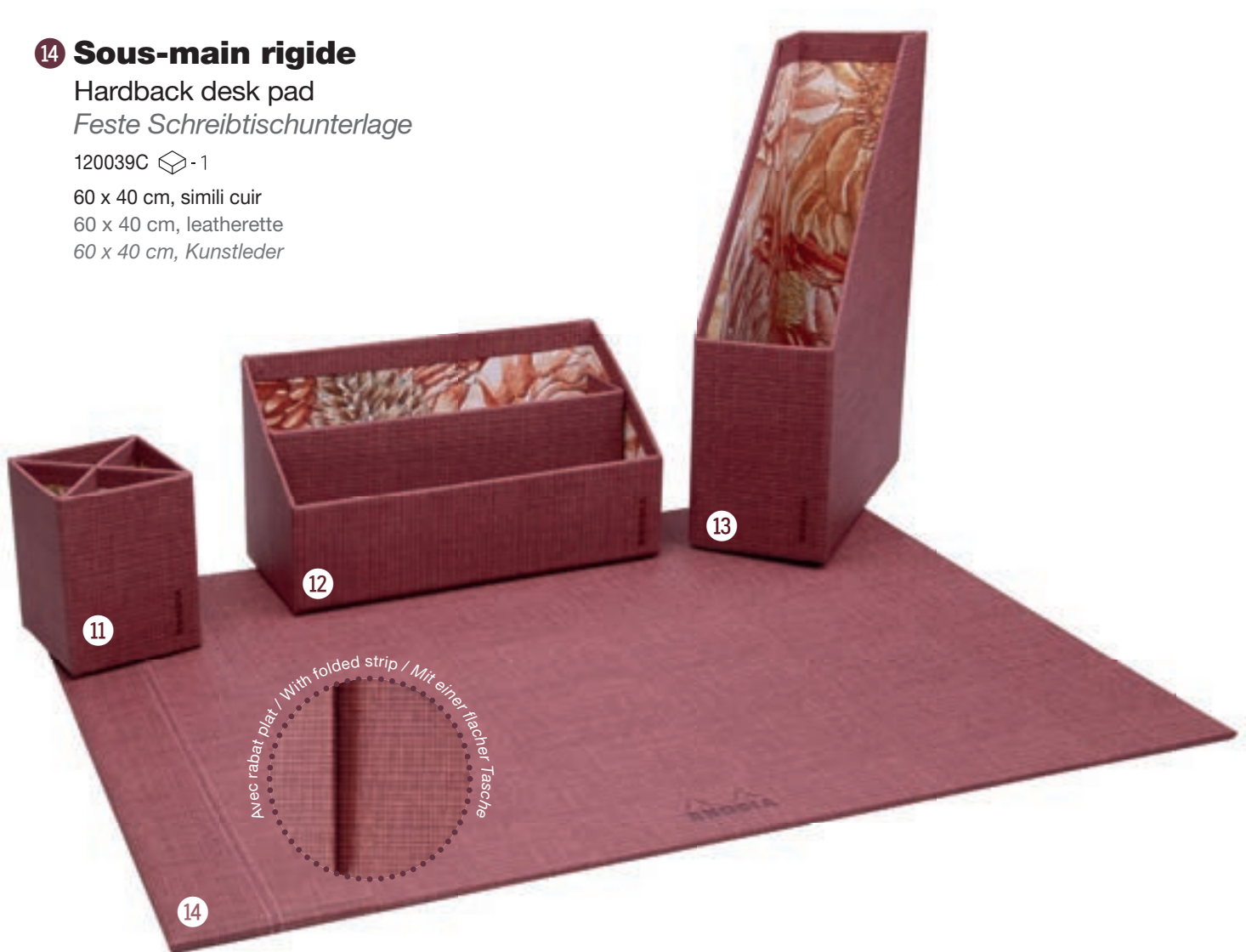



Merchandising Mobilier Rhodia dans le monde

Merchandising - POS furniture - Rhodia in the world
Merchandising - POS-Möbel - Rhodia in der Welt



PLV & merchandising

matériel publicitaire - publicity support

Vitrophanie Rhodia

Rhodia window sticker
Rhodia-Fensteraufkleber

Ø 20 cm			
Rhodia	40152C		1



Pin's Rhodia

2,6 x 2 cm			
logo noir - black logo - schwarzes Logo	240006C		5



PLV chevalet carton

POS cardboard frame
POS-Kartonstaffelei

17 x 24 cm	paysage - landscape - Querformat		
nous consulter - consult us Bitte kontaktieren Sie uns	232000C		1



Rappel de marque plexiglas

POS plexiglass cube
POS-Plexiglaswürfel

21 x 3 x 12 cm			
nous consulter - consult us - Bitte kontaktieren Sie uns	230000C		1



Polo Rhodia

Rhodia polo shirt
Rhodia polo shirt



NOIR
BLACK
SCHWARZ

Logo Rhodia orange brodé (devant et dos)
Embroidered Rhodia logo (front and back)
Gesticktes orangefarbenes Rhodia-Logo (Vorder- und Rückseite)

	M	L	XL	
femme - woman - Damen	240003C	240004C	240005C	1
homme - man - Herren	240000C	240001C	240002C	1



Bloc factice

Dummy notepad
Dummy-Block

Forex® sérigraphié, structure métallique
Printed Forex®, metallic structure
Forex® mit Siebdruck, Metallstruktur

40,5 x 57 x 6,5 cm			
nous consulter - consult us - Bitte kontaktieren Sie uns	230001C		1

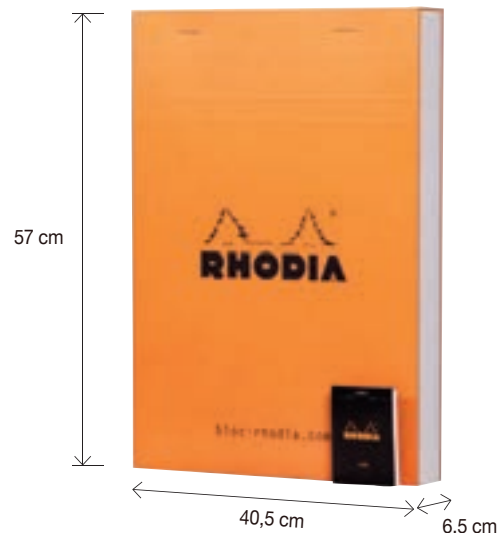

Sac publicitaire papier brillant

Glossy promotional paper bag

Werbetasche aus Glanzpapier

35 x 34 x 14 cm



blanc - white - weiß

200003C NEW

5



verso

recto

Photos non contractuelles - Photos are not contractually binding - Bild vertraglich nicht bindend

PLV Rhodia Touch

POS Rhodia Touch

POS Rhodia Touch

15,5 x 20 x 15,5 cm



présentoir + nuancier + 50 dépliantes
display + swatch book + 50 leaflets - Display +
Musterbuch + 50 Prospekte

116132C

1

recharge 50 dépliantes

116131C

50

50 leaflets refill - Nachfüllpack 50 Prospekte

nuancier papiers Touch

RCDIVERS36

1

paper swatch book - Papier-Musterbuch

Voir le détail en p.238 - See details on p.238 - Siehe Einzelheiten auf S. 238



PLV Rhodiarama

POS Rhodiarama

POS Rhodiarama

15,5 x 20 x 15,5 cm



présentoir Rhodiarama + 50 dépliantes
display + 50 leaflets - Display + 50 Prospekte

116134C

1

recharge 50 dépliantes Rhodiarama

116135C

50

50 leaflets refill + Nachfüllpack 50 Prospekte

Voir le détail en p.168 - See details on p.168 - Siehe Einzelheiten auf S. 168



Nuancier Rhodiarama

Swatch book Rhodiarama

Musterbuch Rhodiarama

A5 - 14,8 x 21 cm



nuancier triptyque Rhodiarama

999939C

1

Rhodiarama swatch book - Rhodiarama-Musterbuch

Voir le détail en p.170 - See details on p.170 - Siehe Einzelheiten auf S. 170



A5



PLV & merchandising

affiches & kakemono - posters

40 x 60 cm	français French französisch	anglais English englisch	📦
bloc 2.0 - 2.0 pad	250000C	250001C	1
extraordinaire	250038C		1
journée - day - Tag	250006C	250007C	1
électricité	250020C	250050C	1
visionnaire	250039C	250040C	1
scRipt	250036C	250037C	1
60 x 200 cm	ilingue - bilingual - zweis- prachig		📦
kakemono	250019C		1

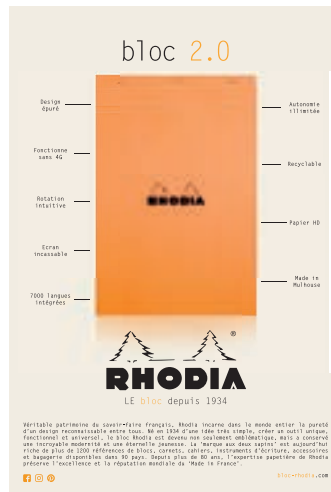

FR - 250000C
GB - 250001C



250038C

Véritable patrimoine du savoir-faire français, Rhodia incarne dans le monde entier la pureté d'un design reconnaissable entre tous. Né en 1934 d'une idée très simple, créer un outil unique, fonctionnel et universel, le bloc agrafé Rhodia est devenu non seulement emblématique, mais a conservé une incroyable modernité et une éternelle jeunesse. La « marque aux deux sapins » est aujourd'hui riche de plus de 1600 références de blocs, carnets, cahiers, agendas, instruments d'écriture et accessoires disponibles dans plus de 90 pays. Année après année, le savoir-faire papetier de Rhodia préserve l'excellence et la réputation mondiale du « Made in France ».

As a real cultural heritage of French know-how, the Rhodia brand embodies in the world at large a pure design which stands out against all others. Born in 1934 from a very simple idea - to create a unique, functional and universal tool, the Rhodia stapled notepad became not only iconic, but still has a modern look and eternal youth. Today "the brand with two fir trees" offers more than 1600 references of notepads, notebooks, diaries, writing instruments and accessories in more than 90 countries. Year after year, the expertise of Rhodia preserves the excellence and worldwide reputation of the "Made in France" statement.

📦 blocs, carnets, cahiers, agendas, instruments d'écriture et accessoires
notepads, notebooks, diaries, writing instruments and accessories

bloc-rhodia.com

250019C



FR - 250006C
GB - 250007C



FR - 250020C
GB - 250050C



FR - 250039C
GB - 250040C



FR - 250036C
GB - 250037C

40 x 60 cm	français	anglais	📦
	French françaisch	English englisch	
Rhodia scRipt OR	250075C NEW	250076C NEW	1
Rhodia scRipt gamme	250083C NEW	250084C NEW	1
Rhodia Touch - Watercolor book	250079C NEW	250080C NEW	1
Rhodia Touch - Mixed media book	250081C NEW	250082C NEW	1
Rhodiactive Greenbook	250077C NEW	250078C NEW	1
Rhodiactive Agenda Webplanner	250083C NEW	250084C NEW	1
Rhodiarama Goalbook	250045C	250046C	1
Goûts et couleurs-Feed your creativity - Nähren Sie Ihre Kreativität	250051C	250052C	1
La vie est plus belle - Life is beautiful - Das Leben ist wunderbar!	250047C	250048C	1
Unlimited	250017C		1
Rhodiarama hardcover	250008C	250009C	1



FR - 250075C
GB - 250076C

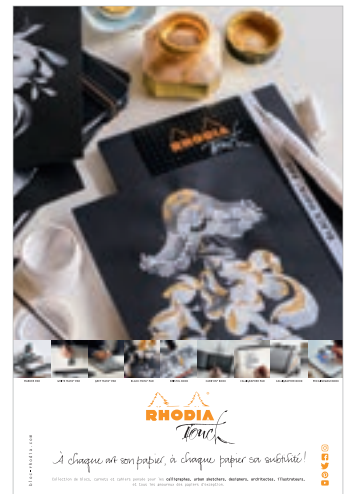

FR - 250053C
GB - 250054C

Autres modèles disponibles p. 238
Other designs available p. 238
Andere Modelle erhältlich S. 238



FR - 250077C
GB - 250078C



FR - 250045C
GB - 250046C



FR - 250051C
GB - 250052C



FR - 250047C
GB - 250048C



FR - 250083C
GB - 250084C

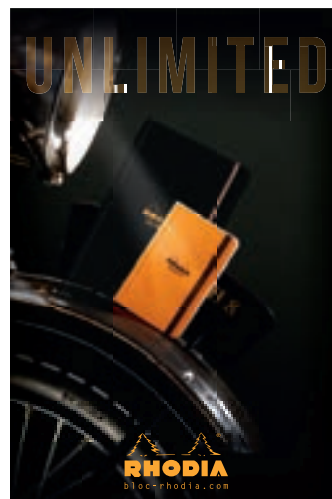

250017C



FR - 250008C
GB - 250009C



FR - 250033C
GB - 250034C

Photos non contractuelles - Photos are not contractually binding - Bild vertraglich nicht bindend

PLY-MERCHANDISING

PLV & merchandising

displays

Présentoir carton Basics

Basics cardboard display

Kartondisplay Basics

35 x 46 x 20 cm



195 produits - products - Produkte

200099PC

1



Plexi petit modèle

Plexiglass display - small

Plexiglass-Display - klein

35,5 x 32,5 x 29 cm



nous consulter - consult us - Bitte kontaktieren Sie uns

210000PC

1



Présentoir N°10

N°10 display

Display Nr. 10

Boîte présentoir en carton «prête-à-vendre» sélection de 60 blocs Orange & Black

Ready-to-sell cardboard box of 60 selected Orange & Black notepads

«verkaufsfertige» Display-Kartonbox mit einer Auswahl von 60 Blöcken Orange & Black

17 x 20 x 25 cm

5/5

L



60 assortis - assorted - assortiert

100002PC

100006PC

60



Plexi moyen modèle

Plexiglass display - medium

Plexiglass-Display - mittel

25 x 25 x 51 cm



nous consulter - consult us - Bitte kontaktieren Sie uns

200200PC

1



Présentoir plexiglas horizontal

Horizontal plexiglass display

Horizontales Plexiglass-Display

81,6 x 22,1 x 16,5 cm



nous consulter - consult us - Bitte kontaktieren Sie uns

200010C

1



Mini-stand plastique

Small plastic counter display

Kleiner Kunststoffständer

24 x 34 x 11 cm



nous consulter - consult us
Bitte kontaktieren Sie uns

220000PC

1

220000PC



Tourniquet métallique

Metallic revolving stand

Drehständer aus Metall

44 x 44 x 200 cm



nous consulter - consult us
Bitte kontaktieren Sie uns

221000C

1



Présentoir métallique rotatif 1934

1934 revolving metallic display

Drehendes Metalldisplay 1934

45 x 36 x 56,5 cm



nous consulter - consult us
Bitte kontaktieren Sie uns

223000PC

1



Présentoir métallique White

White metallic display

Metalldisplay Weiß

33 x 61 x 34 cm



260 blocs - pads - Blöcke

201000PC

1



PLV & merchandising

displays

Tourniquet plexiglas modulable

Plexiglass modular revolving stand

Modularer Drehständer aus Plexiglas

Composez, empilez, vissez... c'est prêt !

Tourniquet composé d'éléments individuels en plexiglas, modulables et empilables à souhait, à associer à l'aide de deux simples vis (vis à tête fraisée à six pans)

Compose, stack, screw on... it's ready!

Revolving stand composed by individual plexiglass items, modular and stackable at will, to be joined with two flat-headed screws.

Aufstellen, aufeinander stapeln, zusammenschrauben... fertig!

Drehständer aus einzelnen Plexiglas-Elementen, die modular aufgebaut und beliebig stapelbar sind, mithilfe von zwei einfachen Schrauben zu kombinieren. (Senkkopfschrauben mit Sechskant)

	Grand Large groß	Petit Small klein	
fronton en plexiglas - plexiglass header - Plexiglas-Kopfteil	90071C	92071C	1
logo Rhodia pour fronton - Rhodia logo for header - Rhodia-Logo für Kopfteil	90077C	92077C	4
cube en plexiglas pour format A7 - 4 compartiments - 4 Abschnitte plexiglass cube for A7 - 4 compartments - 4 Abschnitte	90075C	92075C	1
cube en plexiglas pour format A6 - 4 compartiments - 4 Abschnitte plexiglass cube for A6 - 4 compartments - 4 Abschnitte	90074C	92074C	1
cube en plexiglas pour format A5 - 4 compartiments - 4 Abschnitte plexiglass cube for A5 - 4 compartments - 4 Abschnitte	90073C	92073C	1
cube en plexiglas pour format A4 - 4 compartiments - 4 Abschnitte plexiglass cube for A4 - 4 compartments - 4 Abschnitte	90072C	92072C	1
socle en bois, 4 roulettes - wooden 4-wheeled base - Holzsockel, 4 Rollen	90070C	92070C	1

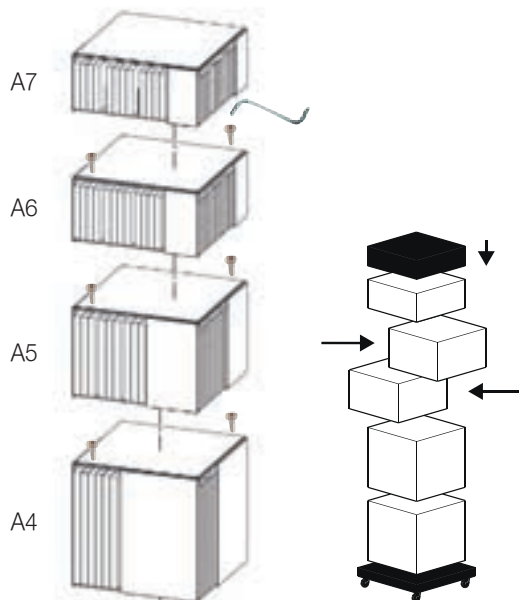

4 tailles de modules disponibles :

A7, A6, A5 et A4 chaque module divisé en 4 compartiments

4 components sizes available:

A7, A6, A5 et A4 each item divided in 4 compartments

4 Modulgrößen verfügbar:

A7, A6, A5 und A4, jedes Modul in 4 Abschnitte unterteilt

Nous consulter pour offres de compositions-types.

Please consult us for type-compositions.

Bitte fragen Sie uns nach der Typengestaltung.

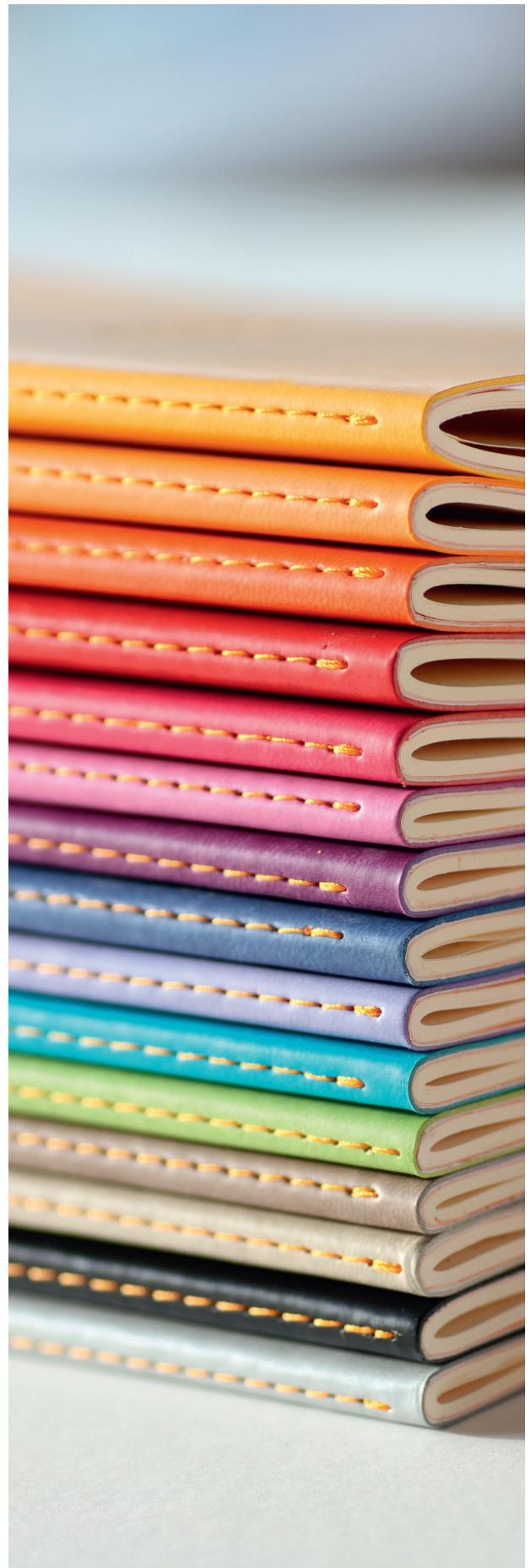

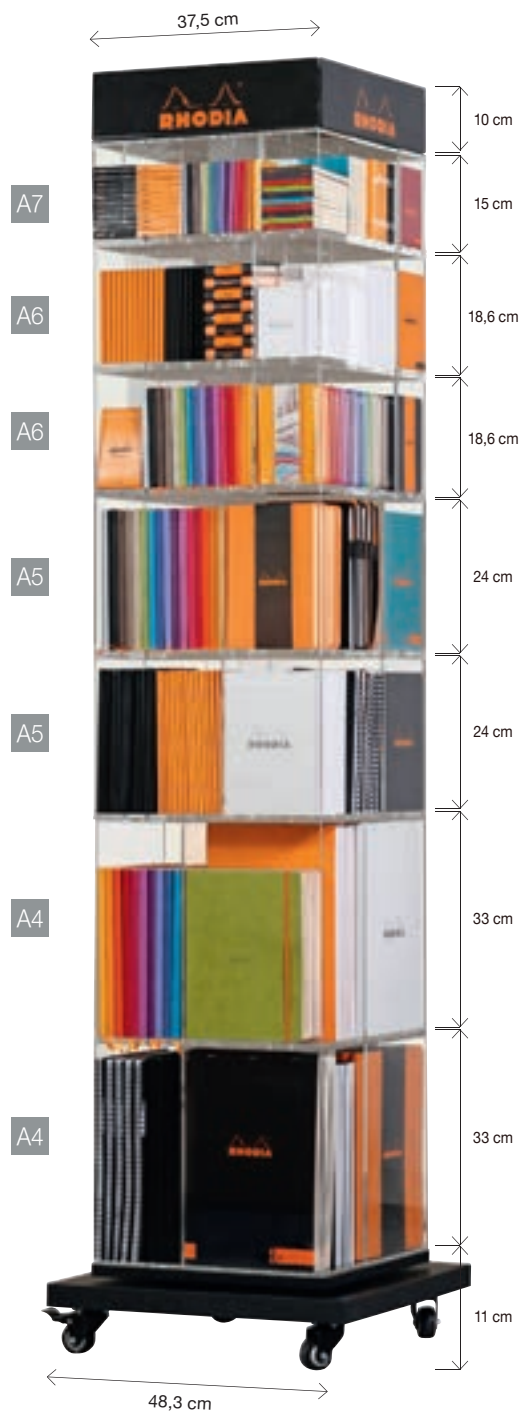

Suggestion de présentation
Suggestion of presentation
Vorschlag einer Präsentation

Grand modèle - Large display Großes Display		
fronton - header - Kopfteil	90071C	1
logos Rhodia - Rhodia logo - Rhodia-Logo	90077C	4
module A7 - A7 component - A7-Modul	90075C	1
module A6 - A6 component - A6-Modul	90074C	2
module A5 - A5 component - A5-Modul	90073C	2
module A4 - A4 component - A4-Modul	90072C	2
socle 4 roulettes - 4-wheeled base - Sockel, 4 Rollen	90070C	1

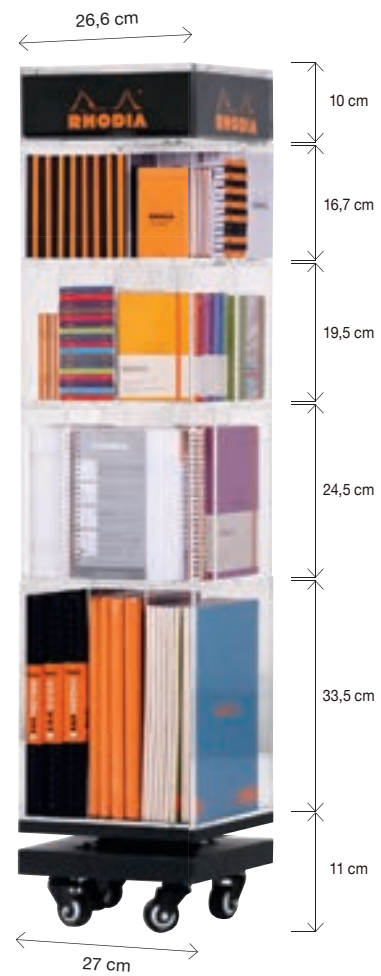

Suggestion de présentation
Suggestion of presentation
Vorschlag einer Präsentation

Petit modèle - Small display Kleines Display		
fronton - header - Kopfteil	92071C	1
logos Rhodia - Rhodia logo - Rhodia-Logo	92077C	4
module A7 - A7 component - A7-Modul	92075C	1
module A6 - A6 component - A6-Modul	92074C	1
module A5 - A5 component - A5-Modul	92073C	1
module A4 - A4 component - A4-Modul	92072C	1
socle 4 roulettes - 4-wheeled base - Sockel, 4 Rollen	92070C	1

Mobilier

concept corner
Mobilier



Découvrez nos nouveaux concepts dans la brochure
« Mobilier & Merchandising » - nous consulter.
*Discover our new concepts in the "POS furniture &
Merchandising" brochure - contact us.*
Entdecken Sie unsere neuen Konzepte in der
Broschüre "POS-Möbel &
Merchandising"-Broschüre - kontaktieren Sie uns.





Suggestion de présentation
Suggestion of presentation
Vorschlag der Präsentation

Mobilier

concept corner
Mobilier

	90605BC	91603BC
Nomenclature Bill of material Stückliste	Étagère bois largeur 0,942 m Wooden shelf width 0,942 m - Holzregal Breite 0,942 m	Ensemble de panneaux intérieurs larg. 0,219 m x haut. 1,35 m Set of interior boards width 0,219 m height 1,35 m - Set Innenwände Breite 0,219 m Höhe 1,35 m
90632AFFRONTC (Logo Rhodia)	90607BC	91617BC
Affichette fronton meuble noir 0,219 m Poster for black display's header 0,219 m - Frontplakat schwarzes Möbelstück 0,219 m	Étagère bois largeur 0,469 m Wooden shelf width 0,469 m - Holzregal Breite 0,469 m	Fronton Métal & Plexi larg. 0,942 m Metal & Plexi header width 0,942 m - Metall- & Plexiglas-Kopfteil 0,942 m
90633AFFRONTC (Logo Rhodia)	90608BC	91618BC
Affichette fronton meuble noir 0,469 m Poster for black display's header 0,469 m - Frontplakat schwarzes Möbelstück 0,469 m	Étagère bois largeur 0,219 m Wooden shelf width 0,219 m - Holzregal Breite 0,219 m	Fronton métal et plexi larg. 0,219 m Metal & Plexi header width 0,219 m - Metall- & Plexiglas-Kopfteil 0,942 m
90634AFFRONTC (Logo Rhodia)	90609BC	91619BC
Affichette fronton meuble noir 0,942 m Poster for black display's header 0,942 m - Frontplakat schwarzes Möbelstück 0,942 m	Bac escalier métal largeur 0,469 m Metal stairs display width 0,469 m - Metall-Prospektständer Breite 0,469 m	Fronton Métal & Plexi larg. 0,469 m Metal & Plexi header width 0,469 m Metall- & Plexiglas-Kopfteil 0,469 m
90600BC	90613BC	91625BC
Panneaux latéraux haut & bas hauteur 2,10 m Top & bottom wooden side panels height 2,10 m - Oben & Unten Seitenwände aus Holz Höhe 2,10 m	Jeu de 10 arceaux métal hauteur 0,45 m Set of 10 metal arches width 0,45 m - 10-er Set Metallböge Breite 0,45 m	Jeu de 11 porte-étiquettes 70 x 27mm Mini Set of 11 label holders 70 x 27mm Short - 11-er Set Etikettenhalter 70 x 27mm Kurz
90601BC	90614BC	92601BC
Barre de charge générique largeur 0,942 m Generic metal load bar width 0,942 m - Generische Metall-Ladestange Breite 0,942 m	Jeu de 10 arceaux métal haut. 0,35 m Set of 10 metal arches width 0,35 m - 10-er Set Metallböge Breite 0,35 m	Ensemble de panneaux intérieurs larg. 0,942 m x haut. 2,10 m Set of interior boards width 0,942 m x height 2,10 m - Set Innenwände Breite 0,942 m x Höhe 2,10 m
90602BC	91600BC	92603BC
Barre de charge métal générique largeur 0,469 m Metal load bar generic width 0,469 m - Generische Metall-Ladestange Breite 0,469 m	Panneaux latéraux haut & bas hauteur 1,35 m Top & bottom wooden side panels height 1,35 m - Oben & unten Seitenwände aus Holz 1,35 m	Ensemble de panneaux intérieurs larg. 0,469 m x haut. 2,10 m Set of interior boards width 0,469 m height 2,10 m - Set Innenwände Breite 0,469 m Höhe 2,10 m
90603BC	91601BC	92604BC
Étagère filaire 0,124 m Mini Metal wire shelf 0,124 m Mini - Drahtregal 0,124 m Mini	Ensemble de panneaux intérieurs larg. 0,942 m x haut. 1,35 m Set of interior boards width 0,942 m height 1,35 m - Set Innenwände Breite 0,942 m Höhe 1,35 m	Ensemble de panneaux intérieurs larg. 0,219 m x haut. 2,10 m Set of interior boards width 0,219 m height 2,10 m - Set Innenwände Breite 0,219 m Höhe 2,10 m



Rhodia Basics

N°1

N°2



N°1	
90600BC *	2
92604BC *	1
91618BC *	1
90608BC *	6
90613BC *	1
90632AFFRONTC *	1
N°2	
90600BC *	2
92601BC *	1
91617BC *	1
90609BC *	2
90601BC *	1
90605BC *	7
90634AFFRONTC *	1

Présentoir bois L. 0,219 x H. 2,10 m

Black wooden display

Schwarzes Holzregal

Mise en avant des nouveautés : par exemple, gamme Rhodia White

Showcasing new products, for instance White collection

Hervorhebung von Neuheiten: z. B. Reihe Rhodia White

Présentoir bois L. 0,942 x H. 2,10 m

Black wooden display

Schwarzes Holzregal

• étagères filaires - Metal wire shelves - Drahtregale

Présentation en facing des formats des gammes blocs agrafés Orange/Black/White

Facing display of Orange/Black/White stapled notepads' size - Facing-Präsentation der Formate der Heftblock-Reihe Orange / Black / White

• étagères bois - Wooden shelves - Holzregale

1. Blocs agrafés White - White head stapled pads - White Heftblöcke
2. Blocs agrafés Orange - Orange head stapled pads - Heftblöcke Orange
3. Blocs agrafés Orange + blocs Pocket - Orange head stapled pads + Pocket pads - Am Kopfende geheftete Blöcke Orange + Taschenblöcke
4. Blocs agrafés Black - Black head stapled pads - Heftblöcke Black
5. Blocs agrafés Black + blocs Pocket - Black head stapled pads + Pocket pads - Am Kopfende geheftete Blöcke Blacke + Taschenblöcke
6. DotPads Orange et Black - Orange and Black dotPads - Dotblöcke Orange und Black
7. Blocs agrafés Orange spécifiques - Orange specific head stapled pads - Am Kopfende geheftete spezielle Blöcke Orange
8. Blocs agrafés Orange + dotPad Black A3 - Orange head stapled pads - Am Kopfende geheftete Blöcke Orange + A3 Black dotPad - A3 DotBlock Schwarz

N°3

N°4



N°3	
90600BC *	2
92603BC *	1
91619BC *	1
90602BC *	1
90609BC *	1
90607BC *	7
90633AFFRONTC *	1
N°4	
90600BC *	2
92603BC *	1
91619BC *	1
90602BC *	1
90609BC *	1
90607BC *	7
90633AFFRONTC *	1

Présentoir bois L. 0,469 x H. 2,10 m

Black wooden display

Schwarzes Holzregal

• étagères filaires - Metal wire shelves - Drahtregale

Présentation en facing des formats de la gamme blocs Le R Orange et Black

Facing display of Orange et Black Le R stapled notepads sizes - Facing-Präsentation der Formate der Block-Reihe R Orange und Black

• étagères bois - Wooden shelves - Holzregale

1. Blocs agrafés Le R Orange N°11, N°12, N°13 et N°16
Orange Le R head stapled pads - Am Kopfende geheftete Blöcke Orange Le R
2. Blocs agrafés Le R Orange N°18 et N°19 - Orange Le R head stapled pads - Am Kopfende geheftete Blöcke Orange Le R
3. Blocs agrafés Le R Black N°11, N°12, N°13 et N°16
Black Le R head stapled pads - Am Kopfende geheftete Blöcke Black Le R
4. Blocs agrafés Le R Black N°18 et N°19 - Black Le R head stapled pads - Am Kopfende geheftete Blöcke Black Le R
5. Porte-blocs ePURE N°11, N°12 - ePure notepad cover - Klemmbrett ePURE Nr. 11, Nr. 12
6. Porte-blocs ePURE N°13, N°8 et N°16 - ePure notepad cover - Klemmbrett ePURE
8. Porte-blocs ePURE N°18 et N°19 - ePure notepad cover - Klemmbrett ePURE

Présentoir bois L. 0,469 x H. 2,10 m

Black wooden display

Schwarzes Holzregal

• étagères filaires - Metal wire shelves - Drahtregale

Présentation en facing des formats de la gamme blocs color

Facing display of colorR stapled notepads sizes - Facing-Präsentation der Formate der Block-Reihe colorR

• étagères bois - Wooden shelves - Holzregale

1. Blocs colorR Framboise N°12, N°16 et N°18 - Raspberry colorR stapled pads
2. Blocs colorR Turquoise N°12, N°16 et N°18 - Turquoise Blue colorR stapled pads - Heftblöcke colorR türkis blau
3. Blocs colorR Chocolat N°16 et N°18 - Chocolate colorR stapled pads - Heftblöcke colorR schokobraun
4. Blocs colorR Coquelicot N°12, N°16 et N°18 - Poppy colorR stapled pads - Heftblöcke colorR Mohn
5. Blocs colorR Violet N°12, N°16 et N°18 - Purple colorR stapled pads - Heftblöcke colorR violet
6. Blocs colorR Anis N°12, N°16 et N°18 - Anise Green colorR stapled pads - Heftblöcke colorR anisgrün
7. Blocs colorR Saphir N°12, N°16 et N°18 - Sapphire Blue colorR stapled pads - Heftblöcke colorR saphirblau
8. Blocs colorR Taupe N°12, N°16 et N°18 - Taupe colorR stapled pads - Heftblöcke colorR taupe

Mobilier

concept corner
Mobilier

Rhodia Classic & Rhodiactive

N°5



N°5	
90600BC *	2
92601BC *	1
91617BC *	1
90601BC *	3
90609BC *	6
90605BC *	1
90634AFFRONTC *	1

Présentoir bois L. 0,942 x H. 2,10 m

Black wooden display

Holzregal

• étagères filaires hautes - Metal wire top shelves - hohe Drahtregale

Présentation en facing de la gamme Rhodia Classic

Facing display of Rhodia Classic collection - Facing-Präsentation der Reihe Rhodia Classic
Cahiers et carnets RI, blocs RI et piqûres

Wirebound notebooks and notepads, staplebound notebooks - Hefte und Notizbücher mit vollständiger Bindung, Blöcke mit vollständiger Bindung, Klammerung

• étagères filaires milieu - Metal wire middle shelves - mittlere Drahtregale

Présentation en facing de la gamme Rhodiactive

Facing display of Rhodiactive collection - Facing-Präsentation der Reihe Rhodiactive
Cahiers, carnets et blocs reliures intégrales

Wirebound notebooks and notepads - Hefte, Notizbücher und Blöcke mit vollständiger Bindung

• étagère bois - Wooden shelf - Holzregal

Brochures rembourrées semi-rigides et brochures rembourrées rigides Rhodiactive

Rhodiactive softback and hardback casebounds - Broschüren mit mittelfestem und festem Einband Rhodiactive

• étagères filaires basse - Metal wire lower shelves - niedrige Drahtregale

Présentation en facing de la gamme Rhodiactive Exabook

Facing display of Exabook range - Facing-Präsentation der Reihe Rhodiactive Exabook

Exabooks et recharges - Exabooks and refill - Exabooks und Nachfüllpacks

Exameeting et recharges - Exameeting and refill - Exameeting und Nachfüllpacks

Rhodia Boutique

N°6



N°6	
90600BC *	2
92603BC *	1
91619BC *	1
90607BC *	5
90609BC *	1
90602BC *	1
90633AFFRONTC *	1

Présentoir bois L. 0,469 x H. 2,10 m

Black wooden display

Schwarzes Holzregal

• étagères filaires - Metal wire shelves - Drahtregale

Présentation en facing de la gamme Webnotebook Orange, Black et Silver - Fa-

cing-Präsentation der Webnotizbuch-Reihe Orange, Black und Silver

Facing display of Orange, Black et Silver Webnotebook range

• étagères bois - Wooden shelves - Holzregale

1. Webbies A7 Orange et Black et A6 Orange, Black et Silver

A7 Orange and Black webnotebooks, A6 Orange, Black and Silver webnotebooks - A7-Webbies Orange und Black, A6-Webbies Orange, Black und Silver

2. Webbies A5 Orange, Black et Silver - A5 Orange, Black and Silver webnotebooks - A5-Webbies Orange, Black und Silver

3. Webbies A4 Orange et Black - A4 Orange and Black webnotebooks - A4-Webbies Orange und Black

4. Webnotepads A6 et A5 Orange et Black - A6 and A5 Orange and Black webnotepads - A6- und A5-Webbies Orange und Black

5. Webnotebooks paysage 14x11cm Orange et Black

14x11cm Orange and Black landscape webnotebooks - Webnotizbücher Querformat 14x11cm Orange und Black

6. Webnotebooks paysage A5 Orange et Black

A5 Orange and Black landscape webnotebooks - Webnotizbücher Querformat Orange und Black

*Voir le détail en p.264 - See details on p.264 - Siehe Einzelheiten auf S. 264

Rhodiarama papeterie & accessoires

Rhodiarama paper products & accessories

Rhodiarama Papierprodukte & Zubehör

N°7

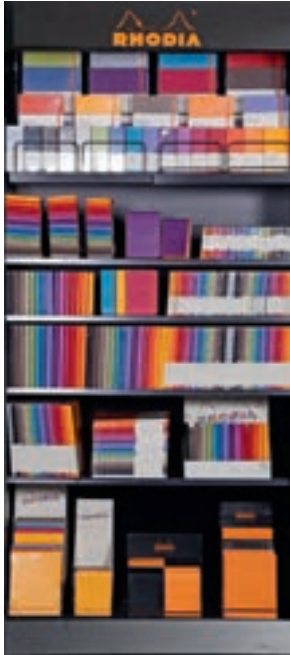

N°7	
90600BC *	2
92601BC *	1
91617BC *	1
90601BC *	1
90609BC *	2
90605BC *	4
90634AFFRONTC *	1

Présentoir bois L. 0,219 x H. 1,35 m

Black wooden display

Schwarzes Holzdisplay

• étagères bois - Wooden shelves - Holzregale

Collection accessoires Home Office

Collection of accessories for the Home Office - Kollektion an Zubehör für das Homeoffice

1. Vide-poches - Reversible tidy - Ablageschale
2. Porte-revues - Magazine rack - Zeitungsständer
3. Sous-mains - Desk blotter - Schreibtischunterlage

Présentoir bois L. 0,942 x H. 2,10 m

Black wooden display

Schwarzes Holzdisplay

• étagères filaires - Metal wire shelves - Drahtregale

Présentation en facing des formats et coloris de la gamme carnets souples Rhodiarama
Facing display of Rhodiarama softcover notebooks sizes and colors - Facing-Display der Rhodiarama Softcover-Notizbücher Größen und Farben

• étagères bois - Wooden shelves - Holzregale

1. Porte-blocs Rhodiarama N°11, N°12 et N°13 et minibooks Rhodiarama Rhodiarama notepad covers N°11, N°12 and N°13 and mini notebooks - Rhodiarama Notizbücher-Einbände Nr. 11, Nr. 12 und Nr. 13 und Mini-Notizbücher
2. Carnets Rhodiarama A6 et carnets souples Rhodiarama A6 A6 Rhodiarama hardcover notebooks and softcover notebooks - A6 Rhodiarama Hardcover-Notizbücher und Softcover-Notizbücher
3. Carnets Rhodiarama A5 et carnets souples Rhodiarama A5 A5 Rhodiarama hardcover notebooks and softcover notebooks - A5 Rhodiarama Hardcover-Notizbücher und Softcover-Notizbücher
4. Carnets souples Rhodiarama 19x25 cm et carnets Rhodiarama A6 19x25 cm Rhodiarama softcover notebooks and A6 Rhodiarama hardcover notebooks - 19x25 cm Rhodiarama Softcover-Notizbücher und A6 Rhodiarama-Notizbücher
5. Webpockets Rhodiarama et Webpockets Orange et Black A6 et A5 A6 and A5 Rhodiarama Webpockets and Orange and Black Webpockets - Webpockets Rhodiarama und Webpocketss Orange und Black A6 und A5

N°8	
91600BC *	2
91603BC *	1
90608BC *	2



N°8

Rhodiarama accessoires et home office

Rhodiarama accessories & home office

Rhodiarama Zubehör & Homeoffice

N°9



N°9	
91600BC *	2
91601BC *	1
90605BC *	2

Présentoir bois L. 0,942 x H. 1,35 m

Black wooden display

Schwarzes Holzregal

• étagères bois - Wooden shelves - Holzregale

1. Plumiers, trousse, vide-poches, pots à crayons pencil holder, pencil cases, tidies, pencil boxes - Federtaschen, Federmäppchen, Ablagen, Stiftbehälter
2. Porte-courrier, porte-magazines letter holders, magazine racks - Briefhalter, Zeitschriftenständer
3. Corbeilles, trieurs, set de boîtes Waste bins, storage boxes, set of boxes - Papierkörbe, Aufbewahrungsboxen, Boxen-Sets

*Voir le détail en p.264 - See details on p.264 - Siehe Einzelheiten auf S. 264

Afrique du Sud / South Africa / Südafrika
Allemagne / Germany / Deutschland
Andorre / Andorra / Andorra
Australie / Australia / Australien
Belgique / Belgium / Belgien
Bénin / Benin / Benin
Biélorussie / Belarus / Weißrussland
Brésil / Brazil / Brasilien
Burkina Faso / Burkina Faso
Canada / Kanada
Chili / Chile / Chila
Chypre / Cyprus / Zypern
Corée du Sud / South Korea / Südkorea
Côte d'Ivoire / Ivory Coast / Elfenbeinküste
Croatie / Croatia / Kroatien
Danemark / Denmark / Dänemark
Égypte / Egypt / Ägypten
Émirats arabes unis / United Arab Emirates /
Vereinigte Arabische Emirate
Espagne / Spain / Spanien
États-Unis / United States / Vereinigte Staaten

Fédération de Russie / Russian Federation /
Russische Föderation
Finlande / Finland / Finnland
France / Frankreich
Gabon / Gabun
Géorgie / Georgia / Georgien
Ghana / Ghana
Grèce / Greece / Griechenland
Guadeloupe / Guadeloupe
Guyane Française / French Guiana / Französisch-
Guayana
Haïti / Haiti / Haiti
Hong-Kong / Hong Kong / Hong Kong
Hongrie / Hungary / Ungarn
Inde / India / Indien
Indonésie / Indonesia / Indonesien
Irlande / Ireland / Irland
Islande / Iceland / Island
Israël / Israel / Israel

Italie / Italy / Italien
Japon / Japan / Japan
Jordanie / Jordan / Jordanien
Lettonie / Latvia / Lettland
Luxembourg / Luxembourg
Malaisie / Malaysia / Malaysia
Malte / Malta / Malta
Maroc / Morocco / Marokko
Martinique / Martinique
Mayotte / Mayotte
Monaco / Monaco
Mongolie / Mongolia / Mongolei
Norvège / Norway / Norwegen
Nouvelle-Calédonie / New Caledonia / Neukaledonien
Nouvelle-Zélande / New Zealand / Neuseeland
Pays-Bas / Netherlands / Niederlande
Pologne / Poland / Polen
Polynésie française / French Polynesia / Französisch-
Polynisien
Portugal / Portugal
Qatar / Katar
République du Congo / Republic of Congo / Republik
Kongo
République tchèque / Czech Republic / Tschechei
Réunion / Reunion Island / Réunion
Roumanie / Romania / Rumänien
Royaume-Uni / United Kingdom / Vereinigtes
Königreich
Saint-Barthélemy / Saint Barthélemy / Saint
Barthélemy
Saint-Martin / Saint-Martin
Sénégal / Senegal / Senegal
Singapour / Singapore / Singapur
Slovénie / Slovenia / Slowenien
Suède / Sweden / Schweden
Suisse / Switzerland / Schweiz
Taiwan / Taiwan / Taiwan
Thaïlande / Thailand / Thailand
Turquie / Turkey / Türkei
Ukraine / Ukraine / Ukraine
Viêtnam / Vietnam / Vietnam



Extra-ordinaire depuis 1934...

Fabriqué en France depuis toujours, l'iconique bloc agrafé Rhodia aura su conquérir la planète, du Japon aux États-Unis, de l'Inde à l'Australie, de la Mongolie aux Émirats arabes unis, du Chili à la Malaisie, de la Fédération russe au Canada, du Brésil à la Corée du Sud, en passant par toute l'Europe... tout en gardant son cœur et ses racines en France. Année après année, la « marque aux deux sapins » poursuit son tour du monde, portée par l'excellence de son savoir-faire papetier conjuguée à l'authenticité et au style distinctif de ses collections.

Extra-ordinary since 1934...

Manufactured in France since the beginning, the iconic Rhodia stapled notepad has won hearts, from Japan to the United States, from India to Australia, from Mongolia to the United Arab Emirates, from Chile to Malaysia, from the Russian Federation to Canada, from Brazil to South Korea, passing through all of Europe as well... while keeping its heart and roots in France. Year after year, the «brand with the two fir trees» continues its world tour, driven by the excellence of its papermaking know-how combined with the authenticity and distinctive style of its collections.

Außergewöhnlich seit 1934...

Der ikonische, seit jeher in Frankreich hergestellte Rhodia-Heftblock hat die Welt erobert, von Japan bis zu den Vereinigten Staaten, von Indien bis Australien, von der Mongolei bis zu den Vereinigten Arabischen Emiraten, von Chile bis Malaysia, von der Russischen Föderation bis Kanada, von Brasilien bis Südkorea, quer durch Europa... und dabei sein Herz und seine Wurzeln immer in Frankreich behalten. Jahr für Jahr setzt die «Marke mit den zwei Tannenbäumen» ihre Weltreise fort, angetrieben von der Exzellenz ihres papiermacherischen Know-hows im Zusammenspiel mit der Authentizität und dem unverwechselbaren Stil ihrer Kollektionen.

Canada



Espagne

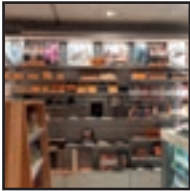

Royaume-Uni

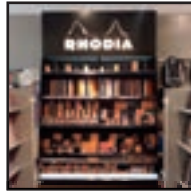

France



Allemagne



USA

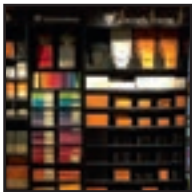

Chili



Japon

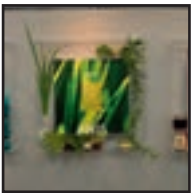

Brésil

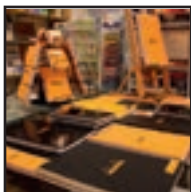

Irak



Maroc



Émirats arabes unis

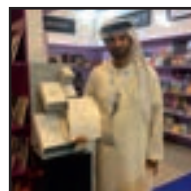

Oman



Rhodia dans le monde

Roumanie

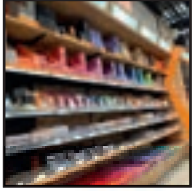

Ukraine



Hongrie



Chine



Mongolie



Thaïlande

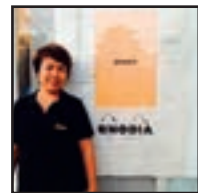

Corée du Sud

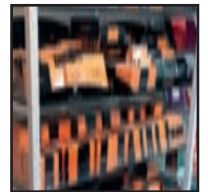

Malaisie



Taiwan

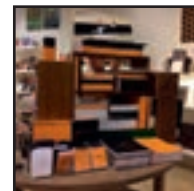

Australie



Turquie



Nouvelle-Zélande



Hong Kong



index

référence item number	page	référence item number	page	référence item number	page	référence item number	page	référence item number	page	référence item number	page
8200C	32	11600C	32	19052C	75	90633AFFRONTC	264	116123C	228	116175C	212
8220C	58	11601C	38	19056C	75	90634AFFRONTC	264	116124C	230	116176C	212
8228C	58	11920C	70	19200C	32	91600BC	264	116125C	230	116177C	212
8229C	58	12168C	62	19201C	38	91601BC	264	116126C	232	116178C	214
8550C	58	12169C	62	19248C	62	91603BC	264	116127C	232	116179C	214
8558C	58	12200C	32	19249C	62	91617BC	264	116128C	232	116180C	214
8559C	58	12201C	38	19300C	51	91619BC	264	116129C	234	116181C	214
8600C	32	12558C	44	19310C	51	91625BC	264	116131C	238	116182C	214
8650C	58	12559C	44	19320C	52	92001C	37	116132C	238	116183C	214
8669C	58	12600C	32	19341C	52	92070C	260	116134C	168	116184C	214
8680C	58	12601C	38	19342C	51	92071C	260	116135C	168	116185C	214
9020C	114	13200C	32	19346C	51	92072C	260	116136C	204	116186C	210
9200C	37	13201C	38	19360C	53	92073C	260	116137C	204	116187C	210
9201C	37	13500C	53	19400C	40	92074C	260	116138C	204	116188C	210
9280C	112	13503C	53	19401C	40	92075C	260	116139C	204	116189C	210
9282C	112	13600C	32	19410C	59	92077C	261	116140C	204	116192C	235
9283C	99	13601C	38	19526C	75	92077C	260	116141C	204	116193C	236
9284C	99	13920C	70	19558C	44	92601BC	264	116142C	204	116194C	236
9301C	115	14200C	32	19559C	44	92603BC	264	116143C	204	116401C	138
9302C	115	14600C	32	19600C	32	92604BC	264	116144C	206	116402C	138
9303C	115	15200C	32	19601C	38	100002PC	36	116145C	206	116403C	138
9340C	99	15600C	32	19660C	43	100006PC	36	116146C	206	116404C	138
9342C	99	16000C	32	19920C	70	102009C	34	116147C	206	116405C	138
9344C	99	16200C	32	20100C	42	106009C	34	116148C	206	116406C	138
9345C	98	16201C	38	20200C	42	112009C	34	116149C	206	116407C	138
9360C	100	16260C	43	24328C	62	112011C	46	116150C	206	116408C	138
9370C	101	16400C	40	24329C	62	112012C	46	116151C	206	116409C	138
9381C	112	16401C	40	38200C	32	115009C	53	116152C	208	116410C	138
9382C	115	16500C	53	38559C	44	115039C	53	116153C	208	116411C	138
9383C	106	16501C	53	40152C	254	116009C	34	116154C	200	116412C	138
9384C	108	16503C	53	82009C	34	116100C	216	116155C	200	116413C	138
9385C	110	16558C	44	86009C	34	116101C	216	116156C	200	116414C	138
9386C	104	16559C	44	90070C	260	116102C	218	116157C	200	116415C	138
9387C	102	16600C	32	90071C	260	116103C	218	116158C	200	116416C	138
9388C	112	16601C	38	90072C	260	116104C	218	116159C	200	116451C	138
9389C	112	16920C	70	90073C	260	116105C	218	116160C	200	116452C	138
9391C	113	16921C	70	90074C	260	116106C	220	116161C	200	116453C	138
9393C	107	18000C	32	90075C	260	116107C	220	116162C	202	116454C	138
9394C	109	18200C	32	90077C	260	116108C	220	116163C	202	116455C	138
9395C	111	18201C	38	90600BC	264	116109C	220	116164C	202	116456C	138
9396C	105	18500C	53	90601BC	264	116110C	222	116165C	202	116457C	138
9397C	103	18501C	53	90602BC	264	116111C	222	116166C	202	116458C	138
9398C	113	18503C	53	90603BC	264	116112C	222	116167C	202	116459C	138
9399C	113	18558C	44	90605BC	264	116113C	222	116168C	202	116460C	138
10200C	32	18559C	44	90607BC	264	116114C	224	116169C	202	116461C	138
10600C	32	18600C	32	90608BC	264	116115C	224	116170C	212	116462C	138
11200C	32	18601C	38	90609BC	264	116116C	226	116171C	212	116463C	138
11201C	38	19000C	32	90613BC	264	116117C	226	116172C	212	116464C	138
11500C	53	19005C	242	90614BC	264	116118C	226	116173C	212	116465C	138
11503C	53	19006C	243	90632AFFRONTC	264	116122C	228	116174C	212	116466C	138

index

référence item number	page	référence item number	page	référence item number	page	référence item number	page	référence item number	page	référence item number	page
116517C	164	116635C	164	117184C	142	117366C	133	117455C	134	117571C	129
116518C	164	116636C	164	117185C	142	117370C	134	117456C	134	117572C	129
116519C	164	116637C	164	117186C	142	117370PC	134	117457C	134	117573C	129
116520C	164	116638C	164	117187C	142	117371C	134	117458C	134	117574C	129
116521C	164	116639C	164	117188C	142	117372C	134	117459C	134	117575C	129
116522C	164	116640C	164	117189C	142	117373C	134	117460C	134	117576C	129
116523C	164	116641C	164	117190C	142	117374C	134	117461C	134	117577C	129
116524C	164	116642C	164	117191C	142	117375C	134	117462C	134	117578C	129
116525C	164	116643C	164	117192C	142	117376C	134	117463C	134	117579C	129
116526C	164	116644C	164	117193C	142	117377C	134	117464C	134	117580C	129
116527C	164	116645C	164	117194C	142	117378C	134	117465C	134	117581C	129
116528C	164	116646C	164	117195C	142	117379C	134	117466C	134	117582C	129
116529C	164	116647C	164	117196C	142	117380C	134	117476C	134	117583C	129
116530C	164	116648C	164	117201C	132	117382C	134	117477C	134	117584C	129
116531C	164	116717C	164	117203C	132	117383C	134	117478C	134	117585C	129
116532C	164	116718C	164	117205C	132	117384C	134	117479C	134	117701C	137
116533C	164	116719C	164	117207C	132	117385C	134	117480C	134	117702C	137
116534C	164	116720C	164	117209C	132	117386C	134	117501C	136	117703C	137
116535C	164	116721C	164	117211C	132	117401C	134	117502C	136	117704C	137
116536C	164	116722C	164	117213C	132	117402C	134	117503C	136	117705C	137
116537C	164	116723C	164	117215C	132	117403C	134	117504C	136	117706C	137
116538C	164	116724C	164	117301C	133	117404C	134	117505C	136	117707C	137
116539C	164	116725C	164	117302C	133	117405C	134	117506C	136	117708C	137
116540C	164	116726C	164	117303C	133	117406C	134	117507C	136	117709C	137
116541C	164	116727C	164	117304C	133	117407C	134	117508C	136	117710C	137
116542C	164	116728C	164	117305C	133	117408C	134	117509C	136	117711C	137
116543C	164	116729C	164	117306C	133	117409C	134	117510C	136	117712C	137
116544C	164	116730C	164	117307C	133	117410C	134	117511C	136	117713C	137
116545C	164	116731C	164	117308C	133	117411C	134	117512C	136	117714C	137
116546C	164	116732C	164	117310C	133	117412C	134	117513C	136	117715C	137
116547C	164	116733C	164	117311C	133	117413C	134	117514C	136	117716C	137
116548C	164	116734C	164	117312C	133	117414C	134	117515C	136	117740C	142
116617C	164	116735C	164	117313C	133	117415C	134	117516C	136	117741C	129
116618C	164	116736C	164	117314C	133	117416C	134	117551C	136	117742C	129
116619C	164	116737C	164	117315C	133	117436C	134	117552C	136	117743C	129
116620C	164	116738C	164	117316C	133	117436PC	134	117553C	136	117744C	129
116621C	164	116739C	164	117351C	133	117437C	134	117554C	136	117745C	129
116622C	164	116740C	164	117352C	133	117438C	134	117555C	136	117746C	129
116623C	164	116741C	164	117353C	133	117439C	134	117556C	136	117747C	129
116624C	164	116742C	164	117354C	133	117440C	134	117557C	136	117748C	129
116625C	164	116743C	164	117355C	133	117441C	134	117558C	136	117749C	129
116626C	164	116744C	164	117357C	133	117442C	134	117559C	136	117750C	129
116627C	164	116745C	164	117358C	133	117443C	134	117560C	136	117751C	129
116628C	164	116746C	164	117359C	133	117444C	134	117561C	136	117752C	129
116629C	164	116747C	164	117360C	133	117445C	134	117562C	136	117753C	129
116630C	164	116748C	164	117361C	133	117446C	134	117563C	136	117754C	129
116631C	164	117021C	140	117362C	133	117451C	134	117564C	136	117755C	129
116632C	164	117181C	142	117363C	133	117452C	134	117565C	136	117756C	129
116633C	164	117182C	142	117364C	133	117453C	134	117566C	136	117761C	129
116634C	164	117183C	142	117365C	133	117454C	134	117570C	129	117762C	129

index

référence item number	page	référence item number	page	référence item number	page	référence item number	page	référence item number	page	référence item number	page
117763C	129	118029C	145	118210C	156	118632C	146	118776C	129	119181C	50
117764C	129	118038C	145	118211C	156	118633C	146	118777C	129	119182C	50
117765C	129	118049C	145	118212C	156	118634C	146	118778C	129	119183C	50
117766C	129	118058C	56	118213C	156	118635C	146	118779C	129	119184C	50
117767C	129	118059C	56	118214C	156	118636C	146	118780C	129	119186C	50
117768C	129	118067C	144	118216C	156	118642C	146	118781C	129	119187C	50
117769C	129	118068C	144	118248C	147	118643C	146	118782C	129	119188C	50
117770C	129	118069C	144	118308C	148	118644C	146	118783C	129	119189C	50
117771C	129	118078C	144	118309C	148	118645C	146	118784C	129	119190C	50
117772C	129	118079C	144	118318C	158	118646C	146	118785C	129	119200C	50
117773C	129	118098C	158	118319C	158	118647C	146	118786C	129	119208C	54
117774C	129	118099C	158	118348C	148	118648C	146	118800C	186	119209C	54
117775C	129	118101C	156	118349C	148	118649C	146	118806C	186	119218C	54
117776C	129	118103C	156	118368C	144	118650C	146	118810C	178	119219C	54
117781C	140	118104C	156	118369C	144	118651C	146	118816C	178	119228C	54
117782C	140	118105C	156	118449C	166	118652C	146	118820C	188	119229C	54
117783C	140	118106C	156	118468C	144	118653C	146	118826C	188	119230C	77
117784C	140	118107C	156	118558C	56	118654C	146	118830C	182	119231C	77
117785C	140	118108C	156	118559C	56	118655C	146	118836C	182	119232C	77
117786C	140	118109C	156	118567C	144	118656C	146	118840C	180	119233C	77
117787C	140	118110C	156	118568C	144	118668C	144	118846C	180	119236C	76
117788C	140	118111C	156	118569C	144	118669C	144	118850C	30	119237C	76
117789C	140	118112C	156	118570C	129	118724C	146	118858C	56	119238C	76
117790C	140	118113C	156	118571C	129	118725C	146	118860C	190	119248C	54
117791C	140	118114C	156	118572C	129	118729C	146	118866C	190	119249C	54
117792C	140	118116C	156	118573C	129	118731C	146	118868C	144	119600C	42
117793C	140	118118C	156	118574C	129	118734C	146	118869C	144	119660C	42
117794C	140	118119C	156	118575C	129	118735C	146	118870C	176	119700C	42
117795C	140	118128C	156	118576C	129	118736C	146	118876C	176	119900C	71
117796C	140	118129C	156	118577C	129	118742C	146	118880C	192	119901C	71
117800C	129	118138C	156	118578C	129	118743C	146	118886C	192	119910C	71
117801C	129	118139C	156	118579C	129	118744C	146	118958C	56	119911C	71
117802C	129	118148C	158	118580C	129	118745C	146	118968C	56	119912C	68
117803C	129	118149C	158	118581C	129	118746C	146	118969C	56	119913C	68
117804C	129	118168C	158	118582C	129	118747C	146	118978C	56	119914C	68
117805C	129	118169C	158	118583C	129	118748C	146	118979C	56	119915C	68
117806C	129	118178C	145	118584C	129	118750C	146	119151C	50	119920C	73
117807C	129	118179C	145	118585C	129	118751C	146	119152C	50	119930C	72
117808C	129	118188C	158	118607C	144	118752C	146	119153C	50	119931C	72
117809C	129	118189C	158	118608C	144	118753C	146	119155C	50	119940C	71
117810C	129	118198C	158	118609C	144	118758C	56	119156C	50	119941C	71
117811C	129	118199C	158	118623C	146	118759C	56	119158C	50	119960C	72
117812C	129	118201C	156	118624C	146	118767C	144	119159C	50	119970C	73
117813C	129	118203C	156	118625C	146	118768C	144	119163C	50	120025C	250
117814C	129	118204C	156	118626C	146	118769C	144	119164C	50	120026C	250
117815C	129	118205C	156	118627C	146	118771C	129	119165C	50	120027C	249
118014C	41	118206C	156	118628C	146	118772C	129	119166C	50	120028C	249
118015C	41	118207C	156	118629C	146	118773C	129	119167C	50	120029C	249
118016C	41	118208C	156	118630C	146	118774C	129	119168C	50	120030C	249
118028C	145	118209C	156	118631C	146	118775C	129	119169C	50	120031C	248

index

référence item number	page	référence item number	page	référence item number	page	référence item number	page	référence item number	page	référence item number	page
120032C	248	133142C	66	166009C	34	193428C	51	194185C	150	194244C	184
120033C	249	133146C	66	168100C	152	193429C	51	194186C	150	194245C	184
120034C	249	133151C	66	168101C	152	193439C	51	194187C	150	194246C	184
120035C	248	133572C	66	168102C	152	193441C	51	194188C	150	194247C	84
120036C	251	133576C	66	168103C	152	193448C	51	194189C	150	194248C	84
120037C	251	135009C	53	168104C	152	193461C	51	194190C	150	194249C	84
120038C	251	135039C	53	168105C	152	193468C	51	194191C	150	194250C	84
120039C	251	136009C	34	168106C	152	193469C	51	194192C	150	194251C	84
120040C	250	138101C	156	168107C	152	193608C	53	194193C	150	194252C	84
120041C	250	138103C	156	168108C	152	193609C	53	194194C	150	194253C	84
122008C	46	138104C	156	168116C	152	193638C	53	194195C	150	194254C	84
122009C	34	138105C	156	168117C	152	193639C	53	194197C	150	194255C	82
122011C	46	138106C	156	168118C	152	194009C	40	194198C	150	194256C	82
122012C	46	138107C	156	168119C	152	194040C	86	194199C	150	194257C	82
126009C	34	138108C	156	168120C	152	194041C	86	194200C	150	194258C	82
128101C	156	138109C	156	168121C	152	194042C	88	194201C	150	194259C	82
128103C	156	138110C	156	168122C	152	194043C	90	194202C	150	194260C	82
128104C	156	138111C	156	168123C	152	194044C	90	194203C	150	194261C	82
128105C	156	138112C	156	168124C	152	194045C	90	194204C	150	194262C	82
128106C	156	138113C	156	180009C	34	194046C	90	194205C	150	194264C	184
128107C	156	138114C	156	182007C	46	194047C	90	194207C	150	194265C	184
128108C	156	138116C	156	182008C	46	194048C	90	194208C	150	194266C	184
128109C	156	138201C	156	182009C	34	194049C	92	194209C	150	194267C	184
128110C	156	138203C	156	182012C	46	194050C	92	194210C	150	194268C	184
128111C	156	138204C	156	185009C	53	194051C	92	194211C	150	194269C	184
128112C	156	138205C	156	185019C	53	194052C	92	194212C	150	194270C	184
128113C	156	138206C	156	185039C	53	194053C	92	194213C	150	194271C	184
128114C	156	138207C	156	186009C	34	194054C	92	194214C	150	194272C	184
128116C	156	138208C	156	190009C	34	194134C	84	194215C	150	194273C	184
128201C	156	138209C	156	190401C	75	194135C	84	194216C	82	194274C	184
128203C	156	138210C	156	191000C	43	194137C	84	194217C	82	194275C	184
128204C	156	138211C	156	191301C	74	194138C	84	194218C	82	194276C	184
128205C	156	138212C	156	191310C	74	194139C	84	194219C	82	194277C	184
128206C	156	138213C	156	192009C	34	194140C	84	194220C	82	194278C	184
128207C	156	138214C	156	193001C	51	194141C	84	194221C	82	194279C	184
128208C	156	138216C	156	193008C	51	194142C	84	194222C	82	194307C	184
128209C	156	140000C	43	193009C	51	194150C	124	194223C	82	194308C	184
128210C	156	142009C	34	193039C	51	194151C	124	194230C	184	194309C	184
128211C	156	146009C	34	193101C	51	194152C	124	194231C	184	194310C	184
128212C	156	148200C	32	193108C	51	194153C	124	194232C	184	194311C	184
128213C	156	148209C	34	193109C	51	194154C	124	194233C	184	194312C	184
128214C	156	160009C	34	193118C	51	194155C	124	194234C	184	194313C	184
128216C	156	162007C	46	193308C	52	194156C	124	194235C	184	194314C	184
132009C	34	162008C	46	193309C	52	194157C	124	194237C	184	194315C	184
132142C	66	162009C	34	193408C	52	194158C	124	194238C	184	194316C	184
132146C	66	162012C	46	193409C	52	194159C	124	194239C	184	194317C	184
132151C	66	164009C	40	193411C	52	194160C	124	194240C	184	194318C	184
132401C	67	165009C	53	193418C	52	194182C	150	194241C	184	194319C	184
132572C	66	165019C	53	193419C	52	194183C	150	194242C	184	194320C	184
132576C	66	165039C	53	193421C	51	194184C	150	194243C	184	194321C	184

index

référence item number	page	référence item number	page	référence item number	page	référence item number	page	référence item number	page	référence item number	page
194322C	184	194389C	148	194447C	126	194539C	182	194589C	30	210200C	32
194340C	148	194390C	148	194448C	126	194540C	182	194590C	30	210209C	34
194341C	148	194391C	148	194449C	126	194541C	182	194591C	30	211001C	154
194342C	148	194392C	148	194450C	126	194542C	182	194592C	30	211002C	154
194343C	148	194393C	148	194475C	186	194543C	182	194593C	30	211003C	154
194344C	148	194394C	148	194476C	186	194544C	182	194594C	30	211004C	154
194345C	148	194395C	148	194477C	186	194545C	182	194595C	30	211005C	154
194346C	148	194397C	148	194478C	186	194546C	182	194597C	30	211006C	154
194347C	148	194398C	148	194479C	186	194547C	182	194598C	30	211007C	154
194348C	148	194399C	148	194480C	186	194548C	182	194599C	180	211008C	154
194349C	148	194400C	148	194481C	186	194549C	182	194600C	180	211009C	154
194350C	148	194401C	148	194482C	186	194550C	182	194601C	180	212001C	154
194351C	148	194402C	172	194483C	186	194551C	182	194602C	180	212002C	154
194352C	148	194403C	172	194484C	186	194552C	182	194603C	180	212003C	154
194353C	148	194404C	172	194485C	186	194553C	192	194604C	180	212004C	154
194354C	148	194405C	172	194486C	186	194554C	192	194605C	180	212005C	154
194355C	148	194407C	172	194487C	186	194555C	192	194607C	180	212006C	154
194356C	148	194409C	172	194488C	186	194556C	192	194608C	180	212007C	154
194357C	148	194410C	172	194489C	186	194557C	192	194609C	180	212008C	154
194358C	148	194411C	172	194507C	176	194558C	192	194610C	180	212009C	154
194359C	148	194412C	172	194508C	176	194559C	192	194611C	180	213001C	154
194360C	148	194413C	172	194509C	176	194560C	192	194612C	180	213002C	154
194361C	148	194414C	172	194510C	176	194561C	192	194613C	180	213003C	154
194362C	148	194415C	172	194511C	176	194562C	192	194614C	180	213004C	154
194363C	148	194416C	172	194512C	176	194563C	192	194615C	188	213005C	154
194364C	148	194417C	172	194513C	176	194564C	192	194616C	188	213006C	154
194365C	148	194418C	172	194514C	176	194565C	192	194617C	188	213007C	154
194366C	148	194419C	172	194515C	176	194566C	192	194618C	188	213008C	154
194367C	148	194420C	172	194516C	176	194567C	192	194619C	188	213009C	154
194368C	148	194421C	172	194517C	176	194568C	190	194620C	188	216001C	154
194369C	148	194422C	172	194518C	176	194569C	190	194621C	188	216002C	154
194370C	148	194423C	172	194519C	176	194570C	190	194622C	188	216003C	154
194371C	148	194424C	172	194520C	176	194571C	190	194623C	188	216004C	154
194372C	148	194425C	172	194521C	176	194572C	190	194624C	188	216005C	154
194373C	148	194426C	172	194522C	178	194573C	190	194625C	188	216006C	154
194374C	148	194427C	172	194523C	178	194574C	190	194626C	188	216007C	154
194375C	148	194428C	172	194524C	178	194575C	190	194627C	188	216008C	154
194376C	148	194429C	172	194525C	178	194576C	190	194628C	188	216009C	154
194377C	148	194430C	172	194526C	178	194577C	190	194629C	188	218098C	158
194378C	148	194431C	172	194527C	178	194578C	190	196009C	34	218099C	158
194380C	148	194432C	172	194528C	178	194579C	190	200010C	258	218118C	156
194381C	148	194433C	172	194529C	178	194580C	190	200097C	36	218119C	156
194382C	148	194435C	172	194530C	178	194581C	190	200099PC	36	218128C	156
194383C	148	194440C	126	194531C	178	194582C	190	200200PC	258	218129C	156
194384C	148	194441C	126	194532C	178	194583C	30	201000C	38	218138C	156
194384PC	148	194442C	126	194533C	178	194584C	30	201000PC	38	218139C	156
194385C	148	194443C	126	194534C	178	194585C	30	201009C	42	218168C	158
194386C	148	194444C	126	194535C	178	194586C	30	202009C	42	218169C	158
194387C	148	194445C	126	194537C	178	194587C	30	206009C	42	218188C	158
194388C	148	194446C	126	194538C	182	194588C	30	210000PC	258	218189C	158

référence item number	page	référence item number	page	référence item number	page	référence item number	page	référence item number	page	référence item number	page
218198C	158	250063C	239	318838C	182	318897C	162	318986C	192	319042C	160
218199C	158	250064C	239	318839C	182	318898C	162	318990C	162	319043C	162
220000C	259	250065C	239	318841C	180	318899C	162	318991C	162	319044C	162
220000PC	259	250066C	239	318843C	180	318900C	186	318992C	162	319045C	162
221000C	259	250067C	239	318844C	180	318901C	186	318993C	162	319046C	162
223000C	259	250068C	239	318845C	180	318902C	186	318994C	162	319047C	162
223000PC	259	250069C	239	318846C	180	318903C	186	318996C	162	319780C	176
230000C	254	250070C	239	318847C	180	318904C	186	319000C	162	319781C	176
230001C	254	250071C	239	318848C	180	318906C	186	319001C	162	319782C	176
232000C	254	250072C	239	318849C	180	318910C	178	319002C	162	319783C	176
240000C	254	250075C	257	318851C	30	318911C	178	319003C	162	319784C	176
240001C	254	250076C	257	318853C	30	318912C	178	319004C	162	319786C	176
240002C	254	250077C	257	318854C	30	318913C	178	319005C	162	999939C	168
240003C	254	250078C	257	318855C	30	318914C	178	319006C	162	90070C	260
240004C	254	250079C	238	318856C	30	318916C	178	319007C	162	90071C	260
240005C	254	250080C	238	318857C	30	318920C	188	319008C	162	90072C	260
240006C	254	250081C	238	318858C	30	318921C	188	319009C	162	90073C	260
250000C	256	250082C	238	318859C	30	318922C	188	319010C	162	90074C	260
250001C	256	250083C	257	318861C	190	318923C	188	319011C	160	90075C	260
250006C	256	250084C	257	318863C	190	318924C	188	319012C	160	91618BC	264
250007C	256	318801C	186	318864C	190	318926C	188	319013C	160	92070C	260
250008C	257	318803C	186	318865C	190	318930C	182	319014C	160	92071C	260
250009C	257	318804C	186	318866C	190	318931C	182	319015C	160	92077C	260
250017C	257	318805C	186	318867C	190	318932C	182	319016C	160	RCDIVERS36	238
250019C	256	318806C	186	318868C	190	318933C	182	319017C	160		
250020C	256	318807C	186	318869C	190	318934C	182	319018C	160		
250033C	257	318808C	186	318871C	176	318936C	182	319019C	160		
250034C	257	318809C	186	318873C	176	318940C	180	319020C	160		
250036C	256	318811C	178	318874C	176	318941C	180	319021C	160		
250037C	256	318813C	178	318875C	176	318942C	180	319022C	160		
250038C	256	318814C	178	318876C	176	318943C	180	319023C	160		
250039C	256	318815C	178	318877C	176	318944C	180	319024C	160		
250040C	256	318816C	178	318878C	176	318946C	180	319025C	160		
250045C	257	318817C	178	318879C	176	318950C	30	319026C	160		
250046C	257	318818C	178	318881C	192	318951C	30	319027C	160		
250047C	168	318819C	178	318883C	192	318952C	30	319028C	160		
250048C	168	318821C	188	318884C	192	318953C	30	319029C	160		
250050C	256	318823C	188	318885C	192	318954C	30	319030C	160		
250051C	168	318824C	188	318886C	192	318956C	30	319031C	160		
250052C	168	318825C	188	318887C	192	318960C	190	319032C	160		
250053C	239	318826C	188	318888C	192	318961C	190	319033C	160		
250054C	239	318827C	188	318889C	192	318962C	190	319034C	160		
250055C	239	318828C	188	318890C	162	318963C	190	319035C	160		
250056C	239	318829C	188	318891C	162	318964C	190	319036C	160		
250057C	239	318831C	182	318891PC	162	318966C	190	319037C	160		
250058C	239	318833C	182	318892C	162	318980C	192	319038C	160		
250059C	239	318834C	182	318893C	162	318981C	192	319038PC	160		
250060C	239	318835C	182	318894C	162	318982C	192	319039C	160		
250061C	239	318836C	182	318895C	162	318983C	192	319040C	160		
250062C	239	318837C	182	318896C	162	318984C	192	319041C	160		

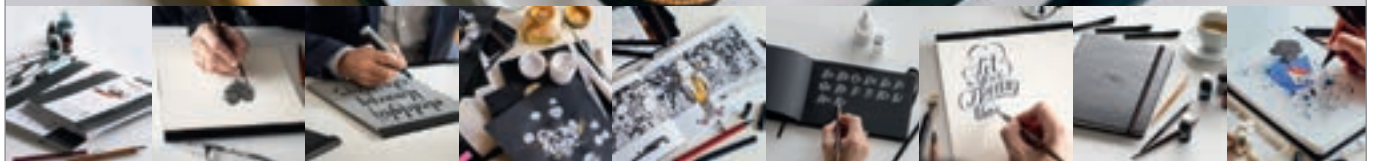

MARKER PAD

WHITE MAYA® PAD

GREY MAYA® PAD

BLACK MAYA® PAD

BRISTOL BOOK

CARBON® BOOK

CALLIGRAPHER PAD

CALLIGRAPHER BOOK

PEN & INKWASH BOOK

RHODIA
Touch

bloc-rhodia.com

À chaque art son papier, à chaque papier sa subtilité!

A collection of convenient notebooks and sketchpads designed especially for **calligraphers, urban sketchers, designers, architects and illustrators,** and for all paper connoisseurs.



c o l l e c t i o n
s c R i p t

*corps en aluminium brossé
portemine 0,5 mm
ou stylo à bille 0,7 mm*

*bois de rose
turquoise
orange
argent
sauge
rouge
noir
navy
or*

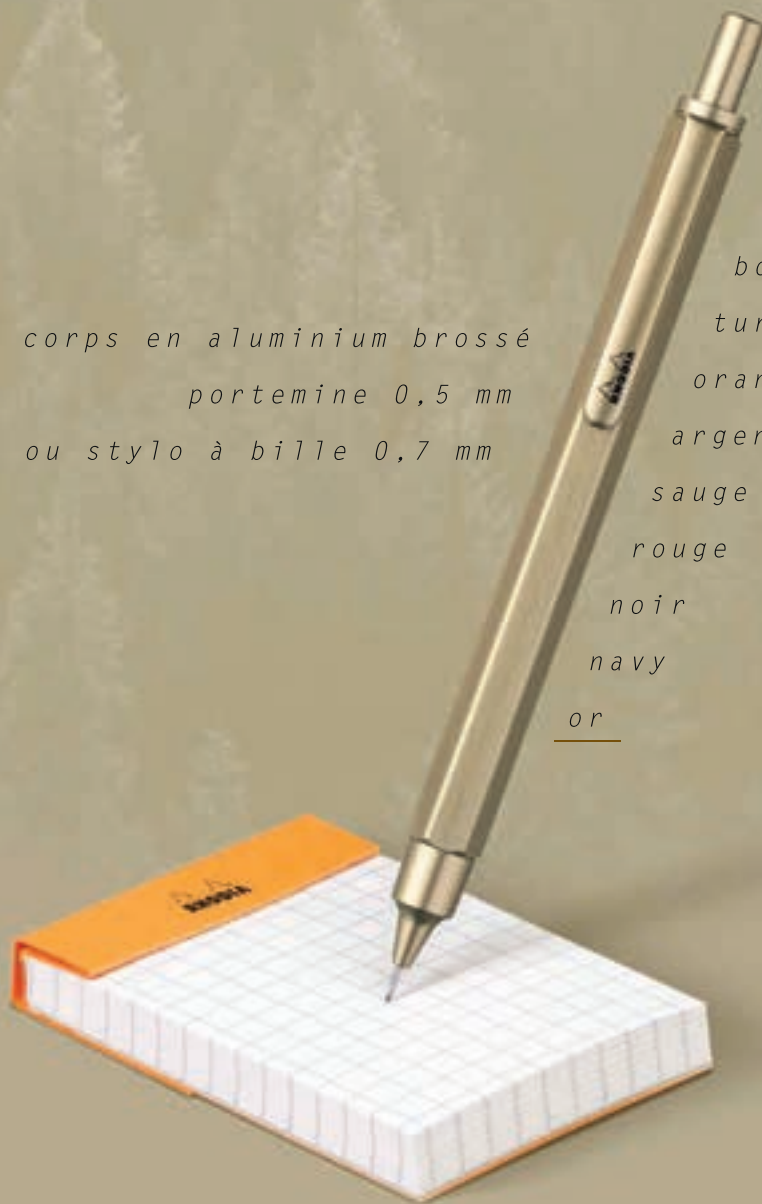

RHODIA

blocs, carnets, cahiers, agendas, instruments d'écriture et accessoires

b l o c - r h o d i a . c o m



Notes

A series of horizontal dotted lines for writing notes.



FRANCE

OTTMARSHEIM
RD 52
68490 Ottmarsheim
Tel. : 03 89 83 37 77
Fax : 03 89 83 37 78
EXPORT
Tel. : +33 3 89 83 37 83
Fax : +33 3 89 83 37 84

PARIS
Tel. : +33 1 40 40 44 46
Fax : +33 1 42 41 47 20

BRETAGNE
NORMANDIE
PAYS DE LA LOIRE
Tel. : +33 2 35 09 60 69
Fax : +33 2 35 90 55 28
chorcholle@clairefontaine.com

BORDEAUX
Tel. : +33 5 56 86 55 92
Fax : +33 5 56 86 70 78

SPAIN

BARCELONE
EXACLAI
Polígono Industrial Can Cuyàs
C/ Escultura, nave 18
08110 Montcada i Reixac
Tel. : +34 93 564 53 07
Fax : +34 93 564 59 14
exaclair@exaclair.es

NEW ZEALAND

FRESH OFFICE
72 Richard Pearse Drive,
Mangere, Auckland 2022
PO Box 78020, Grey Lynn,
Auckland 1245, New Zealand
www.freshoffice.co.nz

BENELUX

EXACLAI BENELUX
Paepsem Business Park
Boulevard Paepsem 18D
Paepsem 18D
B-1070 Anderlecht
Tel. : +32 2 468 21 60
Fax : +32 2 468 00 80
www.exaclair.eu
BELGIUM & LUXEMBURG
info.be@exaclair.eu
THE NETHERLANDS
info.nl@exaclair.eu

MOROCCO

CASABLANCA
PUBLIDAY MULTIDIA
4, Parc Industriel CFCIM
27182 BOUSKOURA
MOROCCO
Tel. : +212 522 59 24 28
Fax : +212 522 59 24 41
publiday@clairefontaine.com

GERMANY

COLOGNE
EXACLAI GmbH
Hansestraße 61/63
51149 Köln
Tel. : +49 2203 30430
Fax : +49 2203 304330
info@exaclair.de
www.exaclair.eu

CHILE

SANTIAGO
ILOP SA - LAPIZLOPEZ
Av. Américo Vespucio Norte 727
Huechuraba, Santiago
Tel. : +56 2 519 5000
Fax : +56 2 519 5088
www.lapizlopez.cl

ARTE PAPEL LTDA. - ARTE PAPEL
Las Urbinas 30
Providencia, Santiago
Tel. : +562 2932 3777
www.artepapel.cl
luis@artepapel.cl

RUSSIAN FEDERATION

MOSCOW
Smart Design Ltd.
Staroslobodskaya Str., 3
107113 Moscow
Tel. : / Fax +749 5287 4579
info@sdoffice.ru

UK & IRELAND

LONDRES
EXACLAI Ltd.
Oldmedow Road,
King's Lynn, Norfolk PE30 4LW
Tel. : +44 (0) 1553 696600
enquiries@exaclair.co.uk
www.exaclairlimited.com

ITALY

MILAN
EXACLAI
Via Soperga, 36
20127 Milano
Tel. : +39 02 285 108 90
Fax : +39 02 283 403 73
servizioclienti@exaclair.it

CANADA

MONTREAL
LAMARCHE IMPORTATION
5000, rue Eadie
Montréal / Québec H4E 4P2
Tel. : +1 514 762 6069
Fax : +1 514 762 6078
info@lamarche-import.com

UNITED STATES

NEW YORK
EXACLAI INC
143 West 29th Street Suite 1000
New York, NY 10001
Tel. : +1 646 473 1754
Fax : +1 646 473 1422
sales@exaclair.com
www.exaclair.com

JAPAN

TOKYO
QUO VADIS JAPAN CO., LTD.
1-4-15 Sanai Building 4F
Komazawa Setagaya-ku
Tokyo 154-0012
Tel. : +81 3 3411 7122
Fax : +81 3 3411 7123
info@quovadis.co.jp

INDONESIA

CV. ARTEMEDIA HIDAYAT INDONESIA
Jalan Soekarno Hatta No. 31
Bandung, West Java 40212
Tel. : +6222 4260688
cs@artemedia.id
www.artemedia.id

AUSTRALIA

SYDNEY
PAPERIE
13/170 Harbord Rd
Brookvale NSW 2100
Tel. : +61 4 1766 8898
info@thepaperie.com.au
www.thepaperie.com.au

SOUTH KOREA

GYEONGGI-DO
C.R.K.
Opo-eup
Gwangju-Si-Munheyong-Ri 133
Gyeonggi-Do 464894
Tel. : +82 317651706
Fax : +82 2224495212

PORTUGAL

LINDA-A-VELHA
STARBRANDS
Largo da Lagoa, 7C Sala 205B
2795-116 LINDA-A-VELHA
Tel. : +351 210 987 279
geral@starbrands.pt
www.starbrands.pt

DENMARK

POVL KLITGAARD & CO APS
Lauretsvej 21
2880 Bagsvaerd
Tel. : +45 4444 0885
service@p-klitgaard.dk
www.p-klitgaard.dk

SWEDEN

DESPEC SWEDEN AB
Pyramidbacken 6, S-141 75 Kungens
Kurva, Sweden
Tel. : +46 8 449 59 00
info@despec.se
www.despec.se

FINLAND

DESPEC FINLAND OY
Bertel Jungin aukio 7,
02600 Espoo, Finland
Tel. : +358 9 827 53 00
myynti@despec.fi
www.despec.fi

EGYPT

CAIRO
SAMIR & ALY
64 Zaker Hussein Street
12211 Nasr City, Cairo
Tel. : +20 22 62 73 33
Fax : +20 22 63 53 49
samiralyinfo@samir-aly.com
www.samirandy.com

SWITZERLAND

BIELLA SCHWEIZ AG
Erlenstrasse 44
CH-2555 Brügg
Tel. : +41 32 366 33 33
Fax : +41 32 366 32 10
info@biella.ch
www.biella.ch

MALAYSIA

KUALA LUMPUR
CZIPLEE (MALAYSIA) SDN BHD
3, Jalan Telawi 3
Bangsar Baru
59100 Kuala Lumpur
partners@cziplee.com
www.cziplee.com

ROMANIA

AUSTRAL TRADE SRL
Sos. Pipera-Tunari 1C, Voluntari, Ilfov.
sales@austral.ro
www.austral.ro
Tel. : +40 21 528 18 18
Fax : +40 21 528 18 16

HUNGARY

PATRIA NYOMDA ZRT
Hunyadi János út 7
1117 Budapest
Tel. : +36 1 463-0440
Fax : +36 1 463-0450
info@patria.hu
www.patria.hu
PIREX 98 KFT
Torbágy utca 18.
2045 Törökbálint
Tel. : +36 (23) 511600
Fax : +36 (23) 511601
www.pirex.hu
www.facebook.com/PirexPapir

SINGAPORE

OVERJOYED
THE CATHAY,
2 Handy road #B1-11,
SINGAPORE 229233
Tel. : +65 6466 4366
sales@overjoyed.com.sg

CHINA MAINLAND HONG KONG/MACAO

INK HOUSE
Shop C, G/F, World Trust Tower
50 Stanley street
Central Hong Kong
Tel. : +852 2537 8828

TAIWAN (ROC)

FINE WRITING INTERNATIONAL LTD
12F-1, No 335, Sec 3, Roosevelt Rd,
TAIPEI CITY 10647, TAIWAN
Tel. : +8862 2366 0260
lulee@finewriting.com.tw

TURKEY

ISTANBUL
ESMO BURO ARAÇLARI VE TERSİM
MALZEMELERİ TİCARET ANONİM ŞİRKETİ
PiyalePaşa Mahallesi AğaçKöprü Sokak
Kastel İş Merkezi C Blok Kat 7 Kasımpaşa
34440 Beyoğlu İstanbul Türkiye
Tel. : +90 212 3613595
Fax : +90 212 3614060 / 3613246
info@esmo.com.tr

C04 90009C



RHODIA

collection 2023

bloc-rhodia.com
CLAIREFONTAINE RHODIA SAS

